

CATALOG #67 2026

BANJO LIQUID HANDLING PRODUCTS

**BANJO**<sup>®</sup>  
Liquid Handling Products

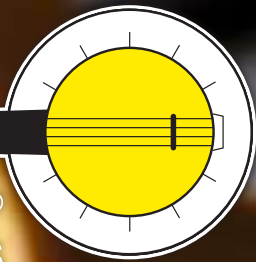

2026



BOOM 6

BOOM 5

BOOM 4

BOOM 3

BOOM 2

BOOM 1



# THE #ORIGINALYELLOWHANDLE



**BANJO CORPORATION**  
A Unit of IDEX Corporation  
150 Banjo Drive  
Crawfordsville, IN 47933 U.S.A.  
Telephone: (765) 362-7367  
Fax: (765) 362-0744  
banjocorp.com  
#OriginalYellowHandle



Follow us on:     

Scan to visit  
[BanjoCorp.com](http://BanjoCorp.com)

# INDEX

**NEW & RETURNING** 3-6

**VALVES** 8-19

**ELECTRIC VALVES** 20-24  
**KZVALVE** 25-33

**MANIFOLD FLANGE CONNECTIONS** 34-60

**DRY DISCONNECTS** 61-71

**IBC/TANK ACCESSORIES** 72-80

**CAM LEVER COUPLINGS** 81-85

**PIPE FITTINGS** 86-91

**LINE STRAINERS** 92-103

**CENTRIFUGAL PUMPS** 104-165

**REFERENCE** 166-180

# BECAUSE EVERY DROP COUNTS



95% **LESS**  
SPILLAGE,  
SAVING YOU  
MONEY

More information on our Dry Fit series is on page 70



## REPLACE HOSE RUNS WITH SOLID PIPE

### Advantages

- Fewer Components
- Better Flow Characteristics
- Easier to Install
- Improved Clean out & Cosmetics

One piece molded construction



### Applications

- Replace Hose Runs, Hose Barbs
- Nurse Wagons, Sprayers, Side-Dress Bars

#### OHIO PIPING

PART NO	DESCRIPTION	MAX PSI	LOT QTY
M300CPG27	3" MANIFOLD COUPLING X 27"	200	6
M300CPG32	3" MANIFOLD COUPLING X 32"	200	6
M300CPG38	3" MANIFOLD COUPLING X 38"	200	6



GX200 NOW STANDARD

### Transitioned from 5.5hp to 6.5hp Honda engines

- Higher HP Honda engine
- Same list price as 5.5 HP
- Lightweight & Portable
- Low Maintenance

#### HONDA DRIVEN PUMPS

PREVIOUS PART NO	NEW PART NUMBER
200PH-5BN	200PH6BN
200PH-5V	200PH6V
200PIH-5	200PIH6
200PIH5V	200PIH6V
200PH5-SS	200PH6SS
M220PH5W	M220PH6W
201PIH5W	201PIH6W

# KZVALVE NOW AVAILABLE THROUGH BANJO!

Whether you are plumbing a new system or replacing old parts, KZValve has solutions for your unique needs.

## NH3 ANHYDROUS AMMO BALL VALVES

- WATERPROOF SOLUTIONS
- US DESIGNED & BUILT
- LEADING TECHNOLOGY
- COMPETITIVE PRICING



## 95 SERIES 2-WAY PVC VALVE

- WATER SUPPLY SYSTEMS
- IRRIGATION SYSTEMS
- CHEMICAL PROCESSING
- SWIMMING POOLS
- AQUARIUMS & FISH TANKS

## ZIPVALVE SERIES

- VERY FAST
- PRECISION ACCURACY
- COMPETITIVE PRICING
- ROBUST WATERPROOF



CHECK OUT MORE **KZ** PRODUCTS NOW OFFERED THROUGH  
**BANJO** ON PAGE 25

# FEATURED PRODUCTS

## FITTINGS WITH GAUGE PORTS

PART NO	DESCRIPTION	MAX PSI	LOT QTY
M100BRBSWPG90	1" FULL PORT X 1" HOSE BARB WITH 1/4" GAUGE PORT	300	10/BAG
M100BRBSWPG90A	1" FULL PORT X 1" HOSE BARB WITH 1/4" GAUGE PORT	300	10/BAG
M100SWPG90	1" FLANGE X FLANGE SWEEP WITH 1/4" GAUGE PORT	300	10/BAG
M100TEE025G	1" FLANGED TEE WITH 1/4" GAUGE PORT	.300	10/BAG
M220SWP038G90	2" FULL PORT MANIFOLD SWEEP WITH 3/8" FNPT GAUGE PORT	300	10/BAG
M220SWP050G90	2" FULL PORT FLANGE X FLANGE SWEEP WITH 1/2" GAUGE PORT	300	10/BAG
M220SWPG90	2" FULL PORT FLANGEXFLANGE SWP 1/4"PORT	250	1
M221SWP90	2" FULL PORT MANIFOLD SWEEP WITH BLIND GAUGE PORT	300	1
M300BRBSWPG90	3" HOSE BARB X FLANGE SWEEP WITH 1/4" GAUGE PORT	225	1
M300SWP050G90	3" MANIFOLD SWEEP W/ .5" NPT PORT	300	1
M300SWPG90	3" FLANGE X FLANGE SWEEP WITH 1/4" GAUGE PORT	200	1
M200300TEG075	M200 X M200 X M300 WITH 3/4" THREAD PORT	300	1
M200YG45	2" FULL PORT 45° Y FLANGE WITH GAUGE PORT	225	1
M220YG45	2" FULL PORT 45° Y FLANGE WITH 3/4" GAUGE PORT	300	1
M300YG45	3" FULL PORT Y FLANGE WITH 3/4" GAUGE PORT	200	1
M300220WYCG	M300 X M220 Y CROSS WITH 1/4" GAUGE PORT	300	1
TEG075	3/4" POLY T WITH 1/4" FEMALE THREAD	300	10/BAG
TEG100	1" POLY TEE WITH 1/4" FEMALE THREAD	300	10/BAG
TM075/050	8 STATION POLY MANIFOLD	225	1



## COUPLINGS WITH GAUGE PORTS

PART NO	DESCRIPTION	MAX PSI	LOT QTY
M100CPG025G	1" MANIFOLD COUPLING 2 1/4" PORT	300	10/BAG
M101CPG	1"MANIFOLD COUPLING 2 1/2" LONG W/ BLIND GAUGE PORT	300	10/BAG
M200CPG025G	2" MANIFOLD COUPLING 4 1/2" LONG W/ 1/4" PORT	300	10/BAG
M200CPG038G	2" MANIFOLD COUPLING 4 1/2" LONG W/ 3/8" PORT	300	10/BAG
M201CPG	2" MANIFOLD COUPLING 4 1/2" LONG W/ BLIND GAUGE PORT	300	10/BAG
M220CPG2GISO	2" FULL PORT MANIFOLD COUPLING 2" LONG W/ G1/4" PORT	300	10/BAG
M220CPG3G	2" FULL PORT MANIFOLD COUPLING 3" LONG W/ 1/2" PORTS (3)	225	10/BAG
M220CPG3G1	2" FULL PORT MANIFOLD COUPLING 2" LONG W/ 1/2" PORTS (3)	225	10/BAG
M220CPG6025G	2" FULL PORT MANIFOLD COUPLING 6" LONG W/ 1/4" PORTS	300	10/BAG
M221CPG	2" FP MANIFOLD COUPLING 3" LONG W/ 3 BLIND GAUGE PORTS	300	1
M221CPG6	2" FP MANIFOLD COUPLING 6" LONG W/ BLIND GAUGE PORT	300	10/BAG
M300CPG12G	3" FP MANIFOLD COUPLING 12" LONG W/ 1/2" GAUGE PORT	150	1
M300CPG2	3" FP MANIFOLD COUPLING 4" LONG W/ BLIND GAUGE PORT	200	1
M300CPG3G1	3" FP MANIFOLD COUPLING 3" LONG W/ BLIND GAUGE PORT	200	1
M300CPG55G	3" FULL PORT MANIFOLD COUPLING 5.5" LONG W/ 1/4" PORT	150	1
M300CPG7025G	3" MANIFOLD COUPLING 7 " LONG W/ 1/4" PORT	300	1
M301CPG7	3" MANIFOLD COUPLING 7" LONG	150	1
M300CPG2GISO	3" MANIFOLD COUPLING 2" LONG W/ G1/4" GAUGE PORT	300	1



## PLUGS WITH GAUGE PORTS

PART NO	DESCRIPTION	MAX PSI	LOT QTY
M100PLG025	1" FLANGE PLUG WITH 1/4" FEMALE NPT	300	10/BAG
M100PLG050	1" FLANGE PLUG WITH 1/2" FEMALE NPT	300	10/BAG
M200PLG025	2" FLANGE PLUG WITH 1/4" FPT	225	10/BAG
M200PLG038	2" MANIFOLD PLUG WITH 3/8" FPT	300	10/BAG
M200PLG050	2" FLANGE PLUG WITH 1/2" FPT	225	10/BAG
M200PLG075	2" FLANGE PLUG WITH 3/4" FPT	225	10/BAG
M200PLG100	2" FLANGE PLUG WITH 1" FPT	225	10/BAG
M220PLG038	2" FP MNFLD PLUG WITH 3/8" FPT	150	10/BAG
M220PLG075	2" FP FLANGE PLUG WITH 3/4" FPT	225	10/BAG
M300PLG075	3" FLANGE PLUG WITH 3/4" FPT	200	1
M300PLG100	3" FLANGE PLUG WITH 1" FPT	200	1



**M35** 

**500+ GALLONS PER MINUTE**  
**NO LEAKS. NO WEAR. NO WORRIES**  
**PATENTED WET SEAL DESIGN**  
**ATTACHES EASILY**

More information on our M350 series is on page 122



# VALVES

## EASY-FILL™ VALVES

### FEATURES

- Eliminates multiple fittings for fill applications
- Available in 2" and 3" sizes
- Full flow (full port) design
- Stubby valve configuration reduces profile
- Extended coupler prevents handle interference



### EASY-FILL™ VALVES

PART NO	DESCRIPTION	MAX PSI	LOT QTY	VALVE HANDLE	REPAIR KIT
VSBHB204FP	2" FULL PORT EASY-FILL™ VALVE	150	2/BOX	VS25153	VS25200
VSBHB205FP	2" FULL PORT EASY-FILL™ VALVE W/CARRY HANDLE	150	4/BOX	VS25153	VS25200
VSBHB304FP	3" FULL PORT EASY-FILL™ VALVE	150	2/BOX	V25153	VS35200EF
VSBHB305FP	3" FULL PORT EASY-FILL™ VALVE W/CARRY HANDLE	150	4/BOX	V25153	VS35200EF
H25053	2" & 3" CARRY HANDLE	N/A	1	N/A	N/A

## 1/4" - 1" POLY MICRO VALVES

### FEATURES

- 90° rotating handle
- 90° locking, rotating handle (with asterisk \*)
- Precision molded polypropylene is reinforced with fiberglass for additional strength.
- Standard FKM seats and O-Rings

 **John Guest** Fitting

The brand **John Guest** is a registered trademark of John Guest International Limited.

### MICRO VALVES

PART NO	DESCRIPTION	MAX PSI	THREAD SIZE	OPENING THRU BALL	LOT QTY
LV025V	1/4" FEMALE NPT MICRO VALVE	300	1/4"	3/8"	10
LV038V	3/8" FEMALE NPT MICRO VALVE	300	3/8"	3/8"	10
LV050V	1/2" FEMALE NPT MICRO VALVE	300	1/2"	15/32"	10
LV050SLV	1/2" SIDE LOAD MICRO VALVE	300	1/2"	15/32"	10
LV050SLLV*	1/2" SIDE LOAD LOCKING MICRO VALVE	300	1/2"	15/32"	10

### MICRO VALVES

PART NO	DESCRIPTION	MAX PSI	THREAD SIZE	OPENING THRU	LOT QTY
LVHB038V	3/8" HOSE BARB MICRO VALVE	300	3/8"	3/8"	10
LVHB050V	1/2" HOSE BARB MICRO VALVE	300	1/2"	3/8"	10
LVHB075V	3/4" HOSE BARB MICRO VALVE	300	3/4"	15/32"	10

### MICRO VALVES

PART NO	DESCRIPTION	MAX PSI	THREAD SIZE	OPENING THRU BALL	LOT QTY
LV025MTV	1/4" FEMALE X MALE NPT MICRO VALVE	300	1/4"	3/8"	10
LV038MTV	3/8" FEMALE X MALE NPT MICRO VALVE	300	3/8"	3/8"	10
LV038050MTV	3/8" FEMALE X 1/2" MALE NPT MICRO VALVE	300	3/8" x 1/2"	3/8"	10
LV038050MTLV*	3/8" FEMALE X 1/2" MALE NPT LOCKING MICRO VALVE	300	3/8" x 1/2"	3/8"	10
LV050MTV	1/2" FEMALE X MALE NPT MICRO VALVE	300	1/2"	15/32"	10
LV050100MTV	1/2" FEMALE X 1" MALE NPT MICRO VALVE	300	1/2"	15/32"	10
LV050100MTLV*	1/2" FEMALE X 1" MALE NPT LOCKING MICRO VALVE	300	1/2" x 1"	15/32"	10

### MICRO VALVES

PART NO	DESCRIPTION	MAX PSI	THREAD SIZE	OPENING THRU BALL	LOT QTY
LVHB038050MTV	3/8" HOSE BARB X 1/2" MALE NPT MICRO VALVE	300	1/2"	3/8"	10
LVHB075MTV	3/4" HOSE BARB X 3/4" MALE NPT MICRO VALVE	300	3/4"	15/32"	10
LVHB075100MTV	3/4" HOSE BARB X 1" MALE NPT MICRO VALVE	300	1"	15/32"	10
LVHB075100MTLV	3/4" HOSE BARB X 1" MALE NPT LOCKING MICRO VALVE	300	1"	15/32"	10
LVHB075050MTLV	3/4" HOSE BARB X 1/2" MALE NPT LOCKING MICRO VALVE	300	1/2"	15/32"	10

### MICRO VALVES

PART NO	DESCRIPTION	MAX PSI	THREAD SIZE	OPENING THRU BALL	LOT QTY
LVPL025V	1/4" FEMALE PUSH LOCK MICRO VALVE	300	1/4"	3/8"	10
LVPL038V	3/8" FEMALE PUSH LOCK MICRO VALVE	150	3/8"	3/8"	10

# VALVES

## 1/2" - 2" 4 BOLTED VALVES

### FEATURES

- FKM seals.
- Precision molded polypropylene is reinforced with fiberglass for additional strength.
- Self-aligning ball moves freely against the PTFE seats for smooth operation. The valve opens and closes with very little pressure on the handle.
- Ball is diamond turned, after molding, to make it spherically perfect, which provides precise contact between ball and seats.
- PTFE self-lubricating stem bushings and seats cannot stick or bind.
- Stainless steel bolts.

### REPAIR KIT INCLUDES:

- Ball
- Body gasket
- Thrust washer
- Ball seats
- Upper stem bushing
- Stem o-ring



### 4 BOLTED VALVES

PART NO	DESCRIPTION	MAX PSI	PIPE SIZE	OPENING THRU	LOT QTY	REPLACEMENT HANDLE	REPAIR KIT
V050	1/2" FULL PORT VALVE	300	1/2"	3/4"	6	V10153A	N/A
V075	3/4" FULL PORT VALVE	300	3/4"	3/4"	12	V10153A	N/A
V100	1" STANDARD PORT VALVE	225	1"	3/4"	12	V10153A	N/A
V100FP	1" FULL PORT VALVE	300	1"	1"	12	V10153A	V10200
V125	1 1/4" STANDARD PORT VALVE	300	1 1/4"	1"	6	V10153A	V10200
V125FP	1 1/4" FULL PORT VALVE	225	1 1/4"	1 1/2"	6	V20153	V20200
V150	1 1/2" FULL PORT VALVE	225	1 1/2"	1 1/2"	6	V20153	V20200
V200	2" STANDARD PORT VALVE	225	2"	1 1/2"	12	V20153	V20200

## 2" FULL PORT 4 BOLTED BALL VALVES

### FEATURES

- FKM seals
- Stainless steel bolts
- PTFE self-lubricating stem bushings and seats cannot stick or bind
- Precision molded in fiberglass reinforced polypropylene
- Self-aligning ball moves freely against the PTFE seats for smoother operation
- Valve opens and closes with very little pressure on the handle
- Ball is diamond turned after molding to make it spherically perfect, which provides precise contact between ball and seats



### 4 BOLTED FULL PORT VALVES

PART NO	DESCRIPTION	MAX PSI	PIPE SIZE	OPENING THRU BALL	LOT QTY	REPLACEMENT HANDLE	REPAIR KIT
VFMT204FP	2" FULL PORT VALVE MALE NPT X MALE ADAPTER	150	2"	2"	6/BOX	V25153	V25200
V204FP	2" FULL PORT VALVE	150	2"	2"	8/BOX	V25153	V25200

## 2"-4" 6 BOLTED VALVES



### FEATURES

- FKM seals.
- Precision molded polypropylene is reinforced with fiberglass for additional strength.
- Self-aligning ball moves freely against the PTFE seats for smooth operation. The valve opens and closes with very little pressure on the handle.
- Ball is diamond turned, after molding, to make it spherically perfect, which provides precise contact between ball and seats.
- PTFE self-lubricating stem bushings and seats cannot stick or bind.
- Stainless steel bolts.

### REPAIR KIT INCLUDES:

- Ball
- Body gasket
- Thrust washer
- Ball seats
- Upper stem bushing
- Stem o-ring

### 6 BOLTED VALVES

PART NO	DESCRIPTION	MAX PSI	PIPE SIZE	OPENING THRU BALL	LOT QTY	REPLACEMENT HANDLE	REPAIR KIT
V200FP	2" FULL PORT VALVE	225	2"	2"	8/BOX	V25153	V25200
VFMT200FP	2" FULL PORT VALVE W/ F ADAPTER	225	2"	2"	6/BOX	V25153	V25200
V300	3" STANDARD PORT VALVE	225	3"	2½"	8/BOX	V25153	V30200
V300FP	3" FULL PORT VALVE	200	3"	3"	6/BOX	V25153	V35200
V400	4" STANDARD PORT VALVE	100	4"	3½"	1	V25153	V40200

## 2" FULL PORT ANSI FLANGE BOLTED BALL VALVES



VSF200FPAF

### FEATURES

- 100% PTFE seats
- FKM seals
- Glass-filled polypropylene
- Unique compact design
- Lightweight
- Gaskets featured on page 74

### REPAIR KIT INCLUDES:

- Ball
- Body gasket
- Thrust washer
- Ball seats
- Upper stem bushing
- Stem o-ring

### FULL PORT ANSI FLANGE BOLTED VALVES

PART NO	DESCRIPTION	MAX PSI	PIPE SIZE	OPENING THRU BALL	LOT QTY	REPLACEMENT HANDLE	REPAIR KIT
VSF200FPAF	2" FULL PORT VALVE MALE ADAPTER X 2" ANSI FLANGE	200	2"	2"	6/BOX	V25153SH	VS25200

# VALVES

## VALVE ACCESSORIES

### FEATURES

- 304 stainless steel construction
- Installs under valve handle
- Comes complete with handle and locking device
- Padlock not included



### VALVE ACCESSORIES

PART NO	DESCRIPTION	FITS VALVES	LOT QTY
V10200	VALVE REPAIR KIT 1" FP & 1/4"	V100FP, V125M MV100CF	1
V10270	STRAIGHT MOUNTING BRACKET	V100FP, V125	1
V10271	90° MOUNTING BRACKET	V100FP, V125	1
VL20153	LOCKING DEVICE	V125, V150, V200	1
V25270	STRAIGHT MOUNTING BRACKET	V125FP, V150, V200	1
V25271	90° MOUNTING BRACKET	V125FP, V150, V200	1
V10153138	1" X 1 3/8" HANDLE OFFSET	V100FP, V125	1
V20153138	2" X 1 3/8" HANDLE OFFSET	V125FP, V150, V200	10
V25153138	2" FP X 1 3/8" HANDLE OFFSET	V200FP	1
V10153138BL	1" X 1 3/8" BL HANDLE OFFSET	V100BL, MV100BL	1
V20153138BL	2" X 1 3/8" BL HANDLE OFFSET	V125BL, V150BL, MV200BL	10
V25153138BL	2" FP X 1 3/8" BL HANDLE OFFSET	V200BL, MV220BL	1

## VALVE ACCESSORIES

### FEATURES

- Stainless steel hardware
- Locks in open and closed positions
- Locking handle replaces standard handle (sold separately)
- Padlock not included



V25270

V25271

### VALVE ACCESSORIES

PART NO	DESCRIPTION	FITS VALVES	QTY
VL25153	LOCKING HANDLE	V200FP, V300, V300FP, V400, VFMT200FP	1
V25270	STRAIGHT MOUNTING BRACKET	V200FP, V300, V300FP, V400, VFMT200FP	1
V25271	90° MOUNTING BRACKET	V200FP, V300, V300FP, V400, VFMT200FP	1

## 2" STANDARD PORT STUBBY BALL VALVES



VSF200



VSMT200



VSFMT200



VSFHB200

### FEATURES

- Stainless steel bolts
- Glass reinforced polypropylene
- Multiple design options
- Unique patented compact design
- Lightweight
- All PTFE seals

### 2" STANDARD PORT STUBBY VALVES

PART NO	DESCRIPTION	MAX PSI	PIPE SIZE	OPENING THRU BALL	LOT QTY	REPLACEMENT HANDLE	REPAIR KIT
VSF200	2" MALE ADAPTER X 2" FEMALE NPT	100	2"	1½"	6	VS20152SH	VS20200
VSMT200	2" MALE NPT X 2" FEMALE NPT	100	2"	1½"	6	VS20152SH	VS20200
VSFMT200	2" MALE ADAPTER X 2" MALE NPT	225	2"	1½"	12	VS20152SH	VS20200
VSFHB200	2" MALE ADAPTER X 2" HOSE BARB	100	2"	1½"	6	VS20152SH	VS20200

## 2" FP STUBBY STAINLESS STEEL VALVE



VSFMT220SS

### FEATURES

- PTFE seals, no elastomers
- Self-aligning ball moves freely against the PTFE seats for smooth operation. The valve opens and closes with very little pressure on the handle
- PTFE self-lubricating stem bushings and seats cannot stick or bind

### 2" FULL PORT STUBBY STAINLESS STEEL VALVE

PART NO	DESCRIPTION	MAX PSI	PIPE SIZE	OPENING THRU BALL	QTY	REPLACEMENT HANDLE	REPAIR KIT
VSFMT220SS	2" FULL PORT STUBBY SS VALVE MALE THREAD X MALE ADAPTER	225	2"	2"	1	VSS20153	VSS25200

# VALVES

## 2" FULL PORT STUBBY BALL VALVES

### FEATURES

- Stainless steel bolts
- 100% PTFE ball seats
- Glass reinforced polypropylene
- Unique patented compact design
- Lightweight
- FKM body seals

### REPAIR KIT INCLUDES:

- Ball
- Body gasket
- Thrust washer
- Ball seats
- Upper stem bushing
- Stem o-ring



VSMT204FP



VSF204FP



VS204FP



VSFMT204FP



VSFMT204HSFP

### 2" FULL PORT STUBBY VALVES

PART NO	DESCRIPTION	MAX PSI	PIPE SIZE	OPENING THRU BALL	LOT QTY	REPLACEMENT HANDLE	REPAIR KIT
VSMT204FP	2" MALE NPT X 2" FEMALE NPT	200	2"	2"	6	VS25153	VS25200
VSF204FP	2" MALE ADAPTER X 2" FEMALE NPT	100	2"	2"	6	VS25153	VS25200
VS204FP	2" FEMALE NPT X 2" FEMALE NPT	225	2"	2"	6	VS25153	VS25200
VSFMT204FP	2" MALE ADAPTER X 2" MALE NPT	150	2"	2"	6	VS25153	VS25200
VSFMT204HSFP	2" FP MALE ADAPTER X 2" MALE NPT W/ SS BALL, STEM & HANDLE	150	2"	2"	6	N/A	VSSH25200



### 3" STANDARD PORT STUBBY BALL VALVES

#### FEATURES

- Stainless steel bolts
- Glass reinforced polypropylene
- FKM body seals
- Unique patented compact design
- Lightweight
- All PTFE seats
- Note: If repair kits not listed, components available.

#### 3" STANDARD PORT STUBBY VALVES

PART NO	DESCRIPTION	MAX PSI	PIPE SIZE	OPENING THRU BALL	LOT QTY	REPLACEMENT HANDLE STRAIGHT	REPLACEMENT HANDLE SHORT	REPAIR KIT
VSF300	3" FEMALE NPT X 3" MALE ADAPTER	100	3"	2½"	6/BOX	V25153	V25153SH	VS30200
VSMT300	3" FEMALE NPT X 3" MALE NPT	100	3"	2½"	6/BOX	V25153	V25153SH	VS30200
VSFMT300	3" MALE NPT X 3" MALE ADAPTER	225	3"	2½"	6/BOX	V25153	V25153SH	VS30200



### 3" FULL PORT STUBBY BALL VALVES

#### FEATURES

- Stainless steel bolts
- Glass reinforced polypropylene
- FKM body seals
- Unique patented compact design
- Lightweight
- All PTFE ball seats
- Note: If repair kits not listed, components available.

#### 3" FULL PORT STUBBY VALVES

PART NO	DESCRIPTION	MAX PSI	PIPE SIZE	OPENING THRU BALL	LOT QTY	REPLACEMENT HANDLE	REPAIR KIT
VSFMT300FP	3" FULL PORT MALE ADAPTER X 3" MALE NPT	100	3"	3"	6/BOX	V25153	VS35200
VSFMT300HSFP	3" FULL PORT MALE ADAPTER X 3" MALE NPT W/SS BALL, STEM & HANDLE	100	3"	3"	6/BOX	VS30153SS	N/A

# VALVES

## 3 WAY BOTTOM LOAD BALL VALVES

### FEATURES

- Stainless steel bolts
- Precision molded in fiberglass reinforced polypropylene for additional strength
- Self-aligning ball moves freely against the PTFE seats for smooth operation
- Ball is diamond turned after molding to make it spherically perfect, which provides precise contact between ball and seats
- PTFE self-lubricating stem bushings and seats
- FKM body seals
- Directional flow, right or left. Valve can be turned off to stop flow



### 3 WAY BOTTOM LOAD VALVES

PART NO	DESCRIPTION	MAX PSI	PIPE SIZE	OPENING THRU BALL	LOT QTY	HANDLE TYPE	REPLACEMENT HANDLE	REPAIR KIT
V075BL	¾" 3-WAY BOTTOM LOAD VALVE	200	¾"	1"	6	T	V10353TB	N/A
V100BL	1" FP 3-WAY BOTTOM LOAD VALVE	225	1"	1"	6	T	V10353TB	N/A
V125BL	1¼" 3-WAY BOTTOM LOAD VALVE	300	1¼"	1½"	6	T	V20353TB	V15200BL
V150BL	1½" FP 3-WAY BOTTOM LOAD VALVE	225	1½"	1½"	6	T	V20353TB	V15200BL
V200BL	2" FP 3-WAY BOTTOM LOAD VALVE	200	2"	2"	8/BOX	STRAIGHT	V25353B	V25200BL

## 3 WAY SIDE LOAD BALL VALVES

### FEATURES

- Stainless steel bolts
- Precision molded in fiberglass reinforced polypropylene for additional strength
- Self-aligning ball moves freely against the PTFE seats for smooth operation
- Ball is diamond turned after molding to make it spherically perfect, which provides precise contact between ball and seats
- PTFE self-lubricating stem bushings and seats
- FKM body seals
- Directional flow, right or left. Valve cannot be turned off to stop flow



### 3 WAY SIDE LOAD VALVES

PART NO	DESCRIPTION	MAX PSI	PIPE SIZE	OPENING THRU BALL	LOT QTY	HANDLE TYPE	REPLACEMENT HANDLE	REPAIR KIT
V075SL	¾" 3-WAY SIDE LOAD VALVE	200	¾"	1"	6	STRAIGHT	V10153A	N/A
V100SL	1" FP 3-WAY SIDE LOAD VALVE	200	1"	1"	6	STRAIGHT	V10153A	N/A
V125SL	1¼" 3-WAY SIDE LOAD VALVE	300	1¼"	1½"	6	T	V20353TS	V15200BL
V150SL	1½" FP 3-WAY SIDE LOAD VALVE	225	1½"	1½"	6	T	V20353TS	V15200BL
V200SL	2" FP 3-WAY SIDE LOAD VALVE	225	2"	2"	8/BOX	STRAIGHT	V25153SH	V25200BL

## 1½" - 2" NOZZLE VALVES

### FEATURES

- Lightweight hose end valve for convenient transfer of liquids into drums, tanks etc
- Angled end flange with 8" long polypropylene fill spout
- All stainless steel bolts



VA150



VA200FP

### 1½"-2" NOZZLE VALVES

PART NO	DESCRIPTION	MAX PSI	PIPE SIZE	OPENING THRU BALL	FEMALE NPT	LOT QTY	REPLACEMENT HANDLE	REPLACEMENT NOZZLE	REPAIR KIT
VA150	1½" NOZZLE VALVE WITH 90° ELBOW	225	1½" x 8"	1½"	1½"	6	V20152	V20166	V20200
VA200	2" NOZZLE VALVE WITH 90° ELBOW	200	2" x 8"	1½"	2"	6	V20152	V25156	V20200
VA200/150	2" FEMALE NPT X 1½" NOZZLE	200		1½"	1½"	1	V20152	V25156	V20200
VA200FP	2" FP NOZZLE VALVE WITH 90° ELBOW	225	2" x 8"	2"	2"	6/BOX	V25152	V25156	V25200

## 1" DISPENSING NOZZLES

### FEATURES

- Glass reinforced polypropylene
- 304 stainless steel handle, spring and pin
- FKM rubber parts only
- Resists corrosion



VN100



V10161

### 1" DISPENSING NOZZLE

PART NO	DESCRIPTION	MAX PSI	PIPE SIZE	QTY	REPAIR KIT
VN100	1" DISPENSING NOZZLE	150	1"	1	VN10200
V10161	1" NOZZLE PIPE FOR USE WITH V100, V100FP, UV100FP, SUV100FP	150	1"	1	N/A

# VALVES

## 1/2" - 2" SINGLE UNION SPINWELD VALVES

### FEATURES

- Precision molded in glass reinforced polypropylene for strength and chemical resistance
- PTFE seats for smooth and proper sealing characteristics
- EPDM O-rings to handle most fertilizers and many chemicals
- Double O-rings in stem area for extra sealing protection
- Interlocking body and end plate to allow easy thread connection when installing valves
- Replacement parts not available



SUV125FP



MSUV100FP

### 1/2"-2" SINGLE UNION SPINWELD VALVES

PART NO	DESCRIPTION	MAX PSI	PIPE SIZE	OPENING THRU BALL	LOT QTY
SUV050FP	1/2" FULL PORT SINGLE UNION SPINWELD VALVE	300	1/2"	1/2"	10
SUV075FP	3/4" FULL PORT SINGLE UNION SPINWELD VALVE	300	3/4"	3/4"	10
SUV100FP	1" FULL PORT SINGLE UNION SPINWELD VALVE	300	1"	1"	10
SUV125FP	1 1/4" FULL PORT SINGLE UNION SPINWELD VALVE	300	1 1/4"	1 1/4"	10
SUV150FP	1 1/2" FULL PORT SINGLE UNION SPINWELD VALVE	300	1 1/2"	1 1/2"	10
SUV200FP	2" FULL PORT SINGLE UNION SPINWELD VALVE	200	2"	2"	10
MSUV100FP	1" MANIFOLD FULL PORT SINGLE UNION SPINWELD VALVE	300	1"	1"	10

## 1/2" - 2" SINGLE UNION VALVES

### FEATURES

- Precision molded in glass reinforced polypropylene for strength and chemical resistance
- PTFE seats for smooth and proper sealing characteristics
- Double O-rings in stem area for extra sealing protection
- Interlocking body and end plate to allow easy thread connection when installing valves
- Replacement parts not available



### 1/2"-2" SINGLE UNION VALVES

PART NO	DESCRIPTION	MAX PSI	PIPE SIZE	OPENING THRU BALL	LOT QTY
UV050FP	1/2" FULL PORT SINGLE UNION VALVE	300	1/2"	3/4"	10
UV075FP	3/4" FULL PORT SINGLE UNION VALVE	300	3/4"	3/4"	10
UV100FP	1" FULL PORT SINGLE UNION VALVE	300	1"	1"	10
UV125FP	1 1/4" FULL PORT SINGLE UNION VALVE	225	1 1/4"	1 1/4"	10
UV150FP	1 1/2" FULL PORT SINGLE UNION VALVE	200	1 1/2"	1 1/2"	10
UV200FP	2" FULL PORT SINGLE UNION VALVE	300	2"	2"	10

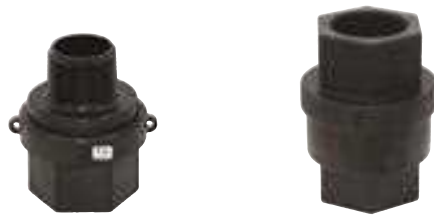

### 1/2"-3" CHECK VALVES

PART NO	DESCRIPTION	CRACKING PRESSURE PSI	MAX PSI	PIPE SIZE	LOT QTY
CV050	1/2" CHECK VALVE	6-7	300	1/2"	10
CV100	1" CHECK VALVE	1	300	1"	10
CV100MT	1" MALE X FEMALE NPT CHECK VALVE	1	300	1"	10
CV100V	1" FEMALE X FEMALE NPT CHECK	1	300	1"	1
CV221	2" FULL PORT CHECK VALVE	>0.5	300	2"	10
CV300	3" FULL PORT CHECK VALVE	1.5	300	3"	1
CV301	3" FULL PORT CHECK VALVE	>0.5	300	3"	1



### 1/4"-3" STAINLESS STEEL FULL PORT VALVES

PART NO	DESCRIPTION	MAX PSI	PIPE SIZE	OPENING THRU BALL	QTY	REPAIR KIT	REPLACEMENT HANDLE
VSS025	1/4" SS FULL PORT VALVE	1000	1/4"	1/4"	1	VSS02500	VSS05153
VSS038	3/8" SS FULL PORT VALVE	1000	3/8"	3/8"	1	VSS02500	VSS05153
VSS050	1/2" SS FULL PORT VALVE	1000	1/2"	1/2"	1	VSS05200	VSS05153
VSS075	3/4" SS FULL PORT VALVE	1000	3/4"	3/4"	1	VSS07200	VSS07153
VSS100	1" SS FULL PORT VALVE	1000	1"	1"	1	VSS10200	VSS10153
VSS150	1 1/2" SS FULL PORT VALVE	1000	1 1/2"	1 1/2"	1	VSS15200	N/A
VSS200	2" SS FULL PORT VALVE	1000	2"	2"	1	VSS25200	VSS20153
VSS300	3" SS FULL PORT VALVE	1000	3"	3"	1	VSS35200	N/A



### 3/4"-1" PINCH VALVES

PART NO	DESCRIPTION	GASKET	MAX PSI	PIPE SIZE	PRESSURE DIFFERENTIAL	LOT QTY
PV075	3/4" X 3/4" PINCH VALVE	EPDM	300	3/4"	15 TO 20 PSI	10
PV100	1" X 1" PINCH VALVE	EPDM	300	1"	15 TO 20 PSI	1
PV100-075	1" X 3/4" PINCH VALVE	EPDM	300	1" X 3/4"	15 TO 20 PSI	10
PV100-075V	1" X 3/4" PINCH VALVE	FKM	300	1" X 3/4"	15 TO 20 PSI	1
PV10265	BLADDER FOR PINCH VALVE	EPDM	N/A	N/A	N/A	1
PV10265V	BLADDER FOR PINCH VALVE	FKM	N/A	N/A	N/A	1

## 1/2" - 3" CHECK VALVES

### FEATURES

- One piece construction
- Glass reinforced polypropylene
- 316 stainless steel springs
- EPDM gasket

## 1/4" - 3" STAINLESS STEEL FULL PORT VALVES

- 316 stainless steel
- Blow out proof stem
- All valves 100% tested by air, under water at 100 PSI in open and closed positions
- Latch locking handle performs in both open and closed positions
- Mounting pad
- PTFE seals and seats

## 3/4" - 1" PINCH VALVES

- Open position allows full unobstructed flow of 50-60 GPM
- Air pressure collapses the internal rubber sleeve to provide positive shut off
- Standard EPDM rubber bladder seal and FKM available
- Female NPT threads
- ATTENTION: Normally an open valve and has a maximum liquid pressure of 70 PSI. Pressure differential = pressure it takes to close valve

# ELECTRIC VALVES



## SMALLER

- EVX 2" full port and 3" models are over 35% smaller than the average competitive valve. The 1½", 2" full port and 3" models are also substantially lighter than the average competitive valve.

## SMARTER

- EVX offers many protocol options for your needs:
  - On/Off
  - Regulating
  - Regulating with linear feedback
  - CAN/ISO BUS
  - Proportional control
- Diagnostic options for CANBUS
  - Voltage
  - Temperature
  - Cycle Count

## TOUGHER

- Setting the new standard for electric valve toughness, EVX passes 52 separate durability torture tests including mechanical shock, vibration, extreme temperature, rain/shine, operating pressure, and rigorous longevity tests.



**SMALLER / SMARTER / TOUGHER**

## 3/4" - 1 1/2" EVX SERIES



### FEATURES

- 12-volt DC operated
- 24-volt available
- Open/closed indicator
- 3/4"-1 1/4" ON/OFF has 3/4 sec response
- 1 1/2" ON/OFF has 1 1/2 sec response
- Regulating has 4 sec response
- Open/Close verification wires available
- IP68 waterproof
- -0 to 150F (-18 to 65C) operating
- -67 to 221F (-55 to 105C) storage
- On/Off Actuator rated to 500,000 cycles
- Regulating Actuator rated to 250,000 cycles
- Valve rated to 50,000 cycles leak-free
- Bolted valves have the same exact dimensions as our legacy EV valves.
- Additional protocols available including CAN/ISO BUS

### 3/4" - 1 1/2" EVX ON/OFF BOLTED ELECTRIC VALVES

PART NO	DESCRIPTION	MAX PSI	PIPE SIZE	OPENING THRU BALL	QTY	OPTIONAL HANDLE KIT	REPAIR KIT
EVX071	3/4" FULL PORT ELECTRIC VALVE	300	3/4"	1"	1	VP20153SH	EVX10200
EVX101	1" FULL PORT ELECTRIC VALVE	300	1"	1"	1	VP20153SH	EVX10200
EVX121	1 1/4" STANDARD PORT ELECTRIC VALVE	300	1 1/4"	1"	1	VP20153SH	EVX10200
EVX151	1 1/2" FULL PORT ELECTRIC VALVE	250	1 1/2"	1 1/2"	1	VP20153SH	EVX20200

### 3/4" - 1 1/2" EVX REGULATING BOLTED ELECTRIC VALVES

PART NO	DESCRIPTION	MAX PSI	PIPE SIZE	OPENING THRU BALL	QTY	OPTIONAL HANDLE KIT	REPAIR KIT
EVXR071	3/4" FULL PORT ELECTRIC VALVE	300	3/4"	1"	1	VP20153SH	EVX10200
EVXR101	1" FULL PORT ELECTRIC VALVE	300	1"	1"	1	VP20153SH	EVX10200
EVXR151	1 1/2" FULL PORT ELECTRIC VALVE	250	1 1/2"	1 1/2"	1	VP20153SH	EVX20200

### MATERIALS

- 316 stainless steel ball & stem
- Stainless steel hardware
- Fiberglass reinforced polypropylene
- PTFE seats
- FKM stem seals

### ON/OFF

- Red = +12V DC
- Black = Ground
- White = +12VDC (Open)  
0VDC (Close)

### 4 WIRE REGULATING

- Red = +12V DC (Open)
- White = Ground (Open)
- Black = +12V DC (Close)
- Green = Ground (Close)

# ELECTRIC VALVES

## 2" EVX SERIES

### FEATURES

- 12-volt DC operated
- 24-volt available
- Open/closed indicator
- ON/OFF has 1½ second response
- Regulating has 4 second response
- Open/Close verification wires available
- IP68 waterproof
- -0 to 150F (-18 to 65C) operating
- -67 to 221F (-55 to 105C) storage
- On/Off Actuator rated to 500,000 cycles
- Regulating Actuator rated to 250,000 cycles
- Valve rated to 50,000 cycles leak-free
- Bolted valves have the same exact dimensions as our legacy EV valves.
- Additional protocols available including CAN/ISO BUS

### MATERIALS

- 316 stainless steel ball & stem
- Stainless steel hardware
- Fiberglass reinforced polypropylene
- PTFE seats
- FKM stem seals

### ON/OFF

- Red = +12V DC
- Black = Ground
- White = +12VDC (Open)  
0VDC (Close)

### 4 WIRE REGULATING

- Red = +12V DC (Open)
- White = Ground (Open)
- Black = +12V DC (Close)
- Green = Ground (Close)



### 2" EVX ON/OFF BOLTED ELECTRIC VALVES

PART NO	DESCRIPTION	MAX PSI	PIPE SIZE	OPENING THRU BALL	QTY	OPTIONAL HANDLE KIT	REPAIR KIT
EVX201	2" STANDARD PORT ELECTRIC VALVE	250	2"	1½"	1	VP20153	EVX20200
EVX221	2" FULL PORT ELECTRIC VALVE	125	2"	2"	1	VP20153	EVX25200

### 2" EVX REGULATING BOLTED ELECTRIC VALVES

PART NO	DESCRIPTION	MAX PSI	PIPE SIZE	OPENING THRU BALL	QTY	OPTIONAL HANDLE KIT	REPAIR KIT
EVXR201	2" STANDARD PORT ELECTRIC VALVE	250	2"	1½"	1	VP20153	EVX20200
EVXR221	2" FULL PORT ELECTRIC VALVE	125	2"	2"	1	VP20153	EVX25200

## 3" EVX SERIES



### FEATURES

- 12-volt DC operated
- 24-volt available
- Open/closed indicator
- ON/OFF has 4 second response
- Regulating has 4 second response
- Open / Close verification available
- IP68 waterproof
- -0 to 150F (-18 to 65C) operating
- -67 to 221F (-55 to 105C) storage
- Actuator rated to 250,000 cycles
- Valve rated to 25,000 cycles leak-free
- Additional protocols available including CAN/ISO BUS

### MATERIALS

- 316 stainless steel ball & stem
- Stainless steel hardware
- Fiberglass reinforced polypropylene
- Zinc alloy lower actuator housing
- PTFE seats
- FKM stem seals

### ON/OFF

- Red = +12V DC
- Black = Ground
- White = +12VDC (Open)  
0VDC (Close)

### 4 WIRE REGULATING

- Red = +12V DC (Open)
- White = Ground (Open)
- Black = +12V DC (Close)
- Green = Ground (Close)

### 3" EVX ON/OFF ELECTRIC VALVES

PART NO	DESCRIPTION	MAX PSI	PIPE SIZE	OPENING THRU BALL	QTY	OPTIONAL HANDLE KIT
EVX300	3" FULL PORT ELECTRIC VALVE	125	3"	3"	1	VP30153

### 3" EVX REGULATING ELECTRIC VALVES

PART NO	DESCRIPTION	MAX PSI	PIPE SIZE	OPENING THRU BALL	QTY	OPTIONAL HANDLE KIT
EVXR300	3" FULL PORT ELECTRIC VALVE	125	3"	3"	1	VP30153

# ELECTRIC VALVES

## 3/4" - 2" EVX SERIES BOTTOM & SIDE LOAD VALVES

### FEATURES

- 12-volt DC operated
- 24-volt available
- Open/closed indicator
- 1" & 1¼" ON/OFF has ¾ second response
- 1½" & 2" ON/OFF has 1½" second response
- Open / Close verification available
- IP68 waterproof
- -0 to 150F (-18 to 65C) operating
- -67 to 221F (-55 to 105C) storage
- On/Off Actuator rated to 500,000 cycles
- Valve rated to 50,000 cycles leak-free
- These bolted valves have the exact same dimensions as our legacy EV valves.
- Additional protocols available including CAN/ISO BUS



### MATERIALS

- 316 stainless steel ball & stem
- Stainless steel hardware
- Fiberglass reinforced polypropylene
- PTFE seats
- FKM stem seals

### ON/OFF

- Red = +12V DC
- Black = Ground
- White = +12VDC (Open)  
0VDC (Close)

### 4 WIRE REGULATING

- Red = +12V DC (Open)
- White = Ground (Open)
- Black = +12V DC (Close)
- Green = Ground (Close)

### 3/4"-2" EVX BOLTED BOTTOM LOAD ELECTRIC VALVES

PART NO	DESCRIPTION	MAX PSI	PIPE SIZE	OPENING THRU BALL	QTY	OPTIONAL HANDLE KIT	REPAIR KIT
EVX075BL	¾" FULL PORT BOTTOM LOAD ELECTRIC VALVE	300	¾"	1"	1	VP20153SH	EVX10200
EVX100BL	1" FULL PORT BOTTOM LOAD ELECTRIC VALVE	300	1"	1"	1	VP20153SH	EVX10200
EVX125BL	1¼" FULL PORT BOTTOM LOAD ELECTRIC VALVE	250	1¼"	1"	1	VP20153SH	EVX10200
EVX150BL	1½" FULL PORT BOTTOM LOAD ELECTRIC VALVE	250	1½"	1½"	1	VP20153SH	EVX20200
EVX200BL	2" STANDARD PORT BOTTOM LOAD ELECTRIC VALVE	250	2"	1½"	1	VP20153	EVX20200
EVX220BL	2" FULL PORT BOTTOM LOAD ELECTRIC VALVE	125	2"	2"	1	VP20153	EVX25200

### ¾"-2" EVX BOLTED SIDE LOAD ELECTRIC VALVES

PART NO	DESCRIPTION	MAX PSI	PIPE SIZE	OPENING THRU BALL	QTY	OPTIONAL HANDLE KIT	REPAIR KIT
EVX075SL	¾" FULL PORT SIDE LOAD ELECTRIC VALVE	300	¾"	1"	1	VP20153SH	EVX10200
EVX100SL	1" FULL PORT SIDE LOAD ELECTRIC VALVE	300	1"	1"	1	VP20153SH	EVX10200
EVX125SL	1¼" FULL PORT SIDE LOAD ELECTRIC VALVE	250	1¼"	1"	1	VP20153SH	EVX10200
EVX150SL	1½" FULL PORT SIDE LOAD ELECTRIC VALVE	250	1½"	1½"	1	VP20153SH	EVX20200
EVX200SL	2" STANDARD PORT SIDE LOAD ELECTRIC VALVE	250	2"	1½"	1	VP20153	EVX20200
EVX220SL	2" FULL PORT SIDE LOAD ELECTRIC VALVE	125	2"	2"	1	VP20153	EVX25200



## FEATURES

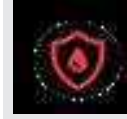

### WATERPROOF

With IP68, IP69, NEMA 6P, and NEMA 7D ratings, you can rest assured that water intrusion is not a concern.



### COST EFFECTIVE

KZ's innovation has kept costs low allowing them to offer a high quality product at a competitive price.



### DURABLE

KZ's highly engineered products are built to last.



A Unit of IDEX Corporation

# ELECTRIC VALVES

## KZVALVE ANHYDROUS AMMONIA VALVES

### FEATURES

- Waterproof, rated NEMA 6P and IP68M
- LED device diagnostics on EH8 and EH9
- Durable, glass filled nylon housing
- Ignition safe, rated NEMA 7D
- 316 stainless steel stem with EPDM O-rings and PTFE packing
- Conxall and Deutsch connections available. WeatherPak harness available separately
- CF8M stainless steel valve body



### NH3 ACTUATED SS VALVE WITH CONXALL CONNECTOR FOR RAVEN SYSTEMS

PART NO	ACTUATOR SERIES	FNPT SIZE	CONTROL TYPE	FEEDBACK	CYCLE TIME	CV	QTY
KZ-67D33-1AE9S-C01	EH9	½"	ON/OFF	(+) @ OPEN	0.7 SEC	15	1
KZ-S8F33-1AE9S-C01	EH9	1" (FP)	ON/OFF	(+) @ OPEN	0.7 SEC	68	1
KZ-S8F33-20E8S-C01	EH9	1" (FP)	FAST RATE	N/A	3.0 SEC	68	1
KZ-S8F22-K0HU0-CF1	EH2	1" (FP)	STANDARD RATE	N/A	8.0 SEC	68	1
KZ-67G22-10DY0-CF1	EH2	1¼"	ON/OFF	N/A	1.5 SEC	48	1
KZ-67G22-20DY0-CF1	EH2	1¼"	FAST RATE	N/A	1.5 SEC	48	1
KZ-67G22-K0HU0-CF1	EH2	1¼"	STANDARD RATE	N/A	8.0 SEC	48	1
KZ-67H22-10DY0-CF1	EH2	1½"	ON/OFF	N/A	1.5 SEC	84	1
KZ-67H22-20DY0-CF1	EH2	1½"	FAST RATE	N/A	1.5 SEC	84	1
KZ-67H22-K0HU0-CF1	EH2	1½"	STANDARD RATE	N/A	8.0 SEC	84	5+

### NH3 ACTUATED SS VALVE WITH INTEGRATED DEUTSCH RECEPTACLE

PART NO	ACTUATOR SERIES	SIZE	CONTROL TYPE	FEEDBACK	CYCLE TIME	CV	QTY
KZ-S2B28-1CEBS-D01	EH8	¼"	ON/OFF	(+) @ CLOSED	0.2 SEC	3.5	5+
KZ-S8C28-1CEBS-D01	EH8	¾"	ON/OFF	(+) @ CLOSED	0.2 SEC	5.2	5+
KZ-67D33-1CE9S-D01	EH9	½" (FP)	ON/OFF	(+) @ CLOSED	0.7 SEC	15	5+
KZ-S8F33-1CE9S-D01	EH9	1" (FP)	ON/OFF	(+) @ CLOSED	0.7 SEC	68	1

### RETROFIT ACTUATOR MOUNTING KITS FOR RAVEN VALVES

PART NO	DESCRIPTION	SIZE	QTY
KZ-KRKIT	ACTUATOR MOUNTING KIT FOR 1 & 1 1/4" RAVEN VALVES	1 & 1¼"	1
KZ-KR15KIT	ACTUATOR MOUNTING KIT FOR 1 1/2" RAVEN VALVES	1 ½"	1



### ACTUATOR ONLY

PART NO	ACTUATOR SERIES	CONTROL TYPE	FOR VALVE BRAND	FOR VALVE SIZES	CYCLE TIME	QTY
KZ-20DY0-CF1 *	EH2	FAST RATE	RAVEN	1 - 1 1/2"	1.5 SEC	1
KZ-10DY0-CF1 *	EH2	ON/OFF	RAVEN	1 - 1 1/2"	1.5 SEC	1
KZ-K0HU0-CF1 *	EH2	STANDARD RATE	RAVEN	1 - 1 1/2"	8.0 SEC	1
KZ-20E8S-C01	EH9	FAST RATE	KZVALVE	UP TO 1"	1.5 SEC	1
KZ-1CE9S-D01	EH9	ON/OFF	KZVALVE	UP TO 1"	0.7 SEC	5+
KZ-20E7S-D01	EH9	STANDARD RATE	KZVALVE	UP TO 1"	3 SEC	5+
KZ-20E8S-D01	EH9	FAST RATE	KZVALVE	UP TO 1"	1.7 SEC	5+
KZ-1AE9S-C01	EH9	ON/OFF	KZVALVE	UP TO 1"	0.7 SEC	1

\* REQUIRES PROPER RETROFIT ACTUATOR MOUNTING KIT



- Retrofit Actuator Mounting Kit Includes

- Coupler
- Mounting Bracket
- Fasteners
- Simple Instructions

\* These actuators are designed to replace Raven actuators on Raven valves. They require a retrofit actuator mounting kit.

## KZVALVE SERIES 95 VALVES



### FEATURES

- Waterproof, rated NEMA 6P and IP68M
- NSF61 Certified
- LED device diagnostics
- Durable, glass filled nylon housing
- Ignition safe, rated NEMA 7D
- Low maintenance, reversible seat design
- Integrated Deutsch receptacle connection
- Hayward valve assembly
  - PVC valve body
  - PVC ball
  - FNPT and Socket Weld endplates included

### SERIES 95 ACTUATED PVC VALVES

PART NO	ACTUATOR SERIES	SIZE	OUTLET	CONTROL TYPE	QTY
KZ-95D33-1CE9S-D0P	EH9	½"	FNPT/SOCKET WELD	ON/OFF	1
KZ-95F33-1CE9S-D0P	EH9	1"	FNPT/SOCKET WELD	ON/OFF	1

### SERIES 95 PVC VALVE ONLY

PART NO	DESCRIPTION	SIZE	OUTLET	PSI @ 70	CV	QTY
KZ-95D33	½" VALVE SUBASSEMBLY	½"	FNPT/SOCKET WELD	250	8.0	5+
KZ-95E33	¾" VALVE SUBASSEMBLY	¾"	FNPT/SOCKET WELD	250	16.0	5+
KZ-95F33	1" VALVE SUBASSEMBLY	1"	FNPT/SOCKET WELD	250	29.0	5+
KZ-95H39	1 ½" VALVE SUBASSEMBLY	1 ½"	FNPT/SOCKET WELD	125	90.0	5+
KZ-95I39	2" VALVE SUBASSEMBLY	2"	FNPT/SOCKET WELD	125	150.0	5+

### ACTUATOR ONLY

PART NO	ACTUATOR SERIES	CONTROL TYPE	CYCLE TIME	QTY
KZ-20E7S-D0P	EH9	POSITIONABLE	3.0 SEC	5+
KZ-20E8S-D0P	EH9	POSITIONABLE	1.7 SEC	5+
KZ-20E9S-D0P	EH9	POSITIONABLE	0.7 SEC	5+
KZ-1CE7S-D0P	EH9	ON/OFF	3.0 SEC	5+
KZ-1CE8S-D0P	EH9	ON/OFF	1.37 SEC	5+
KZ-1CE9S-D0P	EH9	ON/OFF	0.7 SEC	5+
KZ-L0E7S-D0P	EH9	CANBUS	3.0 SEC	5+



# ELECTRIC VALVES



## FEATURES

- Waterproof, rated NEMA 6P and IP68
- LED device diagnostics on EH8 and EH9
- Durable, glass filled nylon housing
- Ignition safe, rated NEMA 7D
- Integrated Deutsch DT04-4 Pin connection
- 12 and 24 VDC capable
- Extremely low continuous power consumption
- High flow capacity in a compact valve design



### 2 WAY NYLON ZIPVALVES

PART NO	DESCRIPTION	PORT SIZE	CONTROL TYPE	FEEDBACK	CYCLE TIME	QTY
KZ-NAZC28-1CEBS-D01	EH8, MALE QD ENDS	3/8"	ON/OFF	N/A	0.2 SEC	1
KZ-NAZC28-1CEBS-R01	EH8, MALE QD ENDS	3/8"	ON/OFF	N/A	0.2 SEC	5+
KZ-NMZB28-1CEBS-D01	EH8, 1/4" MNPT	1/4"	ON/OFF	N/A	0.2 SEC	5+
KZ-NMZB28-1CEBS-R01	EH8, 1/4" MNPT	1/4"	ON/OFF	N/A	0.2 SEC	5+
KZ-NPZC28-1CEBS-D01	EH8, 3/8" PUSH LOCK	3/8"	ON/OFF	N/A	0.2 SEC	1
KZ-NPZC28-1CEBS-R01	EH8, 3/8" PUSH LOCK	3/8"	ON/OFF	N/A	0.2 SEC	5+
KZ-NQZC28-1CEBS-D01	EH8, 1/2" PUSH LOCK	3/8"	ON/OFF	N/A	0.2 SEC	1
KZ-NQZC28-1CEBS-R01	EH8, 1/2" PUSH LOCK	3/8"	ON/OFF	N/A	0.2 SEC	5+

### 3 WAY NYLON ZIPVALVES

PART NO	DESCRIPTION	SIZE	CONTROL TYPE	FEEDBACK	CYCLE TIME	CV	QTY
KZ-NA4C28-1CEBS-D0V	EH8, BL, MALE QD ENDS	3/8"	ON/OFF	N/A	0.4 SEC		5+



### WIRE HARNESES

PART NO	DESCRIPTION	QTY
KZ-398-0276	FLYING LEADS	5+
KZ-398-0758	AMP 3PIN W/ BOOT 1B2R3W	5+



### ZIPVALVE MOUNTING BRACKETS

PART NO	DESCRIPTION	QTY
KZ-511-0154	SS BASE BRACKET KIT	5+
KZ-511-0156	NYLON BRACKET KIT	5+

## KZVALVE QD FITTINGS



QD FITTING KITS		
PART NO	DESCRIPTION	QTY
KZ-511-0012	F QD X 3/4" BARB KIT	5+
KZ-511-0013	F QD X 1" BARB KIT	5+
KZ-511-0014	F QD X 3/4" BARB 90 KIT	5+
KZ-511-0015	F QD X 1" BARB 90 KIT	5+
KZ-511-0019	F QD X 1/2" FPT KIT	5+
KZ-511-0026	F QD X 1/2" BARB KIT	5+
KZ-511-0027	F QD X 1/2" BARB 90 KIT	5+
KZ-511-0028	F QD X M100 KIT	5+

### FEATURES

- Quick installation on valve bodies that utilize the QD fork connection
- Allows for a highly customizable system
- Female Fitting Kit Includes
  - Fitting
  - SS Fork
  - Silicone grease pack
- Male Fitting Kit Includes
  - Fitting
  - EPDM o'ring
  - Silicone grease pack

## LEV TRANSITION TO ZIPVALVE

LEV PART NO	=	ZIPVALVE	+ [Red Plus]	FITTING KIT (x2)	+ [Red Plus]	WIRE HARNESS
LEV038		KZ-NAZC28-1CEBS-D01		KZ-511-0019 + RB050-038		KZ-398-0276
LEV050		KZ-NAZC28-1CEBS-D01		KZ-511-0019		KZ-398-0276
MLEV100		KZ-NAZC28-1CEBS-D01		KZ-511-0028		KZ-398-0276
LEV038PL		KZ-NPZC28-1CEBS-D01		NONE		KZ-398-0276



- Banjo's LEV series has been replaced by the ZIPValves
- When replacing an LEV valve, choose the following components:
  - ZIPValve
  - Fitting Kits
  - Wire Harness

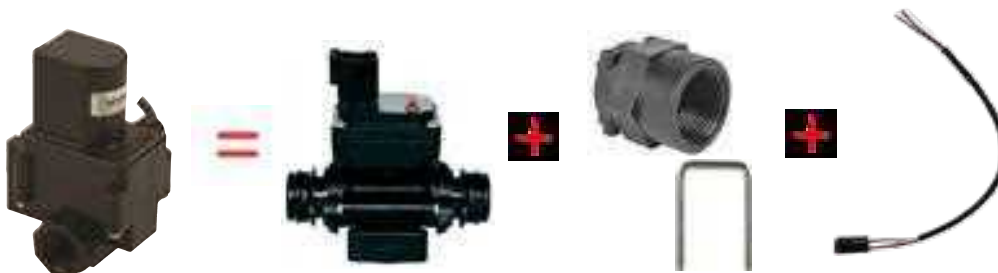

# ELECTRIC VALVES

## KZVALVE BANKED ZIPVALVE MANIFOLDS

### FEATURES

- Banked valves have male QD connections (adapters shown are not included)
- Valves have an Integrated Deutsch DT04-4 Pin connection
- Quick installation of QF fittings creating valve banks
- Allows for a highly customizable system



### BANKED ZIPVALVE MANIFOLDS

PART NO	DESCRIPTION	CONTROL TYPE	SIZE	FEEDBACK	CYCLE TIME	QTY
KZ-11AA2-1CEBS-D01	EH8, QD ENDS	ON/OFF	3/8"	(+) @ CLOSED	0.2 SEC	1
KZ-13AA2-1CEBS-D01	EH8, QD ENDS, 3 BANK	ON/OFF	3/8"	(+) @ CLOSED	0.2 SEC	1
KZ-14AA2-1CEBS-D01	EH8, QD ENDS, 4 BANK	ON/OFF	3/8"	(+) @ CLOSED	0.2 SEC	1



### QD FITTING KITS FOR VALVE

PART NO	DESCRIPTION	QTY
KZ-511-0012	F QD X 3/4" BARB KIT	5+
KZ-511-0013	F QD X 1" BARB KIT	5+
KZ-511-0014	F QD X 3/4" BARB 90 KIT	5+
KZ-511-0015	F QD X 1" BARB 90 KIT	5+
KZ-511-0019	F QD X 1/2" FPT KIT	5+
KZ-511-0026	F QD X 1/2" BARB KIT	5+
KZ-511-0027	F QD X 1/2" BARB 90 KIT	5+
KZ-511-0028	F QD X M100 KIT	5+

- QD - Polypropylene
- QF - Nylon
- Allows for a highly customizable system
- Female Fitting Kit Includes
  - Fitting
  - SS Fork
  - Silicone grease pack
- Male Fitting Kit Includes
  - Fitting
  - EPDM o'ring
  - Silicone grease pack

### QF FITTING KITS FOR MANIFOLD LINE

PART NO	DESCRIPTION	QTY
KZ-511-0168	F QF X 1" BARB KIT	5+
KZ-511-0167	F QF X M100 KIT	5+
KZ-511-0171	M QF X 1" BARB KIT	5+
KZ-511-0170	M QF X BLANK CAP - EPDM KIT	5+
KZ-211-0372	M QF X M100 (FITTING ONLY)	5+
KZ-211-0369	F QF X M200 (FITTING ONLY)	5+
KZ-203-0064	QF TEE- FQFXMQFXFQD (FITTING ONLY)	5+
KZ-106-0031	QF SS FORK	5+
KZ-205-0161	QF SERIES EPDM GASKET	5+
KZ-205-0181	QF SERIES FKM GASKET	5+

## KZVALVE BANKED TX2 VALVE MANIFOLDS



### FEATURES

- Banked valves have male QD connections that come standard with one end capped (adapters shown are not included)
- Valves have an Integrated Deutsch DT04-4 Pin connection
- Quick installation M100 manifold flanges create valve banks
- Allows for a highly customizable system
- Regulating bypass has a WeatherPak connector

### BANKED TX2 MANIFOLDS

PART NO	DESCRIPTION	CONTROL TYPE	SIZE	FEEDBACK	CYCLE TIME	QTY
KZ-21CA9-1CEFS-D01	EH6, QD ENDS	ON/OFF	½"	(+) @ CLOSED	0.5 SEC	1
KZ-22CA9-1CEFS-D01	EH6, QD ENDS, 2 BANK	ON/OFF	½"	(+) @ CLOSED	0.5 SEC	1
KZ-23CA9-1CEFS-D01	EH6, QD ENDS, 3 BANK	ON/OFF	½"	(+) @ CLOSED	0.5 SEC	1
KZ-25CA9-1CEFS-D01	EH6, QD ENDS, 5 BANK	ON/OFF	½"	(+) @ CLOSED	0.5 SEC	1

### COMPATIBLE REGULATING BYPASS

PART NO	DESCRIPTION	CONTROL TYPE	SIZE	FEEDBACK	CYCLE TIME	QTY
KZ-21CAA-20DJ0-P0L	EH7, QD ENDS, V BALL, 12VDC	REG	½"	N/A	7 SEC	



### QD FITTING KITS FOR VALVE

PART NO	DESCRIPTION	QTY
KZ-511-0012	F QD X 3/4" BARB KIT	5+
KZ-511-0013	F QD X 1" BARB KIT	5+
KZ-511-0014	F QD X 3/4" BARB 90 KIT	5+
KZ-511-0015	F QD X 1" BARB 90 KIT	5+
KZ-511-0019	F QD X 1/2" FPT KIT	5+
KZ-511-0026	F QD X 1/2" BARB KIT	5+
KZ-511-0027	F QD X 1/2" BARB 90 KIT	5+
KZ-511-0028	F QD X M100 KIT	5+

- QD - Polypropylene
- Allows for a highly customizable system
- Female Fitting Kit Includes
  - Fitting
  - SS Fork
  - Silicone grease pack
- Male Fitting Kit Includes
  - Fitting
  - EPDM o'ring
  - Silicone grease pack

SEE BANJO'S MANIFOLD FLANGE FITTINGS CATALOG SECTION FOR M100 CONNECTIONS FOR MANIFOLD LINE

# ELECTRIC VALVES



## FEATURES



### TX2 SERIES POLYPROPYLENE VALVES

PART NO	DESCRIPTION	CONTROL TYPE	SIZE	FEEDBACK	CYCLE TIME	QTY
KZ-21CA9-1CEFS-D01	EH6, MALE QD ENDS	ON/OFF	1/2"	(+) @ CLOSED	0.5 SEC	5+
KZ-C2D37-1CEFS-D01	EH6, M100	ON/OFF	1/2"	(+) @ CLOSED	0.5 SEC	5+
KZ-G2D37-1CEFS-D01	EH6, M100 X QD	ON/OFF	1/2"	(+) @ CLOSED	0.5 SEC	5+
KZ-H2D37-1CEFS-D01	EH6, QD ENDS	ON/OFF	1/2"	(+) @ CLOSED	0.5 SEC	5+
KZ-H7D37-1CEFS-D01	EH6, QD ENDS, BOTTOM LOAD	ON/OFF	1/2"	(+) @ CLOSED	0.5 SEC	5+

### S SERIES STAINLESS STEEL VALVES

PART NO	DESCRIPTION	CONTROL TYPE	PORT SIZE	CYCLE TIME	QTY
KZ-KZ1733-1CEBS-D01	EH8, 3/4" MNPT	ON/OFF	3/8"	0.2 SEC	5+
KZ-KZ1754-1CEBS-D01	EH8, 1/2" MNPT	ON/OFF	3/8"	0.2 SEC	5+
KZ-S2B28-1CEBS-D01	EH8, 1/4" FNPT	ON/OFF	1/4"	0.2 SEC	5+
KZ-S2C28-1CEBS-D01	EH8, 3/8" FNPT	ON/OFF	3/8"	0.2 SEC	5+
KZ-S2F33-1CE9S-D01	EH9, 1" FNPT	ON/OFF	1"	0.7 SEC	5+
KZ-S4F22-90EYS-DFV	EH9, 1" FNPT, BOTTOM LOAD	ON/OFF/ON	1"	3 SEC	5+
KZ-S4H22-90EYS-DFV	EH9, 1 1/2" FNPT, BOTTOM LOAD	ON/OFF/ON	1 1/2"	3 SEC	5+



### QX SERIES POLYPROPYLENE VALVES

PART NO	DESCRIPTION	CONTROL TYPE	CYCLE TIME	QTY
KZ-F2E33-1CE9S-D01	EH9, 3/4" FNPT, SS BALL	ON/OFF	0.7 SEC	5+
KZ-F2F33-1CE9S-D01	EH9, 1" FNPT, SS BALL	ON/OFF	0.7 SEC	5+
KZ-F2H22-10EYS-PF1	EH2, 1 1/2" FNPT, SS BALL	ON/OFF	1.5 SEC	5+
KZ-F4F33-1CE9S-D0V	EH3, 1" FNPT, BOTTOM LOAD, SS BALL	ON/OFF/ON	1.6 SEC	5+

## FEATURES



### TRU-TORQUE VALVES

PART NO	DESCRIPTION	CONTROL TYPE	CYCLE TIME	QTY
KZ-M4K22-10DW0-PFV	EH2, M300, BOTTOM LOAD	ON/OFF/ON	6 SEC	5+
KZ-T2H22-10EYS-PF1	EH2, M200, SS BALL	ON/OFF	1.5 SEC	5+

### 84 SERIES BRONZE VALVES

PART NO	DESCRIPTION	CONTROL TYPE	CYCLE TIME	QTY
KZ-84B23-1CE9S-D01	EH3, 1/4" FNPT	ON/OFF	0.7 SEC	5+
KZ-84D23-1CE9S-D01	EH3, 1/2" FNPT	ON/OFF	0.7 SEC	5+



### 88 SERIES STAINLESS STEEL VALVES

PART NO	DESCRIPTION	CONTROL TYPE	CYCLE TIME	QTY
KZ-88D33-1CE9S-D01	EH3, 1/2" FNPT	ON/OFF	0.7 SEC	5+
KZ-88H22-10EYS-PF1	EH2, 1 1/2" FNPT	ON/OFF	1.5 SEC	5+

### SERIES 89 STAINLESS STEEL 3 PIECE VALVES

PART NO	DESCRIPTION	CONTROL TYPE	CYCLE TIME	QTY
KZ-89D33-1CE9S-D01	EH3, 1/2" FNPT	ON/OFF	0.7 SEC	5+
KZ-89H22-10EYS-PF1	EH2, 1 1/2" FNPT	ON/OFF	1.5 SEC	5+



# MANIFOLD FLANGE CONNECTIONS

NO THREADS. NO SWEAT.

FLANGE CONNECTIONS FOR EVERY PRODUCT

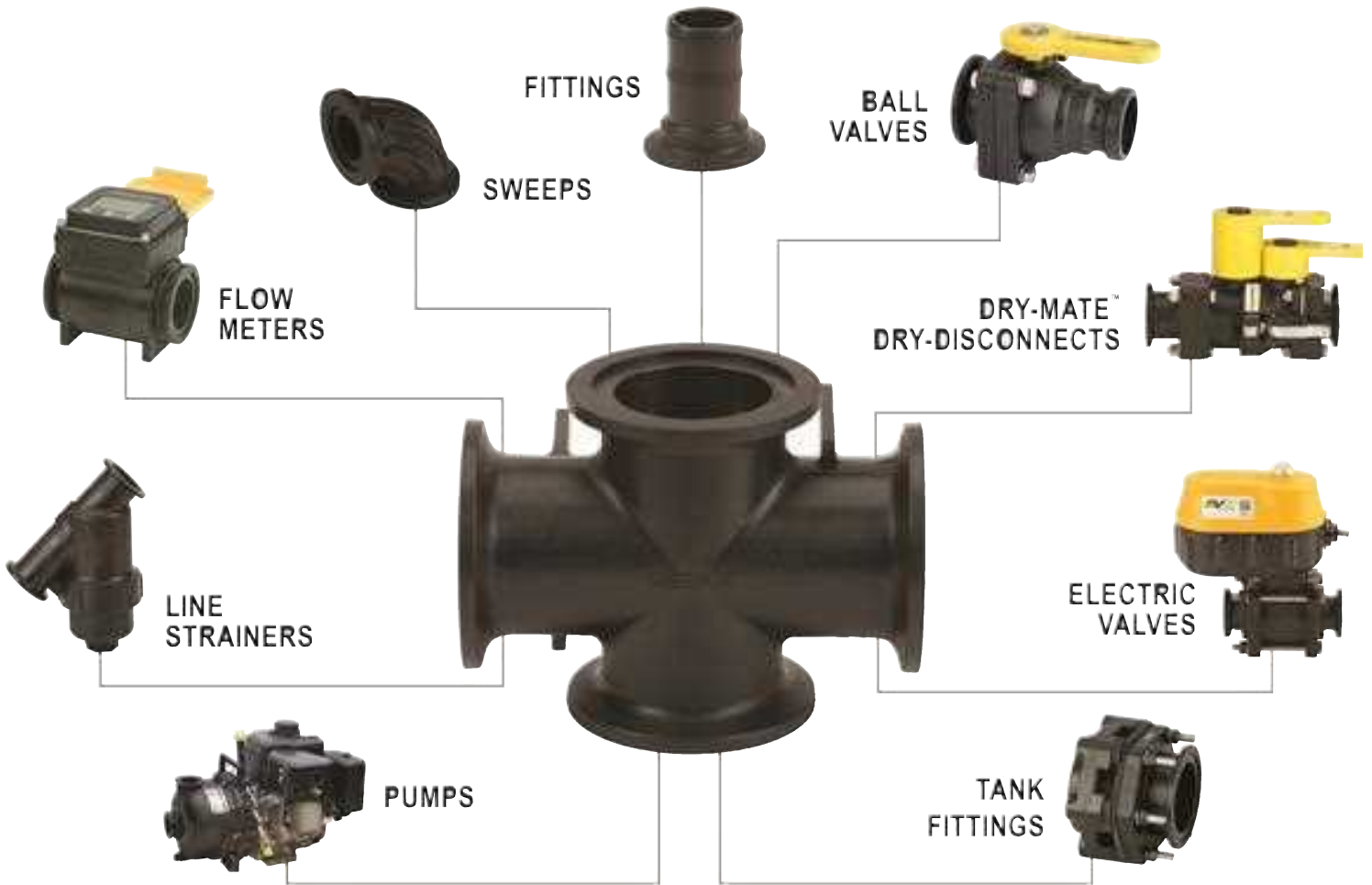

## ⚡ SKIP THE TAPE AND SEALANT

Flange connections utilize clamps instead of threads, facilitating quick and easy assembly and disassembly while ensuring a leak-proof system. Threaded pipe needs tape or sealant, and the slightest imperfection in the pipe or seal can cause a leak. With properly installed flange connections, you won't worry about connection leaks or wait for sealant to cure.

## ⌚ SAVE TIME. SAVE MONEY.

Time spent unthreading systems and repairing leaks from faulty connections is unproductive and ultimately hits your pocketbook. Banjo's manifold flange systems get you back in the field and out of the shop in no time.

## ➡ GET RIGHT TO THE SOURCE

With Banjo manifold flange connections, the days of spending hours unhooking entire systems of valves and fittings are over. You can directly isolate and replace the problematic part or replumb sections without disassembling the whole system.

# MANIFOLD FLANGE CONNECTIONS



## 1" MEVX SERIES

### FEATURES

- 12-volt DC operated
- 24-volt available
- Open/closed indicator
- ON/OFF has 3/4 second response
- Regulating has 4 second response
- Open / Close verification available
- IP68 waterproof
- -0 to 150F (-18 to 65C) operating
- -67 to 221F (-55 to 105C) storage
- On/Off Actuator rated to 500,000 cycles
- Regulating Actuator rated to 250,000 cycles
- Valve rated to 50,000 cycles leak-free
- Bolted valves have the same exact dimensions as our legacy EV valves.
- Additional protocols available including CAN/ISO BUS

### MATERIALS

- 316 stainless steel ball & stem
- Poly ball available on bolted valves
- Stainless steel hardware
- Fiberglass reinforced polypropylene
- PTFE seats
- FKM stem seals

### ON/OFF

- Red = +12V DC
- Black = Ground
- White = +12VDC (Open)  
0VDC (Close)

### 4 WIRE REGULATING

- Red = +12V DC (Open)
- White = Ground (Open)
- Black = +12V DC (Close)
- Green = Ground (Close)

### 1" MEVX ON/OFF WELDED ELECTRIC VALVES

PART NO	DESCRIPTION	MAX PSI	PIPE SIZE	OPENING THRU BALL	QTY	OPTIONAL HANDLE KIT
MEVX100	1" FULL PORT ELECTRIC VALVE	300	1"	1"	1	VP20153SH

### 1" MEVX REGULATING WELDED ELECTRIC VALVES

PART NO	DESCRIPTION	MAX PSI	PIPE SIZE	OPENING THRU BALL	QTY	OPTIONAL HANDLE KIT
MEVXR100	1" FULL PORT ELECTRIC VALVE	300	1"	1"	1	VP20153SH

### 1" MEVX ON/OFF BOLTED ELECTRIC VALVES

PART NO	DESCRIPTION	MAX PSI	PIPE SIZE	OPENING THRU BALL	QTY	OPTIONAL HANDLE KIT	REPAIR KIT
MEVX101	1" FULL PORT ELECTRIC VALVE	300	1"	1"	1	VP20153SH	EVX10200

### 1" MEVX REGULATING BOLTED ELECTRIC VALVES

PART NO	DESCRIPTION	MAX PSI	PIPE SIZE	OPENING THRU BALL	QTY	OPTIONAL HANDLE KIT	REPAIR KIT
MEVXR101	1" FULL PORT ELECTRIC VALVE	300	1"	1"	1	VP20153SH	EVX10200

# MANIFOLD FLANGE CONNECTIONS

## 2" MEVX SERIES

### FEATURES

- 12-volt DC operated
- 24-volt available
- Open/closed indicator
- ON/OFF has 1½ second response
- Regulating has 4 second response
- Open / Close verification available
- IP68 waterproof
- -0 to 150F (-18 to 65C) operating
- -67 to 221F (-55 to 105C) storage
- On/Off Actuator rated to 500,000 cycles
- Regulating Actuator rated to 250,000 cycles
- Valve rated to 50,000 cycles leak-free
- Bolted valves have the same exact dimensions as our legacy EV valves.
- Additional protocols available including CAN/ISO BUS

### MATERIALS

- 316 stainless steel ball & stem
- Poly ball available on bolted standard port valves
- Stainless steel hardware
- Fiberglass reinforced polypropylene
- PTFE seats
- FKM stem seals

### ON/OFF

- Red = +12V DC
- Black = Ground
- White = +12VDC (Open)  
0VDC (Close)

### 4 WIRE REGULATING

- Red = +12V DC (Open)
- White = Ground (Open)
- Black = +12V DC (Close)
- Green = Ground (Close)



### 2" MEVX ON/OFF WELDED ELECTRIC VALVES

PART NO	DESCRIPTION	MAX PSI	PIPE SIZE	OPENING THRU BALL	QTY	OPTIONAL HANDLE KIT
MEVX200	2" STANDARD PORT ELECTRIC VALVE	300	2"	1½"	1	VP20153
MEVX220	2" FULL PORT ELECTRIC VALVE	250	2"	2"	1	VP20153

### 2" MEVX REGULATING WELDED ELECTRIC VALVES

PART NO	DESCRIPTION	MAX PSI	PIPE SIZE	OPENING THRU BALL	QTY	OPTIONAL HANDLE KIT
MEVXR200	2" STANDARD PORT ELECTRIC VALVE	250	2"	1½"	1	VP20153
MEVXR220	2" FULL PORT ELECTRIC VALVE	250	2"	2"	1	VP20153

### 2" MEVX ON/OFF BOLTED ELECTRIC VALVES

PART NO	DESCRIPTION	MAX PSI	PIPE SIZE	OPENING THRU BALL	QTY	OPTIONAL HANDLE KIT	REPAIR KIT
MEVX201	2" STANDARD PORT ELECTRIC VALVE	250	2"	1½"	1	VP20153	EVX20200
MEVX221	2" FULL PORT ELECTRIC VALVE	125	2"	2"	1	VP20153	EVX25200

# MANIFOLD FLANGE CONNECTIONS



## 3" MEVX SERIES

### FEATURES

- 12-volt DC operated
- 24-volt available
- Open/closed indicator
- ON/OFF 3" has 4 second response
- Regulating 3" has 4 second response
- Open / Close verification available
- IP68 waterproof
- -0 to 150F (-18 to 65C) operating
- -67 to 221F (-55 to 105C) storage
- Actuator rated to 250,000 cycles
- Valve rated to 25,000 cycles leak-free
- Additional protocols available including CAN/ISO BUS

### MATERIALS

- 316 stainless steel ball & stem
- Stainless steel hardware
- Fiberglass reinforced polypropylene
- Zinc alloy lower actuator housing
- PTFE seats
- FKM stem seals

### ON/OFF

- Red = +12V DC
- Black = Ground
- White = +12VDC (Open)  
0VDC (Close)

### 4 WIRE REGULATING

- Red = +12V DC (Open)
- White = Ground (Open)
- Black = +12V DC (Close)
- Green = Ground (Close)

### 3" MEVX ON/OFF ELECTRIC VALVES

PART NO	DESCRIPTION	MAX PSI	PIPE SIZE	OPENING THRU BALL	QTY
MEVX300	3" FULL PORT ELECTRIC VALVE	125	3"	3"	1

### 3" MEVX REGULATING ELECTRIC VALVES

PART NO	DESCRIPTION	MAX PSI	PIPE SIZE	OPENING THRU BALL	QTY
MEVXR300	3" FULL PORT ELECTRIC VALVE	125	3"	3"	1

# MANIFOLD FLANGE CONNECTIONS

## 1"- 3" MEVX SERIES BOTTOM & SIDE LOAD VALVES

### FEATURES

- 12-volt DC operated
- 24-volt available
- Open/closed indicator
- ON/OFF 1" has ¾ second response
- ON/OFF 2" has 1½ second response
- ON/OFF 3" has 4 second response
- Open / Close verification available
- IP68 waterproof
- -0 to 150F (-18 to 65C) operating
- -67 to 221F (-55 to 105C) storage
- 1"-2" On/Off Actuator rated to 500,000 cycles
- 3" On/Off & Regulating Actuator rated to 250,000 cycles
- Valve rated to 50,000 cycles leak-free
- Additional protocols available including CAN/ISO BUS

### MATERIALS

- 316 stainless steel ball & stem
- Stainless steel hardware
- Fiberglass reinforced polypropylene
- Zinc alloy lower actuator housing (3" only)
- PTFE seats
- FKM stem seals

### ON/OFF

- Red = +12V DC
- Black = Ground
- White = +12VDC (Open)  
0VDC (Close)

### 4 WIRE REGULATING

- Red = +12V DC (Open)
- White = Ground (Open)
- Black = +12V DC (Close)
- Green = Ground (Close)



### 1"-3" MEVX BOTTOM LOAD ELECTRIC VALVES

PART NO	DESCRIPTION	MAX PSI	PIPE SIZE	OPENING THRU BALL	QTY	OPTIONAL HANDLE KIT	REPAIR KIT
MEVX100BL	1" FULL PORT MANIFOLD BOTTOM LOAD ELECTRIC VALVE	300	1"	1"	1	VP20153SH	EVX10200
MEVX200BL	2" STANDARD PORT MANIFOLD BOTTOM LOAD ELECTRIC VALVE	250	2"	1½"	1	VP20153	EVX20200
MEVX220BL	2" FULL PORT MANIFOLD BOTTOM LOAD ELECTRIC VALVE	125	2"	2"	1	VP20153	EVX25200
MEVX300BL	3" FULL PORT MANIFOLD BOTTOM LOAD ELECTRIC VALVE	125	3"	3"	1	VP30153	EVX30200

### 1"-2" MEVX SIDE LOAD ELECTRIC VALVES

PART NO	DESCRIPTION	MAX PSI	PIPE SIZE	OPENING THRU BALL	QTY	OPTIONAL HANDLE KIT	REPAIR KIT
MEVX100SL	1" FULL PORT MANIFOLD SIDE LOAD ELECTRIC VALVE	300	1"	1"	1	VP20153SH	EVX10200
MEVX200SL	2" STANDARD PORT MANIFOLD SIDE LOAD ELECTRIC VALVE	250	2"	1½"	1	VP20153	EVX20200
MEVX220SL	2" FULL PORT MANIFOLD SIDE LOAD ELECTRIC VALVE	125	2"	2"	1	VP20153	EVX25200

### 1"-2" MEVX SIDE LOAD REGULATING ELECTRIC VALVES

PART NO	DESCRIPTION	MAX PSI	PIPE SIZE	OPENING THRU BALL	QTY	OPTIONAL HANDLE KIT	REPAIR KIT
MEVXR100SL	1" FULL PORT MANIFOLD SIDE LOAD ELECTRIC VALVE	300	1"	1"	1	VP20153SH	EVX10200
MEVXR200SL	2" STANDARD PORT MANIFOLD SIDE LOAD ELECTRIC VALVE	250	2"	1½"	1	VP20153	EVX20200
MEVXR220SL	2" FULL PORT MANIFOLD SIDE LOAD ELECTRIC VALVE	125	2"	2"	1	VP20153	EVX25200

# MANIFOLD FLANGE CONNECTIONS



## MEVX BANKED VALVES

### FEATURES

- Valve sizes 1"-2" SP
- Number of valves from two to five bank
- Welded or bolted valves available
- Bolted valves have the same exact dimensions as our legacy EV valves.
- Additional protocols available including CAN/ISO BUS

### MEVX ON/OFF WELDED BANKED ELECTRIC VALVES

PART NO	DESCRIPTION	MAX PSI	PIPE SIZE	OPENING THRU BALL	QTY
MEVX102	1" FULL PORT 2 BANK ELECTRIC VALVE	300	1"	1"	1
MEVX103	1" FULL PORT 3 BANK ELECTRIC VALVE	300	1"	1"	1

### MEVX ON/OFF BOLTED BANKED ELECTRIC VALVES

PART NO	DESCRIPTION	MAX PSI	PIPE SIZE	OPENING THRU BALL	QTY
MEVX1012	1" FULL PORT 2 BANK ELECTRIC VALVE	300	1"	1"	1
MEVX1013	1" FULL PORT 3 BANK ELECTRIC VALVE	300	1"	1"	1
MEVX1014	1" FULL PORT 4 BANK ELECTRIC VALVE	300	1"	1"	1
MEVX2013	2" STANDARD PORT ELECTRIC VALVE	300	2"	2"	1

### LEV TRANSITION TO ZIPVALVE

LEV PART NO	ZIPVALVE	FITTING KIT (x2)	WIRE HARNESS
MLEV100	KZ-NAZC28-1CEBS-D01	KZ-511-0028	KZ-398-0276

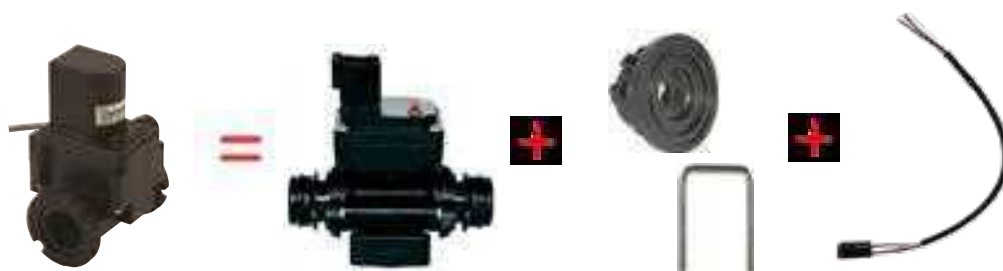

SEE KZVALVE SECTION ON PAGE 29 FOR ADDITIONAL OPTIONS

## 1" LEV ELECTRIC MANIFOLD VALVE



- Banjo's LEV series has been replaced by the ZIPValves
- When replacing an LEV valve, choose the following components:
  - ZIPValve
  - Fitting Kits
  - Wire Harness

# MANIFOLD FLANGE CONNECTIONS

## 1" - 3" 4 & 6 BOLTED VALVES

### FEATURES

- FKM seals.
- Precision molded polypropylene is reinforced with fiberglass for additional strength
- Self-aligning ball moves freely against the PTFE seats for smooth operation. The valve opens and closes with very little pressure on the handle
- Ball is diamond turned, after molding, to make it spherically perfect, which provides precise contact between ball and seats.
- PTFE self-lubricating stem bushings and seats cannot stick or bind
- Stainless steel bolts

### REPAIR KIT INCLUDES:

- Ball
- Body gasket
- Thrust washer
- Ball seats
- Upper stem bushing
- Stem o-ring



MV200CF

MV300CF

### MANIFOLD 4 & 6 BOLTED VALVES

PART NO	DESCRIPTION	MAX PSI	PIPE SIZE	OPENING THRU BALL	LOT QTY	REPLACEMENT HANDLE	REPAIR KIT
MV100CF	1" FULL PORT MANIFOLD VALVE	300	1"	1"	12	V10153A	V10200
MV200CF	2" STANDARD PORT MANIFOLD VALVE	225	2"	1½"	12/BOX	V20153	V20200
MV220CF	2" FULL PORT MANIFOLD VALVE	300	2"	2"	8/BOX	V25153	V25200
MV300	3" STANDARD PORT MANIFOLD VALVE	150	3"	2½"	6/BOX	V25153	V30200
MV300CF	3" FULL PORT MANIFOLD VALVE	200	3"	3"	6/BOX	V25153	V35200

## 2" BOLTED 5 WAY VALVE

### FEATURES

- FKM seals
- Precision molded polypropylene is reinforced with fiberglass for additional strength
- Self-aligning ball moves freely against the PTFE seats for smooth operation. The valve opens and closes with very little pressure on the handle
- Ball is diamond turned, after molding, to make it spherically perfect, which provides precise contact between ball and seats.
- PTFE self-lubricating stem bushings and seats cannot stick or bind
- Stainless steel bolts



### MANIFOLD BOLTED 5 WAY VALVE

PART NO	DESCRIPTION	MAX PSI	PIPE SIZE	OPENING THRU BALL	QTY	REPAIR KIT
MV225CF	2" FULL PORT MANIFOLD 5 WAY VALVE	100	2"	2"	1	V25500A

# MANIFOLD FLANGE CONNECTIONS

## 2" STUBBY VALVES



VSMT200CF



VSF200CF



MVS220FP



MVSF220FP



MVS220CF



MVSMT220FP

### FEATURES

- Precision molded polypropylene is reinforced with fiberglass for additional strength.
- Self-aligning ball moves freely against the PTFE seats for smooth operation. The valve opens and closes with very little pressure on the handle.
- Ball is diamond turned, after molding, to make it spherically perfect, which provides precise contact between ball and seats.
- PTFE self-lubricating stem bushings and seats cannot stick or bind.
- Stainless steel bolts.
- Standard port size has TFE seals and Full Port size has FKM seals

### 2" MANIFOLD STUBBY VALVES

PART NO	DESCRIPTION	MAX PSI	PIPE SIZE	OPENING THRU BALL	LOT QTY	REPLACEMENT HANDLE	REPAIR KIT
VSMT200CF	2" STANDARD PORT MANIFOLD VALVE FLANGE X MALE NPT W/TFE SEALS	150	2"	1½"	6	VS20152SH	VS20200
VSF200CF	2" STANDARD PORT MANIFOLD VALVE FLANGE X MALE ADAPTER W/TFE SEALS	100	2"	1½"	6	VS20152SH	VS20200
MVS220FP	2" FULL PORT MANIFOLD VALVE FLANGE X FEMALE NPT W/FKM SEALS	300	2"	2"	6	VS25153	VS25200
MVSF220FP	2" FULL PORT MANIFOLD VALVE FLANGE X MALE ADAPTER W/FKM SEALS	150	2"	2"	9	VS25153	VS25200
MVS220CF	2" FULL PORT MANIFOLD VALVE FLANGE X FLANGE W/FKM SEALS	150	2"	2"	9	VS25153	VS25200
MVSMT220FP	2" FULL PORT MANIFOLD VALVE FLANGE X MALE NPT W/FKM SEALS	225	2"	2"	9	VS25153	VS25200

# MANIFOLD FLANGE CONNECTIONS

## 3" STUBBY VALVES

### FEATURES

- FKM seals.
- Precision molded polypropylene is reinforced with fiberglass for additional strength.
- Self-aligning ball moves freely against the PTFE seats for smooth operation. The valve opens and closes with very little pressure on the handle.
- Ball is diamond turned, after molding, to make it spherically perfect, which provides precise contact between ball and seats.
- PTFE self-lubricating stem bushings and seats cannot stick or bind.
- Stainless steel bolts.



MVSF300

MVSF300FP



MVSMT300

MVS300CF



MVS300CFFP

### 3" MANIFOLD STUBBY VALVES

PART NO	DESCRIPTION	MAX PSI	PIPE SIZE	OPENING THRU BALL	LOT QTY	REPLACEMENT HANDLE	REPAIR KIT
MVSF300	3" STANDARD PORT MANIFOLD VALVE FLANGE X MALE ADAPTER	100	3"	2½"	6/BOX	V25153	VS30200
MVSF300FP	3" FULL PORT MANIFOLD VALVE FLANGE X MALE ADAPTER	100	3"	3"	6/BOX	V25153	VS35200
MVSMT300	3" STANDARD PORT MANIFOLD VALVE FLANGE X MALE NPT	225	3"	2½"	4	V25153	VS30200
MVS300CF	3" STANDARD PORT MANIFOLD VALVE FLANGE X FLANGE	200	3"	2½"	6/BOX	V25153	VS30200
MVS300CFFP	3" FULL PORT MANIFOLD VALVE FLANGE X FLANGE	150	3"	3"	6/BOX	V25153	VS35200

# MANIFOLD FLANGE CONNECTIONS

## 3" FP STUBBY VALVES WITH STAINLESS STEEL

### FEATURES

- Precision molded polypropylene is reinforced with fiberglass for additional strength.
- Self-aligning ball moves freely against the PTFE seats for smooth operation. The valve opens and closes with very little pressure on the handle.
- Ball is diamond turned, after molding, to make it spherically perfect, which provides precise contact between ball and seats.
- Stainless steel bolts
- Compact design
- FKM seals



MVS300HSFP



MVSMT300HSFP

3" FULL PORT MANIFOLD STUBBY VALVES WITH SS						
PART NO	DESCRIPTION	MAX PSI	PIPE SIZE	OPENING THRU BALL	QTY	REPLACEMENT HANDLE
MVS300HSFP	3" FULL PORT MANIFOLD STUBBY VALVE FLANGE X FLANGE WITH SS BALL, STEM & HANDLE	100	3"	3"	1	VS30153SS
MVSMT300HSFP	3" FULL PORT MANIFOLD STUBBY VALVE MALE NPT X FLANGE WITH SS BALL, STEM & HANDLE	200	3"	3"	1	VS30153SS

# MANIFOLD FLANGE CONNECTIONS

## 3 WAY BOTTOM LOAD BALL VALVES

### FEATURES

- Stainless steel bolts
- Precision molded in fiberglass reinforced polypropylene for additional strength
- Self-aligning ball moves freely against the PTFE seats for smooth operation
- Ball is diamond turned after molding to make it spherically perfect, which provides precise contact between ball and seats
- PTFE self-lubricating stem bushings and seats
- FKM body seals
- Directional flow, right or left. Valve can be turned off to stop flow

### REPAIR KIT INCLUDES:

- Ball
- Body gasket
- Thrust washer
- Ball seats
- Upper stem bushing
- Stem o-ring



### 3 WAY BOTTOM LOAD MANIFOLD VALVES

PART NO	DESCRIPTION	MAX PSI	PIPE SIZE	OPENING THRU BALL	LOT QTY	HANDLE TYPE	REPLACEMENT HANDLE	REPAIR KIT
MV100BL	1" FP 3-WAY BOTTOM LOAD MANIFOLD VALVE	300	1"	1"	6	T	V10353TB	N/A
MV200BL	2" SP 3-WAY BOTTOM LOAD MANIFOLD VALVE	225	2"	1½"	6	T	V20353TB	V15200BL
MV220BL	2" FP 3-WAY BOTTOM LOAD MANIFOLD VALVE	150	2"	2"	8/BOX	STRAIGHT	V25353B	V25200BL
MV300BL	3" FP 3-WAY BOTTOM LOAD MANIFOLD VALVE	150	3"	3"	4/BOX	STRAIGHT	V25353B	V35200BL

## 3 WAY SIDE LOAD BALL VALVES

### FEATURES

- Stainless steel bolts
- Precision molded in fiberglass reinforced polypropylene for additional strength
- Self-aligning ball moves freely against the PTFE seats for smooth operation
- Ball is diamond turned after molding to make it spherically perfect, which provides precise contact between ball and seats
- PTFE self-lubricating stem bushings and seats
- FKM body seals
- Directional flow, right or left. Valve cannot be turned off to stop flow



### 3 WAY SIDE LOAD MANIFOLD VALVES

PART NO	DESCRIPTION	MAX PSI	PIPE SIZE	OPENING THRU BALL	LOT QTY	HANDLE TYPE	REPLACEMENT HANDLE	REPAIR KIT
MV100SL	1" FP 3-WAY SIDE LOAD MANIFOLD VALVE	300	1"	1"	6	T	V10353TB	N/A
MV200SL	2" SP 3-WAY SIDE LOAD MANIFOLD VALVE	225	2"	1½"	5	STRAIGHT	V20153SH	V15200BL
MV220SL	2" FP 3-WAY SIDE LOAD FULL PORT MANIFOLD VALVE - NEW INCREASED MAX PSI	120	2"	2"	8/BOX	STRAIGHT	V25153SH	V25200BL

# MANIFOLD FLANGE CONNECTIONS



## MANIFOLD PRESSURE SPIKE VALVES

PART NO	DESCRIPTION	CRACKING PRESSURE	MAX PSI	QTY
MPRV100-050	1" X 1" MANIFOLD PRESSURE SPIKE VALVE	50	300	1
MPRV100-075	1" X 1" MANIFOLD PRESSURE SPIKE VALVE	75	300	1
MPRV100-100	1" X 1" MANIFOLD PRESSURE SPIKE VALVE	100	300	1
MPRV100-125	1" X 1" MANIFOLD PRESSURE SPIKE VALVE	125	300	1

## PRESSURE SPIKE VALVES

### FEATURES

- FKM seals.
- Precision molded polypropylene is reinforced with fiberglass for additional strength.
- 360° orientation
- Preset pressure spring



## MANIFOLD DRY DISCONNECTS

PART NO	DESCRIPTION	MAX PSI	PIPE SIZE	OPENING THRU BALL	QTY	REPLACEMENT HANDLE	REPAIR KIT
DM200ACF	2" MALE MANIFOLD DRY-MATE WITH FKM SEALS	100	2"	1½"	1	DM20153M	DM20200A
DM200DCF	2" FEMALE MANIFOLD DRY-MATE WITH FKM SEALS	100	2"	1½"	1	DM20153F	DM20200D
DM300ACF	3" MALE MANIFOLD DRY-MATE WITH FKM SEALS	150	3"	3"	1	DM35153M	DM35200
DM300DCF	3" FEMALE MANIFOLD DRY-MATE WITH FKM SEALS	150	3"	3"	1	DM35153F	DM35200

**Note:** Male and female sold separately

## DRY-MATE™ DRY-DISCONNECTS

### FEATURES

- Easy to use
- Minimal fluid spillage
- Reduces risk of exposure
- Wide range of chemical resistance
- When properly installed and operated, the assembly will not accidentally separate while fluid is flowing; preventing costly mishaps.
- Spillage data: 2"=4ml, 3"=15ml

### REPAIR KIT INCLUDES:

- Face seal
- Ball
- Seats
- Body gasket
- Thrust bearings
- Stem bushings

# MANIFOLD FLANGE CONNECTIONS

## BOOM NOZZLE PIPE ADAPTER

### FEATURES

- Eliminates having to thread pipe
- Quick and easy assembly
- No welding necessary
- 360° orientation



M100PA



M100PAC



M100PAT

### BOOM NOZZLE PIPE ADAPTER

PART NO	DESCRIPTION	MAX PSI	LOT QTY
M100PA	1" FLANGED PIPE ADAPTER	300	10
M100PAC	1" FLANGED PIPE ADAPTER CAP	300	1
M100PAT	1" FLANGED PIPE ADAPTER TEE	300	1

## INDUCTORS

### FEATURES

- Threaded or manifold ends
- Glass reinforced polypropylene
- Designed for use with a volume pump. Typical volumes (80-240 US GPM) and pressures (26-52 PSI) should be used to operate the inductor.



HV200



MHV220A

### MANIFOLD INDUCTORS

PART NO	DESCRIPTION	PRESSURE AT PUMP	VOLUME DRAW	OPENING SIZE	LOT QTY
HV200	2" MPT INDUCTOR	225	49 GPM	7/16"	1
MHV200	2" MANIFOLD INDUCTOR WITH 1/2" PORT	300	37 GPM	5/16"	1
MHV220A	2" FULL PORT MANIFOLD INDUCTOR	225	49 GPM	9/16"	5

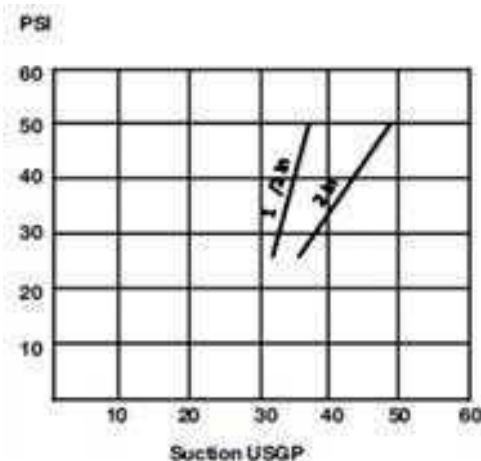

**Note:** The inductor is designed for use with a volume pump. Typical volumes and pressures used to operate the venturi would be in the 80 to 240 US GPM range at pressures from 26 to 52 PSI.

# MANIFOLD FLANGE CONNECTIONS

## INDUCTOR SYSTEMS

### FEATURES

- Installed after pump; suction completely empties inductor tank
- Keeps pump free of chemicals
- Easy assembly/installation with manifold connections found on pages 41-47.
- Choose your connections and valve
- Tank for illustration purposes only, not included



### MANIFOLD INDUCTOR SYSTEMS

PART NO	DESCRIPTION	MAX PSI	QTY
MIS220	2" FULL PORT MANIFOLD INDUCTOR SYSTEM FLANGE X FLANGE ASSEMBLED	225	1
MIS300	3" FULL PORT MANIFOLD INDUCTOR SYSTEM FLANGE X FLANGE ASSEMBLED	150	1

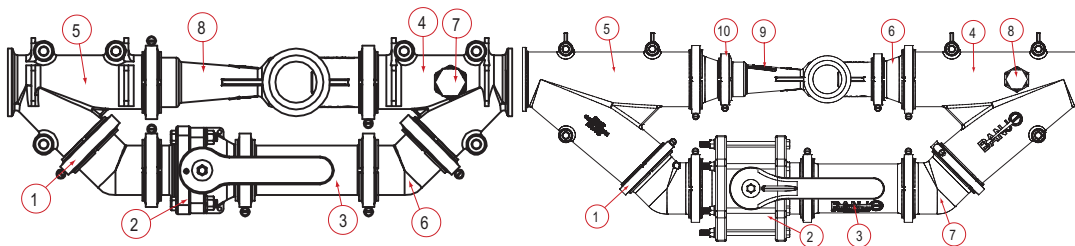

### MANIFOLD INDUCTORS

ITEM	PART NO	DESCRIPTION	LOT QTY
1	FC220	220 SERIES WORM SCREW CLAMP	10/BAG
2	MVS220CF	2" FP FLANGE X 2" FP FLANGE	9
3	M220CPG6	2" X 2" FULL PORT FLANGE X 6"	5
4	M220YG45	2" FULL PORT 45° Y FLANGE W/ 3/4" GAUGE PORT*	1
5	M220Y45	2" FULL PORT 45° Y FLANGE	5
6	M220CPG45	2" FULL PORT 45° COUPLING	10/BAG
7	PLUG075	3/4" PIPE PLUG	10/BAG
8	MHV220A	2" FULL PORT POLY VENTURI	5
N/S	M221G	2" FULL PORT EPDM MANIFOLD GASKET WITH RIB	30

### MANIFOLD INDUCTORS

ITEM	PART NO	DESCRIPTION	LOT QTY
1	FC300	300 SERIES WORM SCREW CLAMP	10/BAG
2	MV301CF	3" FP FLANGE X 3" FP FLANGE	1
3	M300CPG7	3" X 3" FULL PORT FLANGE X 7"	1
4	M300YG45	3" FULL PORT 45° Y FLANGE W/ 3/4" GAUGE PORT*	1
5	M300Y45	3" FULL PORT 45° Y FLANGE	1
6	M300220CPG	3" X 2" FULL PORT REDUCER FLANGE	1
7	M300CPG45	3" FULL PORT 45° COUPLING	1
8	PLUG075	3/4" PIPE PLUG	10/BAG
9	MHV220A	2" FULL PORT POLY VENTURI	5
10	FC220	220 SERIES WORM SCREW CLAMP	10/BAG
N/S	M221G	2" FULL PORT EPDM MANIFOLD GASKET WITH RIB	30
N/S	M301G	3" EPDM MANIFOLD GASKET WITH RIB	50

# MANIFOLD FLANGE CONNECTIONS

## FLOW METERS

### FEATURES

- Displays overall total volume and batch total volume
- Flow rate allows for Gallons or Liters per minute
- The display reads 6 digits for rate, 8 digits for total and 1 decimal place reading in tenths
- Magnetic style meter with stainless steel electrodes
- Self calibrating meter
- Measures water and most conductive liquids
- Flow meters will not read petroleum based liquids
- Easy to change six (6) AA batteries
- No moving parts to fail during use
- Glass-reinforced polypropylene
- Temperature range from 0°F to 150°F
- ±1% of reading (between 10% and 100% of maximum flow)
- ±3% of reading (between cutoff and 10% of maximum flow)
- There are 3 photoeyes located on the face of the flow meter. These are not push buttons; to activate you must hold your finger over the photoeye for 2-4 seconds
- It is recommended to have at least 10X the diameter of straight pipe before and after the flow meter



MFM100



MFM220



MFM300

### FLOW METERS

PART NO	DESCRIPTION	MAX PSI	GPM	QTY
MFM100	1" FULL PORT MANIFOLD FLOW METER	200	110 GPM	1
MFM220	2" FULL PORT MANIFOLD FLOW METER	200	300 GPM	1
MFM300	3" FULL PORT FLOW METER	200	670 GPM	1

# MANIFOLD FLANGE CONNECTIONS



## SWEEPS

### FEATURES

- Direct replacement for standard 90° flanged couplings
- Positive seals
- Quick and easy assembly
- Easy on/off hose connections
- 360° orientation
- Improved flow for max GPM

## SWEEPS

PART NO	DESCRIPTION	MAX PSI	LOT QTY
M100125BRBSWP90	1" FLANGE X 1/4" HOSE BARB SWEEP	300	10/BAG
M100BRBSWP90	1" FLANGE X HOSE BARB SWEEP	300	10/BAG
M100BRBSWPG90	1" FULL PORT FLANGE X 1" HOSE BARB SWEEP W/ 1/4" GAUGE PORT	300	10/BAG
M100SWP90	1" FLANGE X FLANGE SWEEP	300	10/BAG
M100SWPG90	1" FLANGE X FLANGE SWEEP W/ 1/4" GAUGE PORT	300	10/BAG
M200SWP90	2" FLANGE X FLANGE SWEEP	300	10/BAG
M200150BRBSWP90	2" FLANGE X 1/2" HOSE BARB SWEEP	300	10/BAG
M220200SWP90	2" FULL PORT FLANGE X 2" FLANGE SWEEP	225	10/BAG
M220ASWP90	2" FULL PORT FLANGE X MALE ADAPTER SWEEP	200	10/BAG
M220BRBSWP90	2" FULL PORT FLANGE X HOSE BARB SWEEP	225	10
M220MPTSWP90	2" FULL PORT FLANGE X MALE NPT THREAD SWEEP	300	1
M220SWP90	2" FULL PORT FLANGE X FLANGE SWEEP	250	10/BAG
M220SWPG90	2" FULL PORT FLANGE X FLANGE SWEEP W/ 1/4" GAUGE PORT	250	1
M221SWP90	2" FULL PORT MANIFOLD 90° SWEEP	225	1
M300ASWP90	3" FLANGE X MALE ADAPTER SWEEP	100	1
M300BRBSWP90	3" FLANGE X HOSE BARB SWEEP	225	1
M300BRBSWPG90	3" FLANGE X HOSE BARB SWEEP W/ 1/4" GAUGE PORT	225	1
M300MPTSWP90	3" FLANGE X MALE NPT THREAD SWEEP	200	1
M300SWP90	3" FLANGE X FLANGE SWEEP	200	1
M300SWPG90	3" FLANGE X FLANGE SWEEP W/ 1/4" GAUGE PORT	200	1
M300220SWP90	3" FULL PORT FLANGE X 2" FULL PORT FLANGE SWEEP	200	1

# MANIFOLD FLANGE CONNECTIONS

## FITTINGS

## FEATURES

- Quick and easy assembly
- Positive seals
- Easy on/off hose connections
- 360° orientation
- Parts must be ordered in lot quantities.



## SWIVEL

PART NO	DESCRIPTION	MAX PSI	QTY
MSW220	2" FULL PORT MANIFOLD FLANGE SWIVEL	200	1

## CHECK VALVES

PART NO	DESCRIPTION	CRACKING PRESSURE PSI	MAX PSI	LOT QTY
MCV100	1" FLANGED CHECK VALVE	1	300	10
MCV200	2" FLANGED CHECK VALVE	0.5	300	10
MCV100V	1" MANIFOLD CHECK VALVE	1	300	1
MCV221	2" FULL PORT FLANGED CHECK VALVE	>0.5	200	10
MCV300	3" FLANGED CHECK VALVE W/5 LB SPRING	1.5	200	1
MCV301	3" FLANGED CHECK VALVE W/½ LB SPRING	>0.5	N/A	1

## PVC GLUE SOCKET

PART NO	DESCRIPTION	MAX PSI	LOT QTY
M101GSA	1" FULL PORT FLANGE X 1" PVC GLUE SOCKET FITTING	300	10
M221GSA	2" FULL PORT FLANGE X 2" PVC GLUE SOCKET FITTING	300	10
M301GSA	3" FULL PORT FLANGE X 3" PVC GLUE SOCKET FITTING	300	1

## 316 SS SOCKET WELD

PART NO	DESCRIPTION	MAX PSI	LOT QTY
M100SWFSS	1" FLANGE X 1" SOCKET WELD FITTING	300	10
M200SWFSS	2" FLANGE X 2" SOCKET WELD FITTING	300	1
M220SWFSS	2" FULL PORT FLANGE X 2" SOCKET WELD FITTING	300	10
M220375SWFSS	2" FULL PORT FLANGE X 2" SOCKET WELD FITTING X 3/4"	300	1
M300SWFSS	3" FLANGE X 3" SOCKET WELD FITTING	300	1
M300375SWFSS	3" FLANGE X 3" SOCKET WELD FITTING X 3/4"	300	1

## COUPLINGS

PART NO	DESCRIPTION	MAX PSI	LOT QTY
M100CPG	1"MANIFOLD COUPLING 2¼" LONG	300	10/BAG
M100CPG025G	1" MANIFOLD COUPLING 2 1/4" PORT	300	10/BAG
M101CPG	1"MANIFOLD COUPLING 2 ¼" LONG W/ BLIND GAUGE PORT	300	10/BAG
M200CPG	2" MANIFOLD COUPLING 4½" LONG	300	10/BAG
M200CPG025G	2" MANIFOLD COUPLING 4 1/2" LONG W/ ¼" PORT	300	10/BAG
M200CPG038G	2" MANIFOLD COUPLING 4 1/2" LONG W/ 3/8" PORT	300	10/BAG
M201CPG	2" MANIFOLD COUPLING 4 1/2" LONG W/ BLIND GAUGE PORT	300	10/BAG
M220CPG	2" FULL PORT MANIFOLD COUPLING 2 31/32 " LONG	300	10/BAG
M220CPG2GISO	2" FULL PORT MANIFOLD COUPLING 2" LONG W/ G¼ PORT	300	10/BAG
M220CPG3G	2" FULL PORT MANIFOLD COUPLING 3" LONG W/ 1/2" PORTS (3)	225	10/BAG
M220CPG6	2" FULL PORT MANIFOLD COUPLING 6" LONG	300	5
M220CPG6025G	2" FULL PORT MANIFOLD COUPLING 6" LONG W/ ¼" PORTS	300	10/BAG
M221CPG	2" FP MANIFOLD COUPLING 3" LONG W/ 3 BLIND GAUGE PORTS	300	1
M221CPG6	2" FP MANIFOLD COUPLING 6" LONG W/ BLIND GAUGE PORT	300	10/BAG
M300CPG	3" FULL PORT MANIFOLD COUPLING 4" LONG	200	1
M300CPG2	3" FP MANIFOLD COUPLING 4" LONG W/ BLIND GAUGE PORT	200	1
M300CPG7	3" FULL PORT MANIFOLD COUPLING 7" LONG	150	1
M300CPG12G	3" FP MANIFOLD COUPLING 12" LONG W/ 1/2" GAUGE PORT	150	1
M300CPG55	3" MANIFOLD COUPLING 5.5" LONG	150	1
M300CPG55G	3" FULL PORT MANIFOLD COUPLING 5.5" LONG W/ ¼" PORT	150	1
M300CPG7025G	3" MANIFOLD COUPLING 7 " LONG W/ ¼" PORT	300	1
M300CPG2GISO	3" MANIFOLD COUPLING 2" LONG W/ G¼ GAUGE PORT	300	1
M301CPG7	3" MANIFOLD COUPLING 7" LONG	150	1

# MANIFOLD FLANGE CONNECTIONS



## 45° COUPLINGS

PART NO	DESCRIPTION	MAX PSI	LOT QTY
M100CPG45	1" X 1" 45° FLANGE	300	10/BAG
M200CPG45	2" X 2" 45° FLANGE	300	10/BAG
M220CPG45	2" X 2" FULL PORT 45° FLANGE	225	10/BAG
M300CPG45	3" X 3" FULL PORT 45° FLANGE	225	1

## 90° COUPLINGS

PART NO	DESCRIPTION	MAX PSI	LOT QTY
M100CPG90	1" X 1" 90° FLANGE	300	10/BAG
M200CPG90	2" X 2" 90° FLANGE	300	10/BAG
M200CPG90SH	2" X 2" 90° SHORT FLANGE	300	10/BAG
M220CPG90	2" X 2" 90° FULL PORT FLANGE	200	10/BAG
M300CPG90	3" X 3" 90° FULL PORT FLANGE	200	1

## 45° Y FLANGED COUPLINGS

PART NO	DESCRIPTION	MAX PSI	LOT QTY
M200YG45	2" 45° Y FLANGE W/ 1/4" GAUGE PORT	225	1
M220Y45	2" FULL PORT 45° Y FLANGE	300	5
M220YG45	2" FULL PORT 45° Y FLANGE W/ 1/4" GAUGE PORT	225	1
M300Y45	3" FULL PORT 45° Y FLANGE	200	1
M300YG45	3" FULL PORT 45° Y FLANGE W/ 1/4" GAUGE PORT	200	1
M300ELB90	M300 3 WAY CORNER ELBOW		1

## 3" MANIFOLD WYE

PART NO	DESCRIPTION	MAX PSI	QTY
M300220WYCG	M300 X M220 X M220 X M220 FULL PORT FLANGE WYE W/ 1/4" GAUGE PORT	300	1

## REDUCER COUPLINGS

PART NO	DESCRIPTION	MAX PSI	LOT QTY
M200100CPG	2" X 1" REDUCER FLANGE	300	10/BAG
M220100CPG	2" FULL PORT X 1" REDUCER FLANGE	225	10/BAG
M220200CPG	2" FULL PORT X 2" REDUCER FLANGE	225	10/BAG
M300200CPG	3" X 2" REDUCER FLANGE	225	1
M300220CPG	3" X 2" FULL PORT REDUCER FLANGE	225	1

## TEES

PART NO	DESCRIPTION	MAX PSI	LOT QTY
M100TEE	1" FLANGED TEE	300	10/BAG
M101TEE	1" FLANGED TEE LONG	300	10
M200100TEE	2" X 1" FLANGED TEE	300	10
M200TEE	2" FLANGED TEE	200	10/BAG
M220100TEE	2" FULL PORT FLANGED TEE X 1" FLANGED TEE	225	10
M220200TEE	2" FULL PORT FLANGED TEE X 2" FLANGED TEE	300	10
M220TEE	2" FULL PORT FLANGED TEE	225	10
M300TEE	3" FLANGED TEE	150	1

## U BOLTS

PART NO	DESCRIPTION	MAX PSI	LOT QTY
UB100	100 SERIES MOUNTING U BOLT	N/A	1
UB202	202 SERIES MOUNTING U BOLT	N/A	10
UB220	220 SERIES MOUNTING U BOLT	N/A	10

## FITTINGS

### FEATURES

- Quick and easy assembly
- Positive seals
- Easy on/off hose connections
- 360° orientation
- Parts must be ordered in lot quantities.

# MANIFOLD FLANGE CONNECTIONS

## FITTINGS

### FEATURES

- Quick and easy assembly
- Positive seals
- Easy on/off hose connections
- 360° orientation
- Parts must be ordered in lot quantities.



### SS BUTT WELD ADAPTER

PART NO	DESCRIPTION	MAX PSI	QTY
M220BWASS	2" FULL PORT STAINLESS STEEL BUTT WELD ADAPTER	300	1



### FEMALE NPT THREAD

PART NO	DESCRIPTION	MAX PSI	LOT QTY
M100050FPT	1" FLANGE X 1/2" FEMALE THREAD	300	10/BAG
M100075FPT	1" FLANGE X 3/4" FEMALE THREAD	300	10/BAG
M100FPT	1" FLANGE X 1" FEMALE THREAD	300	10/BAG
M200FPT	2" FLANGE X 2" FEMALE THREAD	300	10/BAG
M200150FPT	2" FLANGE X 1 1/2" FEMALE THREAD	300	10/BAG
M220FPT	2" FULL PORT FLANGE X 2" FEMALE THREAD	300	10/BAG
M300FPT	3" FLANGE X 3" FEMALE THREAD	200	1



### MALE THREAD

PART NO	DESCRIPTION	MAX PSI	LOT QTY
M100075MPT	1" FLANGE X 3/4" MALE THREAD	300	10/BAG
M100MPT	1" FLANGE X 1" MALE THREAD	300	10/BAG
M100125MPT	1" FLANGE X 1 1/4" MALE THREAD	300	10/BAG
M200125MPT	2" FLANGE X 1 1/4" MALE THREAD	300	10/BAG
M200150MPT	2" FLANGE X 1 1/2" MALE THREAD	300	10/BAG
M200MPT	2" FLANGE X 2" MALE THREAD	300	10/BAG
M220MPT	2" FULL PORT FLANGE X 2" MALE THREAD	300	10/BAG
M300MPT	3" FLANGE X 3" MALE THREAD	300	1



### 316 SS MALE THREAD

PART NO	DESCRIPTION	MAX PSI	QTY
M100MPTSS	1" FLANGE X 1" MALE THREAD	300	1
M200125MPTSS	2" FLANGE X 1 1/4" MALE THREAD	300	1
M200150MPTSS	2" FLANGE X 1 1/2" MALE THREAD	300	1
M200MPTSS	2" FLANGE X 2" MALE THREAD	300	1
M220150MPTSS	2" FULL PORT FLANGE X 1 1/2" MALE THREAD	300	1
M220MPTSS	2" FULL PORT FLANGE X 2" MALE THREAD	300	1
M300220MPTSS	3" FLANGE X 2" FULL PORT MALE THREAD	300	1
M300MPTSS	3" FLANGE X 3" MALE THREAD	300	1

# MANIFOLD FLANGE CONNECTIONS

## FITTINGS

### FEATURES

- Quick and easy assembly
- Positive seals
- Easy on/off hose connections
- 360° orientation
- Parts must be ordered in lot quantities.



### PLUGS

PART NO	DESCRIPTION	MAX PSI	LOT QTY
M100PLG	1" FLANGE PLUG	300	10/BAG
M200PLG	2" FLANGE PLUG	300	10/BAG
M220PLG	2" FULL PORT FLANGE PLUG	300	10/BAG
M300PLG	3" FULL PORT FLANGE PLUG	225	10/BAG
M100PLG025	1" FLANGE PLUG WITH 1/4" FPT	300	10/BAG
M100PLG050	1" FLANGE PLUG WITH 1/2" FPT	300	10/BAG
M200PLG025	2" FLANGE PLUG WITH 1/4" FPT	225	10/BAG
M200PLG038	2" FLANGE PLUG WITH 3/8" FPT	300	10/BAG
M200PLG050	2" FLANGE PLUG WITH 1/2" FPT	225	10/BAG
M200PLG075	2" FLANGE PLUG WITH 3/4" FPT	225	10/BAG
M200PLG100	2" FLANGE PLUG WITH 1" FPT	225	10/BAG
M220PLG038	2" FULL PORT FLANGE PLUG WITH 3/8" FPT	150	10/BAG
M220PLG075	2" FULL PORT FLANGE PLUG WITH 3/4" FPT	225	10/BAG
M300PLG075	3" FLANGE PLUG WITH 3/4" FPT	200	1
M300PLG100	3" FLANGE PLUG WITH 1" FPT	200	1

### FEMALE COUPLER

PART NO	DESCRIPTION	MAX PSI	LOT QTY
M220D	2" FULL PORT FLANGE X 2" FEMALE COUPLER	225	20
M303D	3" FULL PORT FLANGE X 3" FEMALE COUPLER WITH 3 ARMS	225	10

### MALE ADAPTER

PART NO	DESCRIPTION	MAX PSI	LOT QTY
M100A	1" FLANGE X 1" MALE ADAPTER	300	10/BAG
M200A	2" FLANGE X 2" MALE ADAPTER	300	10/BAG
M220A	2" FULL PORT FLANGE X 2" MALE ADAPTER	225	10/BAG
M300A	3" FULL PORT FLANGE X 3" MALE ADAPTER	75	1
M300400A	3" MANIFOLD FLANGE X 4" MALE COUPLER	75	1

### CROSS

PART NO	DESCRIPTION	MAX PSI	LOT QTY
M100CR	1" FLANGED CROSS	300	10/BAG
M200CR	2" FLANGED CROSS	300	10
M220CR	2" FULL PORT FLANGED CROSS	200	10
M300CR	3" FLANGED CROSS	125	1

# MANIFOLD FLANGE CONNECTIONS

## FITTINGS

### FEATURES

- Quick and easy assembly
- Positive seals
- Easy on/off hose connections
- 360° orientation
- Parts must be ordered in lot quantities.



### HOSE BARB

PART NO	DESCRIPTION	MAX PSI	LOT QTY
M100075BRB	1" FLANGE X 3/4" HOSE BARB	300	10/BAG
M100BRB	1" FLANGE X 1" HOSE BARB	300	10/BAG
M100125BRB	1" FLANGE X 1 1/4" HOSE BARB	300	10/BAG
M200100BRB	2" FLANGE X 1" HOSE BARB	300	10/BAG
M200125BRB	2" FLANGE X 1 1/4" HOSE BARB	300	10/BAG
M200150BRB	2" FLANGE X 1 1/2" HOSE BARB	300	10/BAG
M200BRB	2" FLANGE X 2" HOSE BARB	300	10/BAG
M220100BRB	2" FULL PORT FLANGE X 1" HOSE BARB	300	10/BAG
M220125BRB	2" FULL PORT FLANGE X 1 1/4" HOSE BARB	300	10/BAG
M220150BRB	2" FULL PORT FLANGE X 1 1/2" HOSE BARB	300	10/BAG
M220BRB	2" FULL PORT FLANGE X 2" HOSE BARB	300	10/BAG
M300220BRB	3" FLANGE X 2" FULL PORT HOSE BARB	125	1
M300400BRB	3" FLANGE X 4" HOSE BARB	150	1
M300BRB	3" FLANGE X 3" HOSE BARB	200	1

### 90° HOSE BARB ELBOW

PART NO	DESCRIPTION	MAX PSI	LOT QTY
M100075BRB90	1" FLANGE X 3/4" 90° HOSE BARB	300	10/BAG
M100BRB90	1" FLANGE X 1" 90° HOSE BARB	300	10/BAG
M100125BRB90	1" FLANGE X 1 1/4" 90° HOSE BARB	300	10/BAG
M100150BRB90	1" FLANGE X 1 1/2" 90° HOSE BARB	300	10/BAG
M200100BRB90	2" FLANGE X 1" 90° HOSE BARB	300	10/BAG
M200125BRB90	2" FLANGE X 1 1/4" 90° HOSE BARB	300	10/BAG
M200150BRB90	2" FLANGE X 1 1/2" 90° HOSE BARB	300	10/BAG
M200BRB90	2" FLANGE X 2" 90° HOSE BARB	300	10/BAG
M220150BRB90	2" FULL PORT FLANGE X 1 1/2" 90° HOSE BARB	300	10/BAG
M220BRB90	2" FULL PORT FLANGE X 2" 90° HOSE BARB	300	10/BAG
M300220BRB90	3" FLANGE X 2" 90° FULL PORT HOSE BARB	300	1
M300BRB90	3" FLANGE X 3" 90° HOSE BARB	150	1

### 45° HOSE BARB ELBOW

PART NO	DESCRIPTION	MAX PSI	LOT QTY
M100075BRB45	1" FLANGE X 1" 45° HOSE BARB ELBOW	300	10/BAG
M100BRB45	1" FLANGE X 1" 45° HOSE BARB ELBOW	300	10/BAG
M200BRB45	2" FLANGE X 2" 45° HOSE BARB ELBOW	300	10/BAG
M200125BRB45	2" FLANGE X 1 1/4" 45° HOSE BARB ELBOW	300	10/BAG
M200150BRB45	2" FLANGE X 1 1/2" 45° HOSE BARB ELBOW	300	10/BAG
M220BRB45	2" FULL PORT FLANGE X 2" 45° HOSE BARB ELBOW	300	10/BAG
M300BRB45	3" FLANGE X 3" 45° HOSE BARB ELBOW	150	1

### HOSE BARB TEE

PART NO	DESCRIPTION	MAX PSI	LOT QTY
M100050HBT	1" FLANGE X 1/2" HOSE BARB TEE	N/A	10/BAG
M100075HBT	1" FLANGE X 3/4" HOSE BARB TEE	N/A	10/BAG
M100100HBT	1" FLANGE X 1" HOSE BARB TEE	300	10/BAG
M100125HBT	1" FLANGE X 1 1/4" HOSE BARB TEE	300	10/BAG
M220150HBT	2" FULL PORT FLANGE X 1 1/2" HOSE BARB TEE	300	10/BAG
M220200HBT	2" FULL PORT FLANGE X 2" HOSE BARB TEE	300	10/BAG
M300300HBT	3" FLANGE X 3" HOSE BARB TEE	150	1

# MANIFOLD FLANGE CONNECTIONS



Rib keeps gasket in place during assembly.



M302G



M201G



200G



200GV



## BOLTED FLANGE CLAMPS

PART NO	DESCRIPTION	TORQUE	QTY
FC220B	2" FULL PORT BOLTED FLANGE CLAMP	150 IN/LBS	1
FC300B	3" BOLTED FLANGE CLAMP	150 IN/LBS	1

## T-BOLT FLANGE CLAMPS

PART NO	DESCRIPTION	TORQUE	QTY
FC220TB	2" FULL PORT HI-TORQUE T-BOLT FLANGE CLAMP	100 IN/LBS	10/BAG
FC300TB	3" FULL PORT HI-TORQUE T-BOLT FLANGE CLAMP	100 IN/LBS	1

## FLANGE CLAMPS

PART NO	DESCRIPTION	TORQUE	QTY
FC100	100 SERIES WORM SCREW CLAMP	50-60 IN/LBS	10/BAG
FC200	200 SERIES WORM SCREW CLAMP	90-100 IN/LBS	10/BAG
FC220	220 SERIES WORM SCREW CLAMP	90-100 IN/LBS	10/BAG
FC300	300 SERIES WORM SCREW CLAMP	90-100 IN/LBS	10/BAG

## GASKETS

PART NO	DESCRIPTION	GASKET MATERIAL	LOT QTY
M100G	100 SERIES MANIFOLD GASKET	EPDM	25
M101G	100 SERIES MANIFOLD GASKET WITH RIB	EPDM	35
M102G	1" & 1¼" SKIRTED FLANGE GASKET	EPDM	1
M100GV	100 SERIES GASKET	FKM	10
75GV	¾" FKM GASKET	FKM	10
150G	200 SERIES GASKET	EPDM	25
150GV	200 SERIES GASKET	FKM	10
200G	220 SERIES FULL PORT GASKET	EPDM	25
200GV	220 SERIES FULL PORT GASKET	FKM	10
M201G	200 SERIES MANIFOLD GASKET WITH RIB	EPDM	30
M202G	1½" SKIRTED FLANGE GASKET	EPDM	1
M221G	220 SERIES FULL PORT MANIFOLD GASKET WITH RIB	EPDM	30
M222G	2" SKIRTED FLANGE GASKET	EPDM	1
300G	300 SERIES GASKET	EPDM	25
300GV	300 SERIES GASKET	FKM	10
M301G	300 SERIES MANIFOLD GASKET WITH RIB	EPDM	50
M302G	3" SKIRTED FLANGE GASKET	EPDM	1

## MINI T STRAINERS

PART NO	DESCRIPTION	MAX PSI	QTY
MLSTM100-80	1" MANIFOLD MINI T STRAINER 80 MESH	300	1
MLSTM100HB	1" MANIFOLD MINI T STRAINER HEAD & BOWL	N/A	1
MLSTM100HBC	1" MANIFOLD MINI T STRAINER HEAD & CLEAR BOWL	N/A	1

## FITTINGS

### FEATURES

- Quick and easy assembly
- Positive seals
- Easy on/off hose connections
- 360° orientation
- Parts must be ordered in lot quantities.

## MINI T LINE STRAINERS

### FEATURES

- Heavy duty glass reinforced polypropylene
- Clear bowl made of polycarbonate
- EPDM gaskets standard

# MANIFOLD FLANGE CONNECTIONS

## 1"-2" T LINE STRAINERS

### FEATURES

- EPDM gaskets STD
- Poly ribbed 316 stainless steel screens
- FKM gasket options as noted "V" suffix

MOUNTING TUBES



MOUNTING TUBES



## 1"-2" Y LINE STRAINERS

### FEATURES

- EPDM gaskets
- Poly ribbed 316 stainless steel screens



## Y LINE STRAINERS

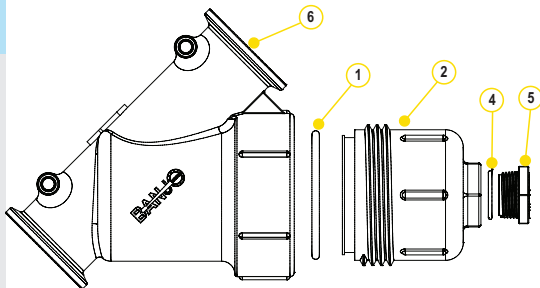

## 1" FULL PORT MANIFOLD T LINE STRAINERS WITH MOUNTING TUBES

PART NO	DESCRIPTION	MAX PSI	QTY
MLST100-30	1" MANIFOLD T STRAINER W/30 MESH SCREEN	300	1
MLST100-50	1" MANIFOLD T STRAINER W/50 MESH SCREEN	300	1
MLST100-80	1" MANIFOLD T STRAINER W/80 MESH SCREEN	300	1
MLST100-100	1" MANIFOLD T STRAINER W/100 MESH SCREEN	300	1
MLST100-80V	1" MANIFOLD T STRAINER W/ 80 MESH SCREEN WITH FKM GASKETS	300	1

## 2" STANDARD PORT MANIFOLD T LINE STRAINERS WITH MOUNTING TUBES

PART NO	DESCRIPTION	MAX PSI	QTY
MLST150-30	2" MANIFOLD T STRAINER W/30 MESH SCREEN	225	1
MLST150-50	2" MANIFOLD T STRAINER W/50 MESH SCREEN	225	1
MLST150-80	2" MANIFOLD T STRAINER W/80 MESH SCREEN	225	1
MLST150-80V	2" MANIFOLD T STRAINER W/80 MESH SCREEN WITH FKM GASKETS	225	1
MLST150-100	2" MANIFOLD T STRAINER W/100 MESH SCREEN	225	1

## 1" FULL PORT MANIFOLD Y LINE STRAINERS WITH MOUNTING TUBES

PART NO	DESCRIPTION	MAX PSI	QTY
MLS100-80	1" MANIFOLD Y STRAINER W/80 MESH SCREEN	225	1

## 2" STANDARD PORT MANIFOLD Y LINE STRAINERS WITH MOUNTING TUBES

PART NO	DESCRIPTION	MAX PSI	QTY
MLS200-20M	2" MANIFOLD Y STRAINER W/20 MESH SCREEN	225	1
MLS200-50M	2" MANIFOLD Y STRAINER W/50 MESH SCREEN	225	1
MLS200-80M	M200 Y STRAINER W/ MOUNT 80 MESH	225	1

## 2" STANDARD PORT MANIFOLD Y LINE STRAINERS

PART NO	DESCRIPTION	MAX PSI	QTY
MLS200-12	2" MANIFOLD Y STRAINER W/12 MESH SCREEN	225	1
MLS200-20	2" MANIFOLD Y STRAINER W/20 MESH SCREEN	225	1
MLS200-50	2" MANIFOLD Y STRAINER W/50 MESH SCREEN	225	1
MLS200-80	2" MANIFOLD Y STRAINER W/80 MESH SCREEN	225	1

## REPLACEMENT PARTS 2"

ITEM	PART NO	DESCRIPTION	QTY
1	LS150-G	2" EPDM GASKET	1
2	LS150-C	2" Y BOWL, DRAIN PLUG, O-RING	1
3	LSQ200-PL	2" PLUG	1
4	LSQ200-R	O-RING	1
5	LST225D	DECAL	1
6	MLS200BB	2" MANIFOLD Y STRAINER BODY	1
KIT	MLS200BCM	2" FLANGE Y STRAINER BODY & CAP	1

# MANIFOLD FLANGE CONNECTIONS

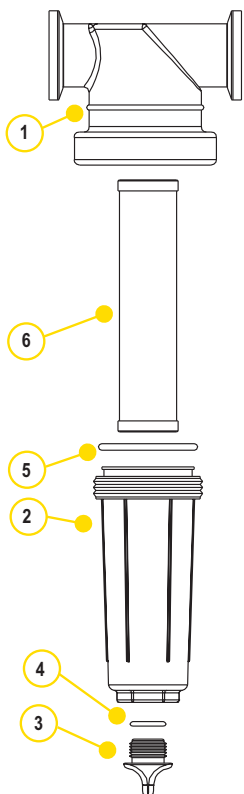

## REPLACEMENT PARTS 1"

ITEM	PART NO	DESCRIPTION	QTY
1	MLST100-H	1" T BODY	1
2	LST100-B	1" T BOWL, DRAIN PLUG, O-RING	1
3	12777	1/2" PLUG	1
4	UV15163	O-RING	1
5	LST100-G	1" EPDM GASKET	1
5	LST100-GV	1" FKM GASKET	1
6	LST116	16 MESH SCREEN	1
6	LST130	30 MESH SCREEN	1
6	LST150	50 MESH SCREEN	1
6	LST180	80 MESH SCREEN	1
6	LST1100	100 MESH SCREEN	1
KIT	MLST100-HB	KIT INCLUDES ITEMS 1-5	1

## REPLACEMENT PARTS 2"

ITEM	PART NO	DESCRIPTION	QTY
1	MLST150-H	1 1/2" T BODY	1
2	LST150-B	1 1/2" T BOWL, DRAIN PLUG, O-RING	1
3	LSQ200-PL	1 1/2" PLUG	1
4	LSQ200-R	O-RING	1
5	LST150-G	1 1/2" EPDM GASKET	1
5	LST150-GV	1 1/2" FKM GASKET	1
6	LST1516	16 MESH SCREEN	1
6	LST1530	30 MESH SCREEN	1
6	LST1550	50 MESH SCREEN	1
6	LST1580	80 MESH SCREEN	1
6	LST15100	100 MESH SCREEN	1
KIT	MLST150-HB	KIT INCLUDES ITEMS 1-5	1

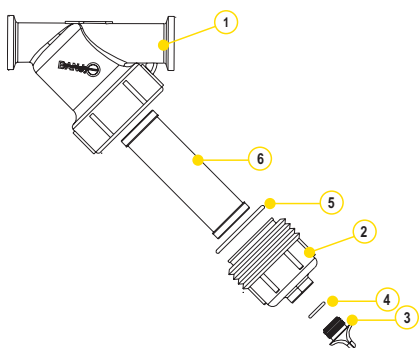

## REPLACEMENT PARTS 2"

ITEM	PART NO	DESCRIPTION	QTY
1	MLS200B	2" Y BODY	1
2	LS150-C	2" Y BOWL, DRAIN PLUG, O-RING	1
3	LSQ200-PL	2" PLUG	1
4	LSQ200-R	O-RING	1
5	LS150-G	2" EPDM GASKET	1
5	LS150-GV	2" FKM GASKET	1
6	LS206	6 MESH SCREEN	1
6	LS212	12 MESH SCREEN	1
6	LS220	20 MESH SCREEN	1
6	LS230	30 MESH SCREEN	1
6	LS250	50 MESH SCREEN	1
6	LS280	80 MESH SCREEN	1
6	LS2120	120 MESH SCREEN	1
KIT	MLS200BC	KIT INCLUDES ITEMS 1-5	1

## REPLACEMENT PARTS 1"

ITEM	PART NO	DESCRIPTION	QTY
1	MLS100B	1" Y BODY	1
2	LS100-C1	1" Y BOWL, DRAIN PLUG, O-RING	1
3	12777	1/2" PLUG	1
4	UV15163	O-RING	1
5	LS100-G	1" EPDM GASKET	1
6	LS120	20 MESH SCREEN	1
6	LS140	40 MESH SCREEN	1
6	LS180	80 MESH SCREEN	1
KIT	MLS100BC	KIT INCLUDES ITEMS 1-5	1

## T LINE STRAINERS

### SCREENS

MESH SIZE	RIB COLOR
16 MESH	BROWN RED
30 MESH	FLAME RED
50 MESH	GENTIAN BLUE
80 MESH	ZINC YELLOW
100 MESH	TRAFFIC GREEN

## Y LINE STRAINERS

### SCREENS

MESH SIZE	RIB COLOR
6 MESH	WHITE
12 MESH	BLACK
20 MESH	BEIGE
30 MESH	FLAME RED
40 MESH	BROWN
50 MESH	GENTIAN BLUE
80 MESH	ZINC YELLOW
100 MESH	TRAFFIC GREEN
120 MESH	BLACK

# MANIFOLD FLANGE CONNECTIONS

## 2" FULL PORT Y LINE STRAINERS

### FEATURES

- EPDM gaskets
- 316 stainless steel screens



### 2" FULL PORT MANIFOLD Y LINE STRAINERS

PART NO	DESCRIPTION	MAX PSI	QTY
MLS222-04	2" FULL PORT MANIFOLD Y STRAINER W/4 MESH SCREEN	225	1
MLS222-10	2" FULL PORT MANIFOLD Y STRAINER W/12 MESH SCREEN	225	1
MLS222-16	2" FULL PORT MANIFOLD Y STRAINER W/16 MESH SCREEN	225	1
MLS222-30	2" FULL PORT MANIFOLD Y STRAINER W/30 MESH SCREEN	225	1
MLS222-50	2" FULL PORT MANIFOLD Y STRAINER W/50 MESH SCREEN	225	1
MLS222-80	2" FULL PORT MANIFOLD Y STRAINER W/80 MESH SCREEN	225	1
MLS222-30V	2" FULL PORT MANIFOLD Y STRAINER W 30 MESH SCREEN	225	1

## 3" Y LINE STRAINERS

### FEATURES

- EPDM gaskets
- 304 stainless steel screens
- Must use on suction side or non-pressure side in all applications



### 3" FULL PORT MANIFOLD Y LINE STRAINERS

PART NO	DESCRIPTION	MAX PSI	LOT QTY
MLS300-12	3" MANIFOLD Y STRAINER W/12 MESH SCREEN	100	1
MLS300-20	3" MANIFOLD Y STRAINER W/20 MESH SCREEN	100	1
MLS300-50	3" MANIFOLD Y STRAINER W/50 MESH SCREEN	100	1
MLS300-20V	3" MANIFOLD Y STRAINER W/20 MESH SCREEN	100	1

# MANIFOLD FLANGE CONNECTIONS

## 2" FULL PORT Y LINE STRAINERS

### FEATURES

- EPDM gaskets
- 316 stainless steel screens

## 3" Y LINE STRAINERS

### FEATURES

- EPDM gaskets
- 304 stainless steel screens
- Must use on suction side or non-pressure side in all applications

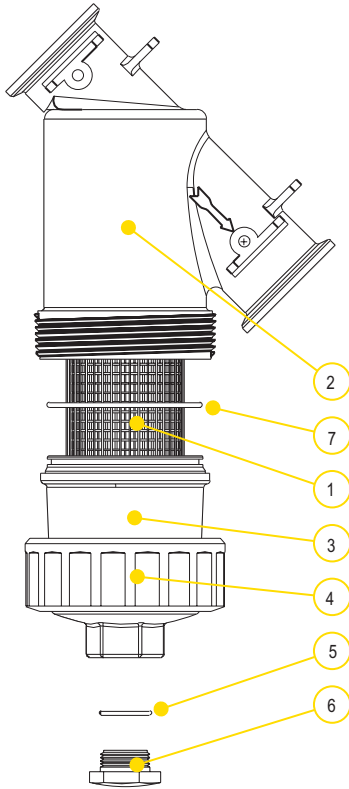

### REPLACEMENT PARTS 2"

ITEM	PART NO	DESCRIPTION	QTY
1	LST204SS	4 SS MESH SCREEN	1
1	LST206SS	6 SS MESH SCREEN	1
1	LST208SS	8 SS MESH SCREEN	1
1	LST210SS	10 SS MESH SCREEN	1
1	LST216SS	16 SS MESH SCREEN	1
1	LST230SS	30 SS MESH SCREEN	1
1	LST250SS	50 SS MESH SCREEN	1
1	MLS250SS	50 SS MESH PERFORATED SCREEN	1
1	LST280SS	80 SS MESH SCREEN	1
1	MLS280SS	80 SS MESH PERFORATED SCREEN	1
1	LST2100SS	100 SS MESH SCREEN	1
1	MLS2100SS	100 SS MESH PERFORATED SCREEN	1
2	MLS222B	2" FLANGED Y STRAINER BODY	1
3	MLS220C1	2" FLANGED Y STRAINER CAP	1
4	MLS220R1	2" FLANGED Y STRAINER RING	1
5	LSQ200-R	2" PLUG GASKET	1
6	LSQ200-PL	2" PLUG	1
7	MLS220G1	2" BODY GASKET	1
2-7	MLS222BC	STRAINER WITHOUT SCREEN	1

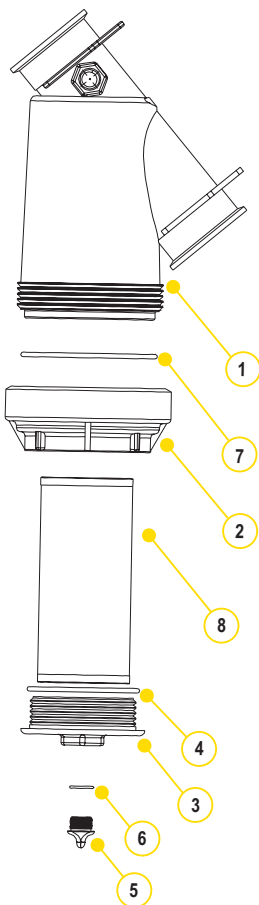

### REPLACEMENT PARTS 3"

ITEM	PART NO	DESCRIPTION	QTY
1	MLS300B	3" FLANGED Y STRAINER BODY	1
2	MLS300CAP	3" FLANGED Y STRAINER CAP	1
3	LS300EC	3" END CAP	1
4	MLS300ECG	3" EPDM END CAP GASKET	1
4	MLS300ECGV	3" FKM END CAP GASKET	1
5	13777	3/4" PLUG	1
6	13778	O-RING	1
7	MLS300G	3" EPDM CAP GASKET	1
8	LS304	4 SS MESH SCREEN	1
8	LS308	8 SS MESH SCREEN	1
8	LS312	12 SS MESH SCREEN	1
8	LS320	20 SS MESH SCREEN	1
8	LS350	50 SS MESH SCREEN	1
1-7	MLS300BC	STRAINER WITHOUT SCREEN	1

# MANIFOLD FLANGE CONNECTIONS

## BOTTOM DRAIN BOLTED TANK FITTINGS

### FEATURES

- Stainless steel bolts
- Bolt head plugs sealed ultrasonically
- Glass reinforced polypropylene
- EPDM gasket standard
- FKM gasket available



### BOTTOM DRAIN BOLTED TANK FITTINGS

PART NO	DESCRIPTION	MAX PSI	LOT QTY
MBF100BD	1" FLANGE X 1" FEMALE THREAD W/EPDM GASKET	150	5
MBF200BD	2" FLANGE X 2" FEMALE THREAD W/EPDM GASKET	150	5
MBF220BD	2" FP FLANGE X 2" FEMALE THREAD W/EPDM GASKET	150	5
MBF300BD	3" FLANGE X 3" FEMALE THREAD W/EPDM GASKET	150	8

## BOTTOM DRAIN BULKHEAD FITTINGS

### FEATURES

- Glass reinforced polypropylene
- EPDM standard
- Groove allows more drainage
- Gasket not included



### BOTTOM DRAIN BULKHEAD FITTINGS

PART NO	DESCRIPTION	HOLE SIZE	MAX PSI	LOT QTY
MTF100BD	1" FLANGE X 1" FEMALE THREAD W/EPDM GASKET	2 1/4"	300	10
MTF220BD	2" FP FLANGE X 2" FEMALE THREAD W/EPDM GASKET	3 1/4"	300	10
MTF300BD	3" FLANGE X 3" FEMALE THREAD W/EPDM GASKET	4 1/2"	200	1

## BOLTED TANK FITTINGS

### FEATURES

- Stainless steel bolts
- Bolt head plugs sealed ultrasonically
- Glass reinforced polypropylene
- EPDM gasket standard
- FKM gasket available



### BOLTED TANK FITTINGS

PART NO	DESCRIPTION	MAX PSI	LOT QTY
MBF100	1" FLANGE X 1" FEMALE THREAD W/EPDM GASKET	150	5
MBF200	2" FLANGE X 2" FEMALE THREAD W/EPDM GASKET	150	5
MBF220	2" FP FLANGE X 2" FEMALE THREAD W/EPDM GASKET	150	5
MBF300	3" FLANGE X 3" FEMALE THREAD W/EPDM GASKET	150	5

**MAX WALL THICKNESS  
CHART ON PAGE 160**

## NOT YOUR TYPICAL SPILLAGE

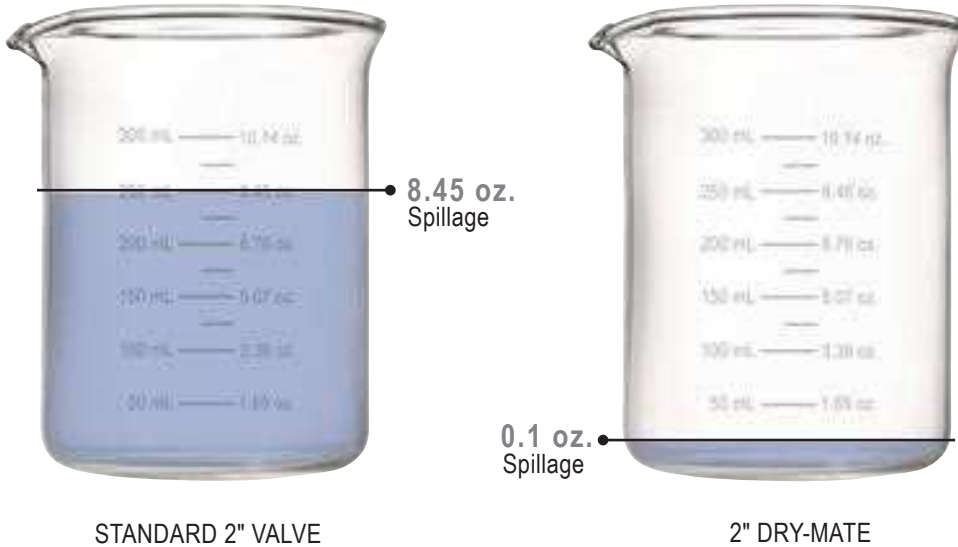

### 99% SPILLAGE REDUCTION

- Reduction of typical spillage using standard 2" valve with cam lock connection vs. Dry-Mate
- 8.45 oz. (250 mL) vs. 0.1 oz. (3 mL) spillage
- At five disconnections per day, this is **over 118 gallons (450 liters) saved per year**; enough to fill the gas tanks of eight mid-size automobiles

### FEATURES



#### SAFETY FIRST

Product is important, but the safety of your team is essential. With Dry-Mate Dry-Disconnects, leakage from disconnecting is miniscule compared to standard valves. When properly installed and operated, the danger posed by harmful chemicals contacting your team is greatly reduced.



#### EVERY DROP COUNTS

Your product is money. Why waste money in spilling your product every time you disconnect? With Dry-Mate, your spillage amount will be significantly reduced. At 3 mL product spillage for a 2" line, you can have peace of mind that your product is being placed where it should be and not on the ground.



#### PRODUCT ONLY WHERE YOU WANT IT

When a Dry-Mate is properly installed and operated, the assembly will not accidentally separate while fluid is flowing; preventing costly mishaps.



#### DITCH THE MAINTENANCE

All that spillage has to go somewhere. If you are collecting large areas of spillage run-off, you have to have it pumped out. Reduce your maintenance costs on your spillage pits by keeping fluids contained.

# DRY DISCONNECTS

## 1½" POLY DRY-MATES

### FEATURES

- Lightweight
- Easy to use
- Economical
- Reduces risk of exposure
- Wide range of chemical resistance
- Unrestricted 1½" flow
- Patented double ball design with cam lever connection
- When properly installed and operated, the assembly will not accidentally separate while fluid is flowing; preventing costly mishaps
- Spillage data: 1½" = 2ml



### REPAIR KIT INCLUDES:

- Ball
- Body gasket
- Thrust washer
- Ball seats
- Upper stem bushing
- Stem o-ring

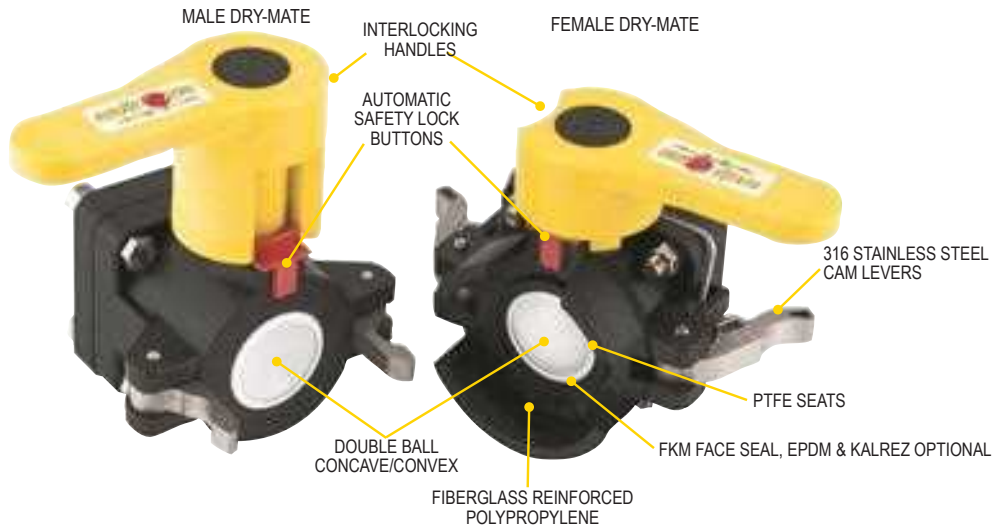

### 1½" POLY MALE DRY-MATE

PART NO	DESCRIPTION	MAX PSI	PIPE SIZE	OPENING THRU BALL	QTY
DM150A	1½" MALE X FPT NPT W/FKM SEALS	100	1½"	1½"	1
DM150AB	1½" MALE X FPT BSP W/FKM SEALS	100	1½"	1½"	1
DM150AE	1½" MALE X FPT NPT W/EPDM SEALS	100	1½"	1½"	1

### 1½" POLY FEMALE DRY-MATE

PART NO	DESCRIPTION	MAX PSI	PIPE SIZE	OPENING THRU BALL	QTY
DM150D	1½" FEMALE X FPT NPT W/FKM SEALS	100	1½"	1½"	1
DM150DB	1½" FEMALE X FPT BSP W/FKM SEALS	100	1½"	1½"	1
DM150DE	1½" FEMALE X FPT NPT W/EPDM SEALS	100	1½"	1½"	1

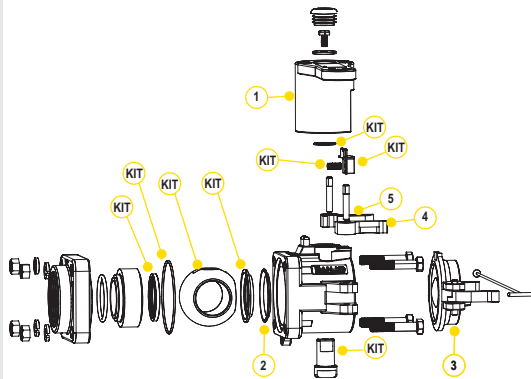

### REPLACEMENT PARTS MALE

ITEM	PART NO	DESCRIPTION	QTY
1	DM20153M	MALE HANDLE	1
1	DB20153M	LOW PROFILE HANDLE	1
2	DB20290	FKM FACE SEAL	1
2	DB20295	EPDM FACE SEAL	1
2	DM20296	KALREZ® FACE SEAL	1
3	DM200CAP	DUST CAP	1
4	DM20300	PROFILE INSERT	2
5	200P	PIN	2
KIT	DM20200A	REPAIR KIT FOR DM150A	1

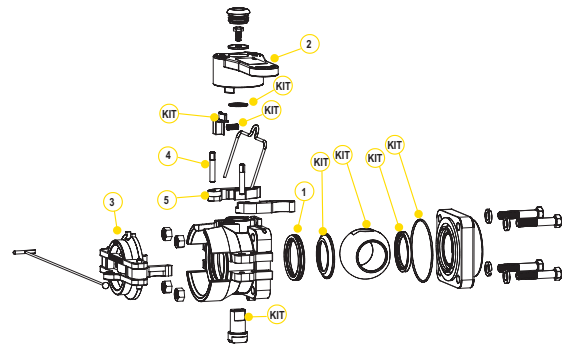

### REPLACEMENT PARTS FEMALE

ITEM	PART NO	DESCRIPTION	QTY
1	DM20294A	FKM FACE SEAL	1
1	D20295A	EPDM FACE SEAL	1
1	DM20296	KALREZ® FACE SEAL	1
2	DM20153F	FEMALE HANDLE	1
3	DM200PL	DUST PLUG	1
4	200P	PIN	2
5	DM200KX	CAM ARM	2
KIT	DM20200D	REPAIR KIT FOR DM150D	1

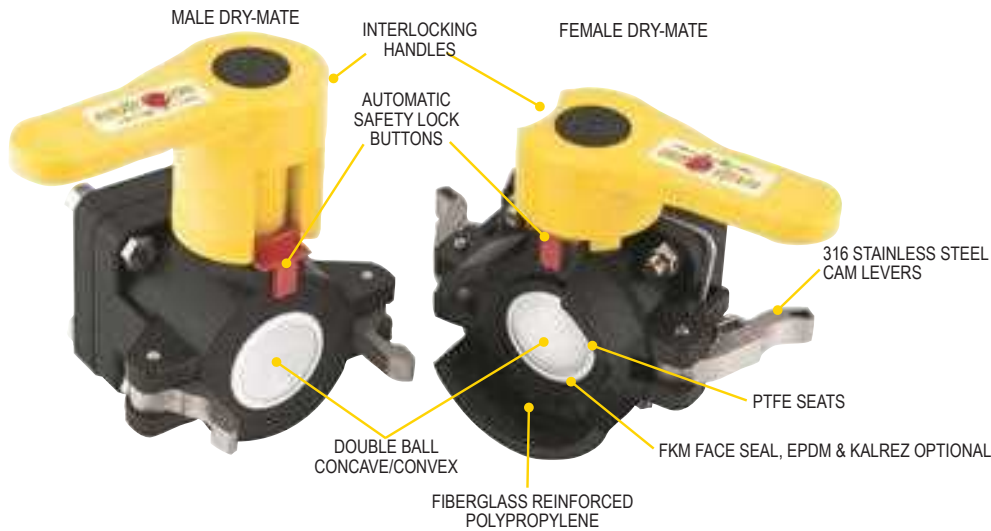

## 2" POLY DRY-MATES

### FEATURES

- Lightweight
- Easy to use
- Economical
- Reduces risk of exposure
- Wide range of chemical resistance
- Unrestricted 1½" flow
- Patented double ball design with cam lever connection
- When properly installed and operated, the assembly will not accidentally separate while fluid is flowing; preventing costly mishaps
- Spillage data: 2" = 2.6ml

### 2" POLY MALE DRY-MATE

PART NO	DESCRIPTION	MAX PSI	PIPE SIZE	OPENING THRU BALL	QTY
DM200A	2" MALE X FPT NPT W/FKM SEALS	100	2"	1½"	1
DM200AB	2" MALE X FPT BSP W/FKM SEALS	100	2"	1½"	1
DM200AE	2" MALE X FPT NPT W/EPDM SEALS	100	2"	1½"	1
DM200AT	2" MALE X FPT NPT W/KALREZ® SEALS	100	2"	1½"	1
DMMT201A	2" MALE X MALE NPT W/LOW PROFILE HANDLE	100	2"	1½"	1

### 2" POLY FEMALE DRY-MATE

PART NO	DESCRIPTION	MAX PSI	PIPE SIZE	OPENING THRU BALL	QTY
DM200D	2" FEMALE X FPT NPT W/FKM SEALS	100	2"	1½"	1
DM200DB	2" FEMALE X FPT BSP W/FKM SEALS	100	2"	1½"	1
DM200DE	2" FEMALE W/EPDM SEALS	100	2"	1½"	1
DM200DT	2" FEMALE X FPT NPT W/KALREZ® SEALS	100	2"	1½"	1



### REPAIR KIT INCLUDES:

- Ball
- Body gasket
- Thrust washer
- Ball seats
- Upper stem bushing
- Stem o-ring

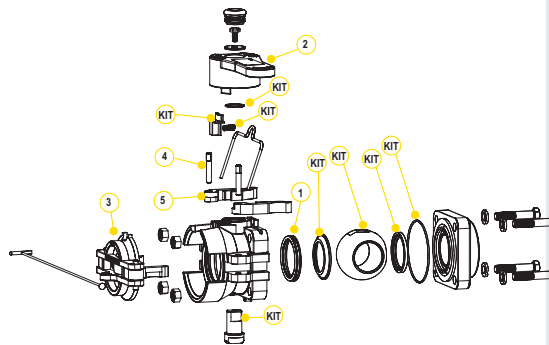
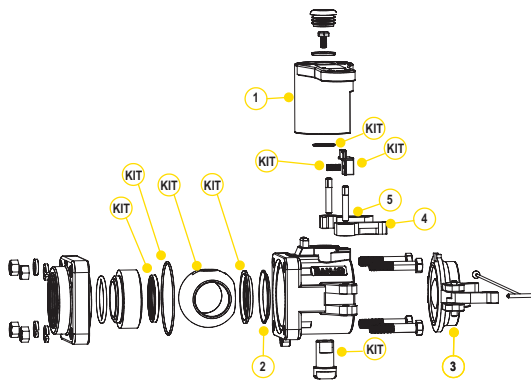

### REPLACEMENT PARTS MALE

ITEM	PART NO	DESCRIPTION	QTY
1	DM20153M	MALE HANDLE	1
1	DB20153M	LOW PROFILE HANDLE	1
2	DB20290	FKM FACE SEAL	1
2	DB20295	EPDM FACE SEAL	1
2	DM20296	KALREZ® FACE SEAL	1
3	DM200CAP	DUST CAP	1
4	DM20300	PROFILE INSERT	2
5	200P	PIN	2
KIT	DM20200A	REPAIR KIT FOR DM200A & DM200AE	1

### REPLACEMENT PARTS FEMALE

ITEM	PART NO	DESCRIPTION	QTY
1	DM20294A	FKM FACE SEAL	1
1	DM20295A	EPDM FACE SEAL	1
1	DM20296	KALREZ® FACE SEAL	1
2	DM20153F	FEMALE HANDLE	1
3	DM200PL	DUST PLUG	1
4	200P	PIN	2
5	DM200KX	CAM ARM	2
KIT	DM20200D	REPAIR KIT FOR DM200D & DM200DE	1

# DRY DISCONNECTS

## 2" FULL PORT POLY DRY-MATES

### FEATURES

- Lightweight
- Easy to use
- Economical
- Reduces risk of exposure
- Wide range of chemical resistance
- Unrestricted 2" flow
- Patented double ball design with cam lever connection
- When properly installed and operated, the assembly will not accidentally separate while fluid is flowing; preventing costly mishaps
- Spillage data: 2" FP = 3.6ml



DM220D

DM220A

2" FULL PORT POLY DRY-MATES					
PART NO	DESCRIPTION	MAX PSI	PIPE SIZE	OPENING THRU BALL	QTY
DM220D	2" FEMALE X FPT NPT W/FKM SEALS	225	2"	2"	1
DM220A	2" MALE X FPT W/FKM SEALS	225	2"	2"	1



### REPAIR KIT INCLUDES:

- Body gasket
- Thrust washer
- Ball seats
- Upper stem bushing
- Stem o-ring
- Face seal

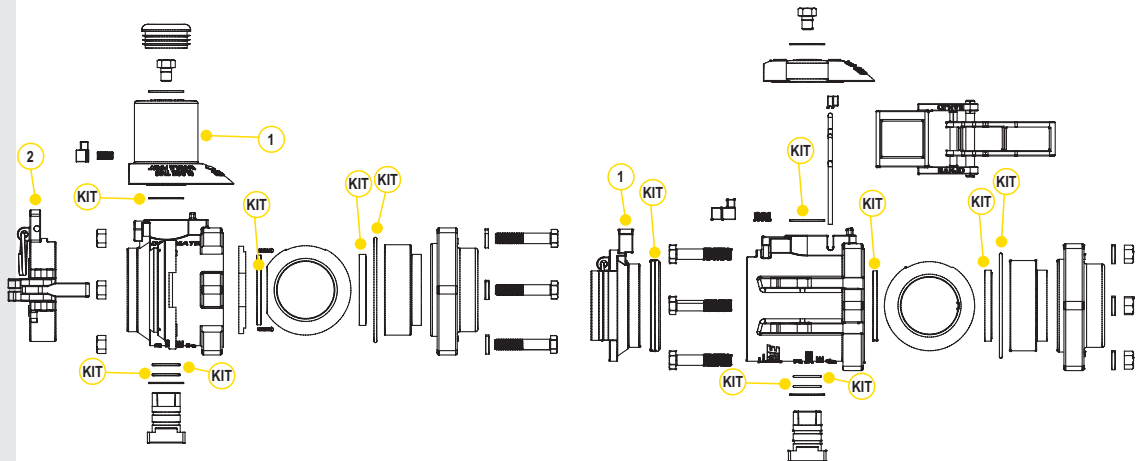

REPLACEMENT PARTS MALE			
ITEM	PART NO	DESCRIPTION	QTY
1	DM25153M	MALE HANDLE	1
2	DM220CAP	DUST CAP	1
KIT	DM25200	REPAIR KIT	1

REPLACEMENT PARTS FEMALE			
ITEM	PART NO	DESCRIPTION	QTY
1	DM25153F	FEMALE HANDLE	1
2	DM221PL	DUST PLUG	1
KIT	DM25200	REPAIR KIT	1

## 3" FULL PORT POLY DRY-MATES

### FEATURES

- Lightweight
- Easy to use
- Economical
- Reduces risk of exposure
- Wide range of chemical resistance
- Unrestricted 3" flow
- Patented double ball design with cam lever connection
- When properly installed and operated, the assembly will not accidentally separate while fluid is flowing; preventing costly mishaps
- Spillage data: 3" = 20ml



### REPAIR KIT INCLUDES:

- Ball
- Body gasket
- Thrust washer
- Ball seats
- Upper stem bushing
- Stem o-ring
- Face seal



DM300DFP



DM300AFP

### 3" FULL PORT POLY DRY-MATES

PART NO	DESCRIPTION	MAX PSI	PIPE SIZE	OPENING THRU BALL	QTY
DM300AFP	3" FP MALE X 3" FEMALE NPT THREADS W/ FKM SEALS	150	3"	3"	1
DM300DFP	3" FP FEMALE X 3" FEMALE NPT THREADS W/ FKM SEALS	150	3"	3"	1

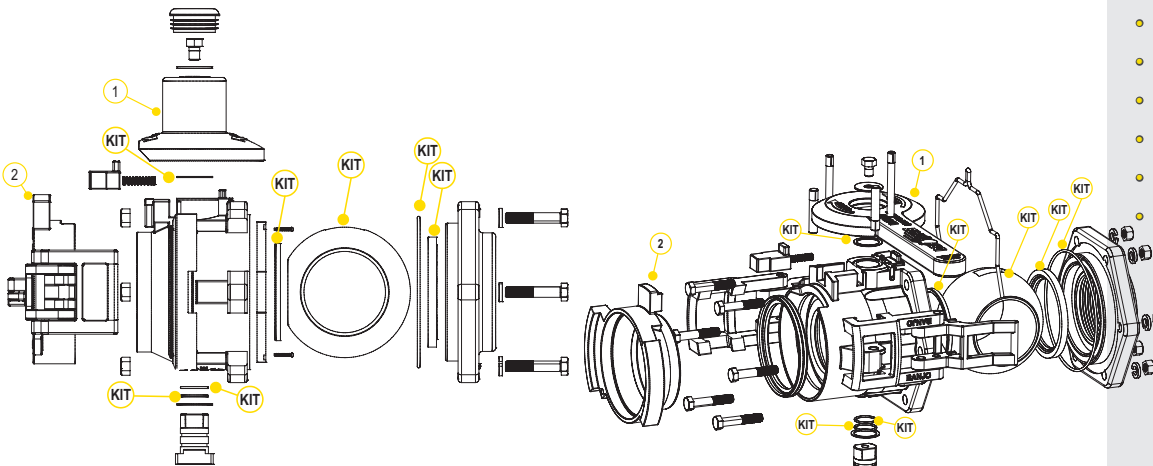

### REPLACEMENT PARTS MALE

ITEM	PART NO	DESCRIPTION	QTY
1	DM35153M	MALE HANDLE	1
2	DM300CAP	DUST CAP	1
KIT	DM35200	REPAIR KIT	1

### REPLACEMENT PARTS FEMALE

ITEM	PART NO	DESCRIPTION	QTY
1	DM35153F	FEMALE HANDLE	1
2	DM300PL	DUST PLUG	1
KIT	DM35200	REPAIR KIT	1

# DRY DISCONNECTS

## 1" FULL PORT STAINLESS STEEL DRY-MATES

### FEATURES

- 316 stainless steel construction
- Unrestricted 1" flow
- Patented double ball design with cam lever connection
- 300°F maximum operating temperature
- 100% PTFE ball seats
- When properly installed and operated, the assembly will not accidentally separate while fluid is flowing; preventing costly mishaps
- Spillage data: 1" FP = 1.7ml

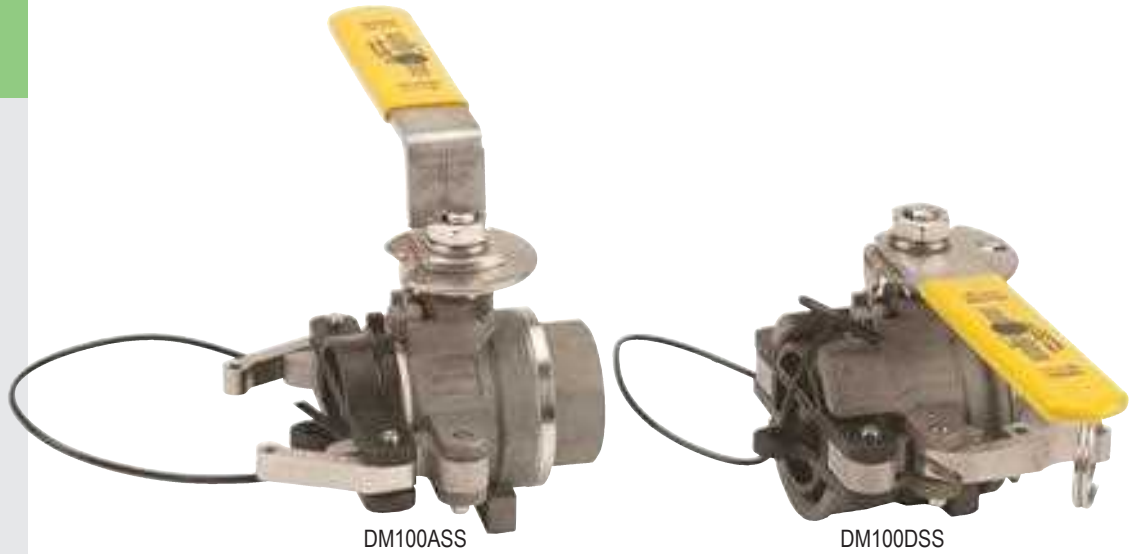

DM100ASS

DM100DSS

### 1" FULL PORT STAINLESS STEEL DRY-MATE

PART NO	DESCRIPTION	MAX PSI	PIPE SIZE	OPENING THRU BALL	QTY
DM100ASS	1" MALE X FPT NPT W/ PTFE SEALS	150	1"	1"	1
DM100ABSS	1" MALE X BSPP W/ PTFE SEALS	150	1"	1"	1
DM100DSS	1" FEMALE X FPT NPT W/ FKM SEALS	150	1"	1"	1
DM100DSSE	1" FEMALE X FPT NPT W/ EPDM SEALS	150	1"	1"	1
DM100DBSS	1" FEMALE X BSPP W/ FKM SEALS	150	1"	1"	1



### REPAIR KIT INCLUDES:

- Ball
- Body gasket
- Thrust washer
- Ball seats
- Upper stem bushing
- Stem o-ring
- Face seal

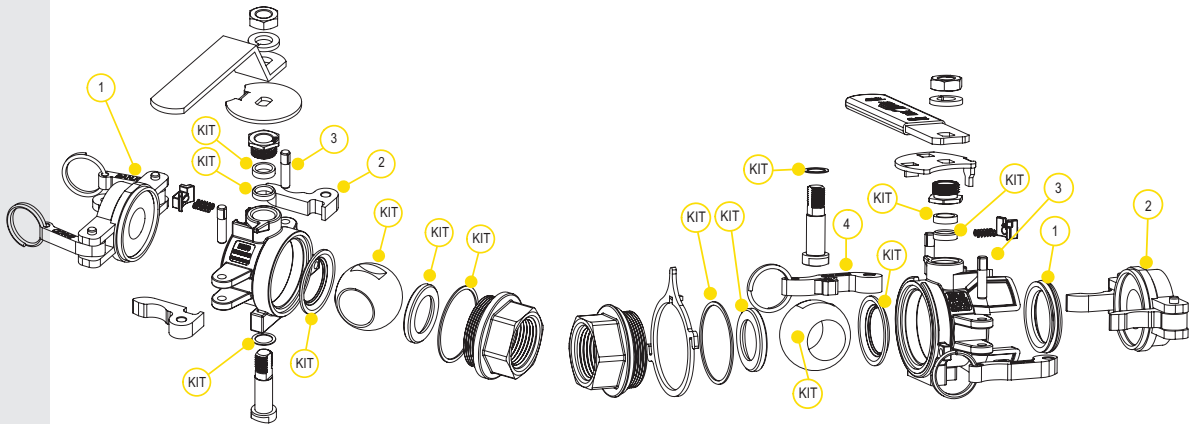

### REPLACEMENT PARTS MALE

ITEM	PART NO	DESCRIPTION	QTY
1	DM100CAP	DUST CAP	1
2	DM10300	PROFILE INSERT	2
3	100P	PIN	2
KIT	DM101SS	REPAIR KIT	1

### REPLACEMENT PARTS FEMALE

ITEM	PART NO	DESCRIPTION	QTY
1	DM10294A	FKM FACE SEAL	1
1	DM10295A	EPDM FACE SEAL	1
1	DM10296	KALREZ® FACE SEAL	1
2	DM100PL	POLY PLUG	1
3	100P	PIN	2
4	DM100K	CAM ARM	2
KIT	DM102SSV	FKM REPAIR KIT	1

# DRY DISCONNECTS

## 1½" FULL PORT STAINLESS STEEL DRY-MATES



DM150ASS



DM150DSS

### 1½" FULL PORT STAINLESS STEEL DRY-MATE

PART NO	DESCRIPTION	MAX PSI	PIPE SIZE	OPENING THRU BALL	QTY
DM150ASS	1½" MALE X FPT NPT W/ PTFE SEALS	150	1½"	1½"	1
DM150ABSS	1½" MALE X BSPP W/ PTFE SEALS	150	1½"	1½"	1
DM150DSS	1½" FEMALE X FPT NPT W/ FKM SEALS	150	1½"	1½"	1
DM150DSSE	1½" FEMALE X FPT NPT W/ EPDM SEALS	150	1½"	1½"	1
DM150DBSS	1½" FEMALE X BSPP W/ FKM SEALS	150	1½"	1½"	1



### REPAIR KIT INCLUDES:

- Ball
- Body gasket
- Thrust washer
- Ball seats
- Upper stem bushing
- Stem o-ring
- Face seal

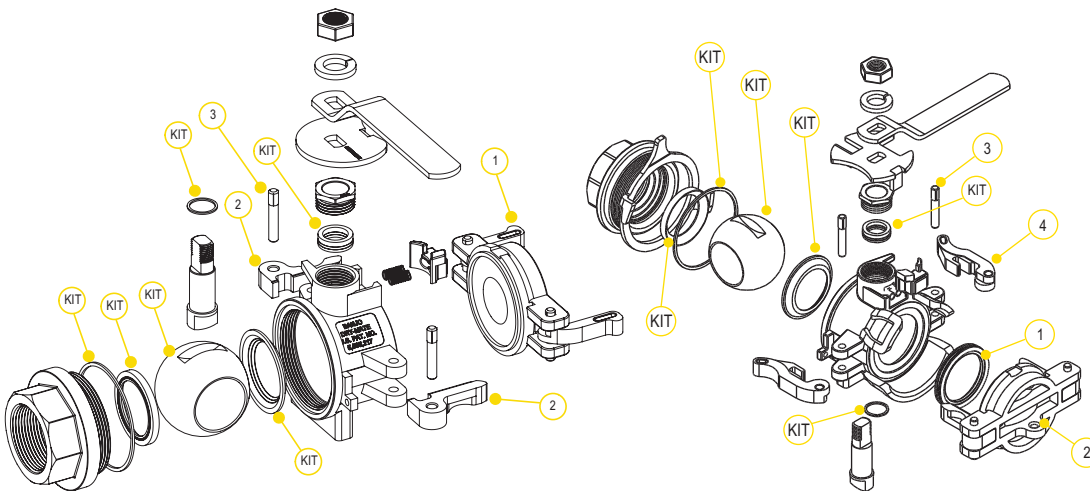

### REPLACEMENT PARTS MALE

ITEM	PART NO	DESCRIPTION	QTY
1	DM200ACAP	DUST CAP	1
2	DM20300	PROFILE INSERT	2
3	200P	PIN	2
KIT	DM201SS	REPAIR KIT	1

### REPLACEMENT PARTS FEMALE

ITEM	PART NO	DESCRIPTION	QTY
1	DM20294A	FKM FACE SEAL	1
1	DM20295A	EPDM FACE SEAL	1
1	DM20296	KALREZ® FACE SEAL	1
2	DM200APL	DUST PLUG	1
3	200P	PIN	2
4	DM200KX	CAM ARM	2
KIT	DM202SSV	FKM REPAIR KIT	1

# DRY DISCONNECTS

## 2" STAINLESS STEEL DRY-MATES

### FEATURES

- 316 stainless steel construction
- Patented double ball design with cam lever connection
- 300°F maximum operating temperature
- 100% PTFE ball seats
- When properly installed and operated, the assembly will not accidentally separate while fluid is flowing; preventing costly mishaps
- Spillage data: 2" = 3.6ml



DM200ASS



DM200DSS

### 2" STANDARD PORT STAINLESS STEEL DRY-MATE

PART NO	DESCRIPTION	MAX PSI	PIPE SIZE	OPENING THRU BALL	QTY
DM200ASS	2" MALE X FPT NPT W/ PTFE SEALS	150	2"	1½"	1
DM200ABSS	2" MALE X BSPP W/ PTFE SEALS	150	2"	1½"	1
DM200DSS	2" FEMALE X FPT NPT W/ FKM SEALS	150	2"	1½"	1
DM200DSSST	2" FEMALE X FPT NPT W/ KALREZ® SEALS	150	2"	1½"	1
DM200DBSS	2" FEMALE X BSPP W/ FKM SEALS	150	2"	1½"	1



### REPAIR KIT INCLUDES:

- Ball
- Body gasket
- Thrust washer
- Ball seats
- Upper stem bushing
- Stem o-ring
- Face seal

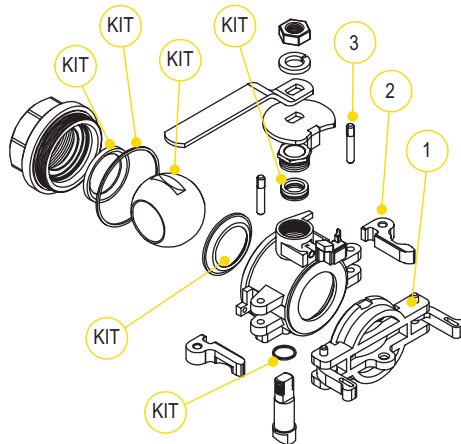

### REPLACEMENT PARTS MALE

ITEM	PART NO	DESCRIPTION	QTY
1	DM200ACAP	DUST CAP	1
2	DM20300	PROFILE INSERT	2
3	200P	PIN	2
KIT	DM201SS	REPAIR KIT	1

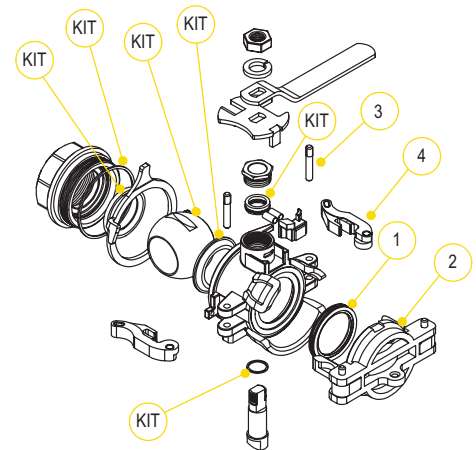

### REPLACEMENT PARTS FEMALE

ITEM	PART NO	DESCRIPTION	QTY
1	DM20294A	FKM FACE SEAL	1
1	DM20295A	EPDM FACE SEAL	1
1	DM20296	KALREZ® FACE SEAL	1
2	DM200APL	POLY PLUG	1
3	200P	PIN	2
4	DM200KX	CAM ARM	2
KIT	DM202SSV	FKM REPAIR KIT	1

# DRY DISCONNECTS

## 2" FULL PORT STAINLESS STEEL DRY-MATES



DM220ABSS



DM220DBSS

### FEATURES

- 316 stainless steel construction
- Unrestricted 2" flow
- Patented double ball design with cam lever connection
- 300°F maximum operating temperature
- 100% PTFE ball seats
- When properly installed and operated, the assembly will not accidentally separate while fluid is flowing; preventing costly mishaps
- Spillage data: 2" FP = 3.8ml

### 2" FULL PORT STAINLESS STEEL DRY-MATE

PART NO	DESCRIPTION	MAX PSI	PIPE SIZE	OPENING THRU BALL	QTY
DM220ASS	2" FULL PORT MALE X FPT NPT W/ PTFE SEALS	300	2"	2"	1
DM220ABSS	2" FULL PORT MALE X BSPP W/ PTFE SEALS	300	2"	2"	1
DM220DSS	2" FULL PORT FEMALE X FPT NPT W/ FKM SEALS	300	2"	2"	1
DM220DBSS	2" FULL PORT FEMALE X BSPP W/ FKM SEALS	300	2"	2"	1



### REPAIR KIT INCLUDES:

- Body gasket
- Thrust washer
- Ball seats
- Upper stem bushing
- Stem o-ring

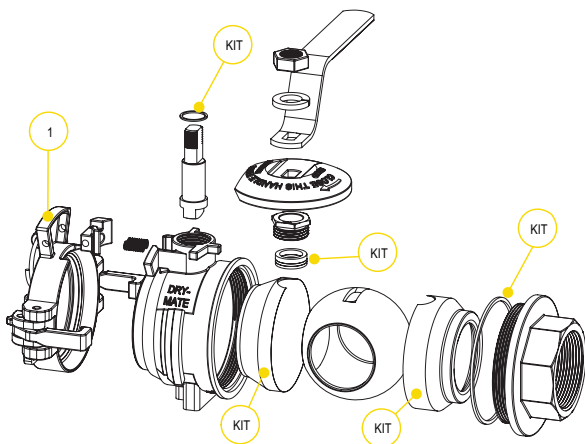

### REPLACEMENT PARTS MALE

ITEM	PART NO	DESCRIPTION	QTY
1	DM220CAP	DUST CAP	1
KIT	DM221SS	REPAIR KIT	1

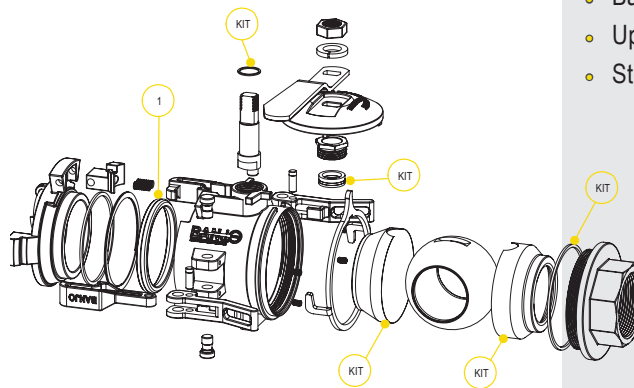

### REPLACEMENT PARTS FEMALE

ITEM	PART NO	DESCRIPTION	QTY
1	DM25294	FKM FACE SEAL	1
1	DM25294T	KALREZ® FACE SEAL	1
KIT	DM222SS	REPAIR KIT	1

# DRY DISCONNECTS

## 1" POLY DRY FITS

### FEATURES

- Double poly-ball valves with integrated quick disconnect
- 1" full-port (unrestricted flow)
- Allows higher pressures & flow
- Economical and simpler design without handle locking feature
- **90+ less spillage** vs. 2 standard valves connected via a coupling



### 1 1/2" POLY MALE DRY FIT™

PART NO	DESCRIPTION	MAX PSI	PIPE SIZE	OPENING THRU BALL	QTY
DF100A	1" MALE X FPT NPT W/FKM SEALS	100	1"	1"	1

### 1 1/2" POLY FEMALE DRY FIT™

PART NO	DESCRIPTION	MAX PSI	PIPE SIZE	OPENING THRU BALL	QTY
DF100D	1" FEMALE X FPT NPT W/FKM SEALS	100	1"	1"	1



### UNIVERSAL DRY FIT™ KIT

PART NO	DESCRIPTION	QTY
DF10200	REPAIR KIT FOR DF100A OR DF100D	1

**\*Note:** Kit includes female camlock gasket not shown in breakdowns.

Repair kit includes

- Ball
- Ball seats (x2)
- Endplate o-ring
- Stem
- Stem o-rings (x2)
- Female camlock gasket

## DRY POPPET COUPLINGS

### FEATURES

- Lightweight
- Minimal fluid spillage
- Easy to use
- Economical
- Reduces risk of exposure
- Wide range of chemical resistance
- Maximum operating temperature 150° F
- 30 GPM maximum flow
- Precision molded in polypropylene
- 1" female NPT threads

### APPLICATIONS

- Agriculture
- Industrial
- Pharmaceutical
- Chemical processing

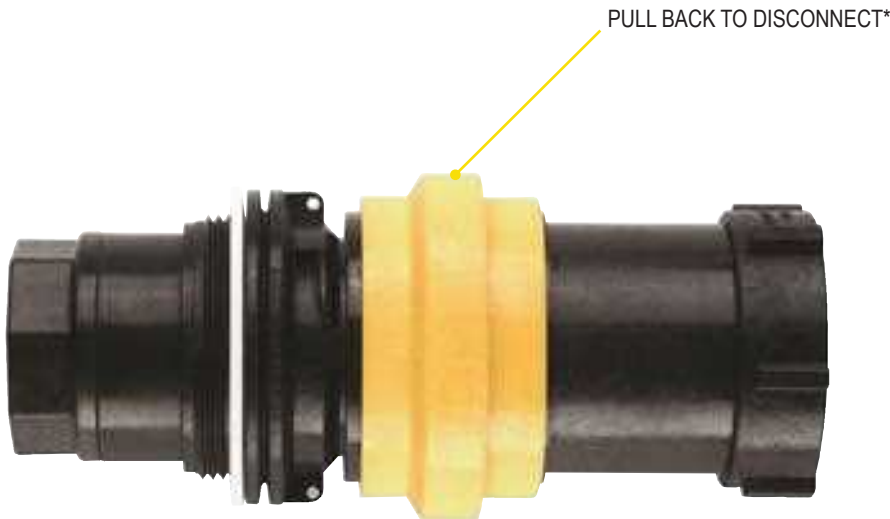

### DRY POPPET COUPLINGS

PART NO	DESCRIPTION	MAX PSI	QTY
DPCF100	FEMALE DRY POPPET COUPLER, 1" FEMALE NPT THREADS W/ FKM SEALS	100	1
DPCM100	MALE DRY POPPET ADAPTER, 1" FEMALE NPT THREADS W/ FKM SEALS	150	1
DPCMT100	MALE DRY POPPET ADAPTER, W/2" MALE THREADED BODY 1" FEMALE NPT THREADS W/ FKM SEALS	150	1

**\*Note:** Male adapter and female coupler shown coupled together but sold separately.

# IBC/TANK ACCESSORIES

## SPIN WELD BALL VALVES

### FEATURES

- PTFE seats
- FKM stem o-rings
- Precision molded polypropylene is reinforced with fiberglass for additional strength
- Zinc alloy collar
- FKM, EPDM and TPV collar gaskets available
- Handles close in either direction
- For faster shipping, order in box quantities



W230237



W230238



W230239



W230240



WSF210FSA



WSF210FSAV



WSMT210FSA



WSMT210FSAV

IDENTIFYING COLLAR NUMBER FOUND HERE

### SPINWELD BALL VALVE

PART NO	DESCRIPTION	GASKET MATERIAL	COLLAR FITS	COLLAR NUMBER	COLLAR ID	MAX PSI	QTY
W230237	2" POLY SPINWELD VALVE W/NPT OUTLET & CAP & FOIL SEAL	FKM	MAUSER®	V22283 C & D	2 1/4"	20	1
W230238	2" POLY SPINWELD VALVE W/QDC OUTLET & CAP & FOIL SEAL	FKM	MAUSER®	V22283 C & D	2 1/4"	20	1
W230239	2" POLY SPINWELD VALVE W/NPT OUTLET & CAP & FOIL SEAL	EPDM	MAUSER®	V22283 C & D	2 1/4"	20	1
W230240	2" POLY SPINWELD VALVE W/QDC OUTLET & CAP & FOIL SEAL	EPDM	MAUSER®	V22283 C & D	2 1/4"	20	1
WSF210FSA	2" POLY SPINWELD VALVE W/QDC OUTLET, FOIL SEAL & CAP	TPV	SCHUTZ®	V20280 A & B	2 3/4"	50	1
WSF210FSAV	2" POLY SPINWELD VALVE W/QDC OUTLET, FOIL SEAL & CAP	FKM	SCHUTZ®	V20280 A & B	2 3/4"	50	1
WSMT210FSA	2" POLY SPINWELD VALVE W/NPT OUTLET, FOIL SEAL & CAP	TPV	SCHUTZ®	V20280 A & B	2 3/4"	225	1
WSMT210FSAV	2" POLY SPINWELD VALVE W/NPT OUTLET, FOIL SEAL & CAP	FKM	SCHUTZ®	V20280 A & B	2 3/4"	225	1

## FDA UNION VALVE AND ADAPTERS



MBP200



NIP2101



UV204FPFD

### FEATURES

- Precision molded in glass reinforced polypropylene for strength and chemical resistance
- PTFE seats or smooth operation and proper sealing characteristics
- Double EPDM o-rings in stem area for extra sealing protection
- Interlocking body and end plate to allow easy thread connection when installing valves

### UNION VALVE AND ADAPTERS

PART NO	DESCRIPTION	MAX PSI	QTY
MBP200	2" BUTTRESS X 2" NPT ASSEMBLY	200	1
NIP2101	2" NPT X BSP NIPPLE	300	1
UV204FPFD	2" FDA UNION VALVE WITH EPDM	225	1

# IBC/TANK ACCESSORIES

## TANK LIDS

### FEATURES

- Maximum air flow through vent channels
- Airflow equivalent to a 3" hole
- No secondary venting needed
- Baffled vents
- Center vent goes in underside of lid
- NPT Threads



### IBC SOLID TANK LIDS

PART NO	DESCRIPTION	GASKET	LOT QTY
TL650S	6" SOLID TANK LID W/GASKET	TPV	10

### IBC TANK LID WITH UNVENTED PLUG

PART NO	DESCRIPTION	GASKET	LOT QTY
TL651S	6" TANK LID W/ UNVENTED 2" PLUG W/GASKET	TPV	10

### IBC TANK LIDS WITH VENTED PLUG

PART NO	DESCRIPTION	GASKET	QTY
TL652S	6" TANK LID W/ VENTED 2" PLUG W/GASKET	TPV	1
TL652E	6" TANK LID VENTED 2" PLUG W/GASKET	EPDM	1

### TANK LID FOR SPRAY TANKS

PART NO	DESCRIPTION	GASKET	QTY
TL600C	6" VENTED TANK LID	N/A	1

### VENTED TANK LIDS

PART NO	DESCRIPTION	GASKET	QTY
TLVA10	10" VENTED TANK LID & RING ASSEMBLY (NEW STYLE)	N/A	1

## SIPHON TUBES

### FEATURES

- Full flow size
- Long length
- Male NPT threads
- Made of polypropylene



### SIPHON TUBES

PART NO	DESCRIPTION	LOT QTY
ST200	2" POLY SIPHON TUBE	5
ST300	3" POLY SIPHON TUBE	5



## POLYPROPYLENE ACCESSORIES

### FEATURES

- Glass reinforced polypropylene

### BUTTRESS BY MALE ADAPTER

PART NO	DESCRIPTION	GASKET	PSI	LOT QTY
TA283	2" BUTTRESS X 2" MALE NPT THREADS W/GASKET	TPV	300	10
TA283QD	2" BUTTRESS X 2" MALE ADAPTER QDC W GASKET	TPV	150	10



### CAPS

PART NO	DESCRIPTION	PSI	QTY
201FPT	2" FEMALE NPT CAP - BLACK	20	1
211FPT	2" FEMALE NPT CAP - YELLOW	N/A	1



### BUNG PLUGS

PART NO	DESCRIPTION	QTY
231MPT	2" MPT SOLID BUNG W/ EPDM GASKET	1
TL6531	2" VENTED PLUG W/ EPDM GASKET	1



### DUST CAPS & LANYARD

PART NO	DESCRIPTION	PSI	LOT QTY
200CAP	2" CAM LEVER DUST CAP	200	20
200CAPSH	2" CAM LEVER DUST CAP WITH SHORT ARMS	200	10
201CAPSH	2" CAM LEVER DUST CAP W/SHORT ARMS & RINGS	200	10
202CAP	2" CAM LEVER DUST CAP	20	10
V20207	11" POLYURETHANE LANYARD	N/A	1

# IBC/TANK ACCESSORIES

## BOLTED TANK FLANGES

### FEATURES

- Stainless steel bolts
- Bolt head plugs ultrasonically sealed
- Glass reinforced polypropylene
- EPDM gaskets standard and FKM available
- **WARNING:** Do not tighten tank flange bolts more than 12 ft pounds



BF150



BF300



### BOLTED TANK FLANGES

PART NO	DESCRIPTION	LOT QTY
BF075	3/4" X 1" THREADED FLANGE W/EPDM GASKET	10
BF100	1" X 1" THREADED FLANGE W/EPDM GASKET	10
BF150	1 1/2" X 2" THREADED FLANGE W/EPDM GASKET	5
BF150V	1 1/2" X 2" THREADED FLANGE W/FKM GASKET	1
BF200	2" X 2" THREADED FLANGE W/EPDM GASKET	10
BF200V	2" X 2" THREADED FLANGE W/FKM GASKET	10
BF220	2" X 2" FP THREADED FLANGE W/EPDM GASKET	5
BF300	3" X 3" THREADED FLANGE W/EPDM GASKET	4

### BOLTED TANK FLANGE GASKETS

PART NO	DESCRIPTION	QTY
BF100GE	1" EPDM GASKET	1
BF200GE	1 1/2" & 2" EPDM GASKET	1
BF200GV	1 1/2" & 2" FKM GASKET	1
BF220GE	2" FULL PORT EPDM GASKET	1
BF220GV	2" FULL PORT FKM GASKET	1
BF300GE	3" EPDM GASKET	1
BF300GV	3" FKM GASKET	1

3/4" — 2"

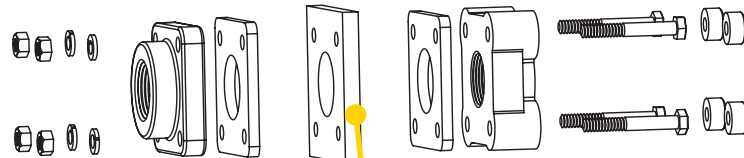

Tank Wall

3"

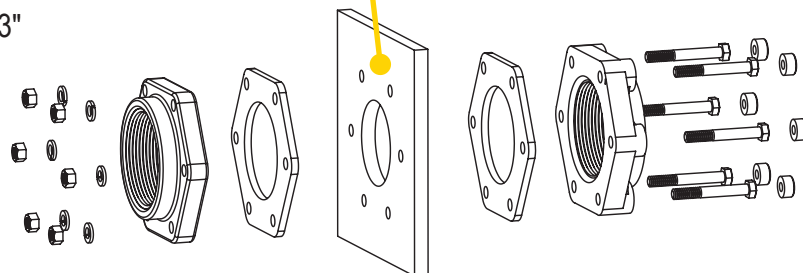

## BOLTED BOTTOM DRAIN TANK FLANGES



### FEATURES

- Stainless steel bolts
- Bolt head plugs ultrasonically sealed
- Glass reinforced polypropylene
- EPDM gaskets standard and FKM available
- Allows 100% rinse free
- No sediment build up
- Excellent for avoiding herbicide cross contamination
- Fits most cone bottom and chemical inductor tanks, 30 gallons and larger.
- For faster shipping, order in box quantities



### BOLTED TANK FLANGES

PART NO	DESCRIPTION	LOT QTY
BF075BD	3/4" X 1" THREADED POLY FLANGE W/ EPDM GASKET	5
BF100BD	1" X 1" THREADED POLY FLANGE W/EPDM GASKET	5
BF150BD	1 1/2" X 2" THREADED POLY FLANGE W/EPDM GASKET	5
BF200BD	2" X 2" THREADED POLY FLANGE W/EPDM GASKET	5
BF220BD	2" X 2" FULL PORT THREADED POLY FLANGE W/EPDM GASKET	5
BF300BD	3" X 3" THREADED POLY FLANGE W/EPDM GASKET	4

### BOLTED TANK FLANGE GASKETS

PART NO	DESCRIPTION	QTY
BF100GE	3/4", 1" & 1 1/4" EPDM GASKET	1
BF100GRE	3/4", 1" & 1 1/4" FOOT EPDM GASKET	1
BF100GRV	3/4", 1" & 1 1/4" FOOT FKM GASKET	1
BF200GE	1 1/2" & 2" EPDM GASKET	1
BF200GV	1 1/2" & 2" FKM GASKET	1
BF200GFV	1 1/2" & 2" STD. PORT. 2" FULL PORT FOOT FKM GASKET	1
BF220GE	2" FULL PORT EPDM GASKET	1
BF220GV	2" FULL PORT FKM GASKET	1
BF300GE	3" EPDM GASKET	1
BF300GV	3" FKM GASKET	1
BF300GFE	3" FOOT EPDM GASKET	1
BF300GFV	3" FOOT FKM GASKET	1



# IBC/TANK ACCESSORIES

## BULKHEAD TANK FITTINGS

### FEATURES

- Double sided female NPT threads
- Available with EPDM or FKM gasket
- Parts must be ordered in lot quantities.



### POLY BULKHEAD FITTINGS

PART NO	DESCRIPTION	HOLE SIZE	MAX PSI	LOT QTY
TF050	1/2" POLY BULKHEAD TANK FITTING W/EPDM GASKET	1 5/8"	300	10/BAG
TF050V	1/2" POLY BULKHEAD TANK FITTING W/FKM GASKET	1 5/8"	300	10/BAG
TF075	3/4" POLY BULKHEAD TANK FITTING W/EPDM GASKET	1 5/8"	300	10/BAG
TF075V	3/4" POLY BULKHEAD TANK FITTING W/FKM GASKET	1 5/8"	300	10
TF100	1" POLY BULKHEAD TANK FITTING W/EPDM GASKET	2 1/4"	300	10/BAG
TF100V	1" POLY BULKHEAD TANK FITTING W/FKM GASKET	2 1/4"	300	1
TF125	1 1/4" POLY BULKHEAD TANK FITTING W/EPDM GASKET	2 1/4"	300	10
TF125V	1 1/4" POLY BULKHEAD TANK FITTING W/FKM GASKET	2 1/4"	300	1
TF150	1 1/2" POLY BULKHEAD TANK FITTING W/EPDM GASKET	3"	300	10
TF150V	1 1/2" POLY BULKHEAD TANK FITTING W/FKM GASKET	3"	300	10
TF200	2" POLY BULKHEAD TANK FITTING W/EPDM GASKET	3"	300	10
TF200V	2" POLY BULKHEAD TANK FITTING W/FKM GASKET	3"	300	10
TF220	2" POLY BULKHEAD TANK FITTING W/EPDM GASKET	3 1/4"	300	10
TF220V	2" POLY BULKHEAD TANK FITTING W/FKM GASKET	3 1/4"	300	1
TF300	3" POLY BULKHEAD TANK FITTING W/EPDM GASKET	4 1/2"	300	5
TF300V	3" POLY BULKHEAD TANK FITTING W/FKM GASKET	4 1/2"	300	1
TF400	4" POLY BULKHEAD TANK FITTING W/EPDM GASKET	5 3/4"	225	1
TF400V	4" POLY BULKHEAD TANK FITTING W/FKM GASKET	5 3/4"	225	1

### 316 STAINLESS STEEL BULKHEAD FITTINGS

PART NO	DESCRIPTION	HOLE SIZE	MAX PSI	QTY
TF038SS	3/8" SS BULKHEAD TANK FITTING W/EPDM GASKET	1"	300	1
TF050SS	1/2" SS BULKHEAD TANK FITTING W/EPDM GASKET	1 3/8"	300	1
TF075SS	3/4" SS BULKHEAD TANK FITTING W/EPDM GASKET	1 5/8"	300	1
TF100SS	1" SS BULKHEAD TANK FITTING W/EPDM GASKET	2 1/4"	300	1
TF125SS	1 1/4" SS BULKHEAD TANK FITTING W/EPDM GASKET	2 1/4"	300	1
TF150SS	1 1/2" SS BULKHEAD TANK FITTING W/EPDM GASKET	3"	300	1
TF200SS	2" SS BULKHEAD TANK FITTING W/EPDM GASKET	3"	300	1
TF220SS	2" SS BULKHEAD TANK FITTING W/EPDM GASKET	3 1/4"	300	1
TF300SS	3" SS BULKHEAD TANK FITTING W/EPDM GASKET	4 3/8"	300	1

### BULKHEAD GASKETS

PART NO	DESCRIPTION	HOLE SIZE	FITS POLY	FITS SS	LOT QTY
100G	3/8" BULKHEAD EPDM GASKET	1"		TF038SS	25
100GV	3/8" BULKHEAD FKM GASKET	1"		TF038SS	10
TF100G	1" TANK FLANGE EPDM GASKET	2 7/32"	TF100 & TF125	TF100SS & TF125SS	25
TF100GV	1" TANK FLANGE FKM GASKET	2 7/32"	TF100 & TF125	TF100SS & TF125SS	10
TF138GV	1/2" BULKHEAD FKM GASKET	1 3/8"		TF050SS	10
150G	1/2" & 3/4" BULKHEAD EPDM GASKET	1 5/8"	TF050 & TF075	TF075SS	25
150GV	1/2" & 3/4" BULKHEAD FKM GASKET	1 5/8"	TF050 & TF075	TF075SS	10
200G	2" BULKHEAD EPDM GASKET	2 1/4"	TF100 & TF125	TF100SS & TF125SS	25
200GV	2" BULKHEAD FKM GASKET	2 1/4"	TF100 & TF125	TF100SS & TF125SS	10
300G	1 1/2" & 2" BULKHEAD EPDM GASKET	3"	TF200 & TF150	TF200SS & TF150SS	25
300GV	1 1/2" & 2" BULKHEAD FKM GASKET	3"	TF200 & TF150	TF200SS & TF150SS	10
TF220G	2" BULKHEAD EPDM GASKET	3 1/4"	TF220	TF220SS	1
TF220GV	2" BULKHEAD FKM GASKET	3 1/4"	TF220	TF220SS	1
TF300G	3" BULKHEAD EPDM GASKET	4 1/2"	TF300	TF300SS	1
TF300GV	3" BULKHEAD FKM GASKET	4 1/2"	TF300	TF300SS	1
TF400G	4" POLY BULKHEAD EPDM GASKET	5 3/4"	TF400		1
TF400GV	4" POLY BULKHEAD FKM GASKET	5 3/4"	TF400		1



## ANTI VORTEX VENT CAPS

### FEATURES

- Male NPT
- Glass reinforced polypropylene
- 304 stainless steel screen

### ANTI VORTEX VENT CAPS

PART NO	DESCRIPTION	BORE SIZE	BORE AREA	VENT AREA	LOT QTY
VC200	2" ANTI VORTEX VENT CAP WITHOUT SCREEN	2"	3.1 SQ IN	3.9 SQ IN	10
VC230	2" ANTI VORTEX VENT CAP W/12 MESH SS SCREEN	2"	3.1 SQ IN	3.9 SQ IN	10
VC300	3" ANTI VORTEX VENT CAP WITHOUT SCREEN	3"	7 SQ IN	9 SQ IN	1
VC330	3" ANTI VORTEX VENT CAP W/10 MESH SS SCREEN	3"	7 SQ IN	9 SQ IN	1



## ANTI VORTEX TANK FLANGES

### FEATURES

- Standard with FKM
- Prevents swirl in bottom of tank

### ANTI VORTEX TANK FLANGES

PART NO	DESCRIPTION	HOLE SIZE	QTY
TF100AV	1" ANTI VORTEX TANK FLANGES	2¼"	1
TF125AV	1¼" ANTI VORTEX TANK FLANGES	2¼"	1
TF150AV	1½" ANTI VORTEX TANK FLANGES	3"	1
TF200AV	2" ANTI VORTEX TANK FLANGES	3"	1

# IBC/TANK ACCESSORIES

## ANSI FLANGES

### FEATURES

- Glass reinforced polypropylene
- Heavy duty



### THREADED ANSI FLANGES

PART NO	DESCRIPTION	LOT QTY
AF100	1" FEMALE THREADED ANSI FLANGE	10/BAG
AF150	1½" FEMALE THREADED ANSI FLANGE	10/BAG
AF200	2" FEMALE THREADED ANSI FLANGE	10
AF300	3" FEMALE THREADED ANSI FLANGE	5
AF400	4" FEMALE THREADED ANSI FLANGE	1

### BLIND ANSI FLANGES

PART NO	DESCRIPTION	LOT QTY
AFB200	2" BLIND ANSI FLANGE	10/BAG
AFB300	3" BLIND ANSI FLANGE	5

### ANSI FLANGE GASKETS

PART NO	DESCRIPTION	QTY
AF100G	1" ANSI FLANGE EPDM GASKET	1
AF100GV	1" ANSI FLANGE FKM GASKET	1
AF150G	1½" ANSI FLANGE EPDM GASKET	1
AF200G	2" ANSI FLANGE EPDM GASKET	1
AF200GV	2" ANSI FLANGE FKM GASKET	1
AF300G	3" ANSI FLANGE EPDM GASKET	1
AF300GV	3" ANSI FLANGE FKM GASKET	1
AF400G	4" ANSI FLANGE EPDM GASKET	1
AF400GV	4" ANSI FLANGE FKM GASKET	1

# CAM LEVER COUPLINGS

## 1/4"-4" POLYPROPYLENE

### FEATURES

- Stainless steel rings, arms and pins
- Versatile — interchangeable with all types of cam lever couplings
- Precision molded — ensures a uniform and accurate fit
- Durable — polypropylene is glass reinforced for rugged strength
- Smooth operating — finger rings are designed for easy opening of cam levers
- Economical and superior in performance
- Parts must be ordered in lot quantities.
- 1/4" and 1/2" series couplings interchange with 3/4" size couplings. Coupling ends are 3/4" size.
- 1 1/4" series couplings interchange with 1" size couplings. Coupling ends are 1" size.
- 1 1/2" x 1 1/4" couplings interchange with 1 1/2" size couplings. Coupling ends are 1 1/2" size.



### POLYPROPYLENE CAM LEVER COUPLINGS

ITEM	DESCRIPTION	1/4"	1/2"	3/4"	1"	1 1/4"	1 1/2" x 1 1/4"	1 1/2"	2"	2 1/2"	3"	3" 3 ARMS	4" 3 ARMS
A	MALE ADAPTER X FEMALE THREAD	75A1/4	75A1/2	75A3/4	100A	125A	150125A	150A	200A		300A		400A
B	FEMALE COUPLER X MALE THREAD		75B1/2	75B3/4	100B	125B	150125B	150B	200B		300B	303B	400B
C	FEMALE COUPLER X HOSE BARB		050C	075C	100C	125C	150125C	150C	200C		300C	303C	400C
D	FEMALE COUPLER X FEMALE THREAD		050D	075D	100D	125D	150125D	150D	200D		300D		400D
E	MALE ADAPTER X HOSE BARB		050E	075E	100E	125E	150125E	150E	200E		300E		400E
F	MALE ADAPTER X MALE THREAD		050F	075F	100F	125F	150125F	150F	200F		300F		400F
PL	PLUG FOR FEMALE COUPLER		75PL	75PL	100125PL	100125PL	150PL	150PL	200PL	250PL	300PL		400PL
CAP	CAP FOR MALE ADAPTER		075CAP	075CAP	100125CAP	100125CAP	150CAP	150CAP	200CAP	250CAP	300CAP		400CAP (2 arms)
CAPSH	CAP WITH SHORT ARMS						200CAPSH						

### 1/4" SERIES POLY CAM LEVER COUPLINGS

PART NO	DESCRIPTION	MAX PSI	GASKET	LOT QTY
75A1/4	3/4" MALE ADAPTER X 1/4" FEMALE THREAD	300	N/A	10/BAG

### 1/2" SERIES POLY CAM LEVER COUPLINGS

PART NO	DESCRIPTION	MAX PSI	GASKET	LOT QTY
75A1/2	3/4" MALE ADAPTER X 1/2" FEMALE THREAD	225	N/A	10/BAG
75B1/2	3/4" FEMALE COUPLER X 1/2" MALE THREAD	300	EPDM	10/BAG
050C	3/4" FEMALE COUPLER X 1/2" HOSE BARB	300	EPDM	10/BAG
050D	3/4" FEMALE COUPLER X 1/2" FEMALE THREAD	300	EPDM	10/BAG
050E	3/4" MALE ADAPTER X 1/2" HOSE BARB	300	N/A	10/BAG
050F	3/4" MALE ADAPTER X 1/2" MALE THREAD	300	N/A	10/BAG
075CAP	3/4" CAP X MALE ADAPTER	300	EPDM	10/BAG
75PL	3/4" PLUG X FEMALE COUPLER	300	N/A	10/BAG



**WARNING!** Couplings should not be disconnected under pressure or with liquid in the line.

# CAM LEVER COUPLINGS

## 1/4"-4" POLYPROPYLENE

### FEATURES

- Stainless steel rings, arms and pins
- Versatile — interchangeable with all types of cam lever couplings
- Precision molded — ensures a uniform and accurate fit
- Durable — polypropylene is glass reinforced for rugged strength
- Smooth operating — finger rings are designed for easy opening of cam levers
- Economical and superior in performance
- Standard with EPDM gaskets, FKM gaskets can be ordered separately on page 79
- Parts must be ordered in lot quantities.
- 1/4", 3/8" and 1/2" series couplings interchange with 3/4" size couplings. Coupling ends are 3/4" size.
- 1 1/4" series couplings interchange with 1" size couplings. Coupling ends are 1" size.
- 1 1/2" x 1 1/4" couplings interchange with 1 1/2" size couplings. Coupling ends are 1 1/2" size.



**WARNING!** Couplings should not be disconnected under pressure or with liquid in the line.

### 3/4" SERIES POLY CAM LEVER COUPLINGS

PART NO	DESCRIPTION	MAX PSI	GASKET	LOT QTY
75A3/4	3/4" MALE ADAPTER X 3/4" FEMALE THREAD	225	N/A	10/BAG
75B3/4	3/4" FEMALE COUPLER X 3/4" MALE THREAD	300	EPDM	10/BAG
075C	3/4" FEMALE COUPLER X 3/4" HOSE BARB	300	EPDM	10/BAG
075D	3/4" FEMALE COUPLER X 3/4" FEMALE THREAD	300	EPDM	10/BAG
075E	3/4" MALE ADAPTER X 3/4" HOSE BARB	300	N/A	10/BAG
075F	3/4" MALE ADAPTER X 3/4" MALE THREAD	300	N/A	10/BAG
075CAP	3/4" CAP X MALE ADAPTER	300	EPDM	10/BAG
75PL	3/4" PLUG X FEMALE COUPLER	300	N/A	10/BAG



### 1" SERIES POLY CAM LEVER COUPLINGS

PART NO	DESCRIPTION	MAX PSI	GASKET	LOT QTY
100A	1" MALE ADAPTER X 1" FEMALE THREAD	300	N/A	10/BAG
100B	1" FEMALE COUPLER X 1" MALE THREAD	300	EPDM	10/BAG
100C	1" FEMALE COUPLER X 1" HOSE BARB	300	EPDM	10/BAG
100D	1" FEMALE COUPLER X 1" FEMALE THREAD	300	EPDM	10/BAG
100E	1" MALE ADAPTER X 1" HOSE BARB	300	N/A	10/BAG
100F	1" MALE ADAPTER X 1" MALE THREAD	300	N/A	10/BAG
100125CAP	1" CAP X MALE ADAPTER	300	EPDM	10/BAG
100125PL	1" PLUG X FEMALE COUPLER	300	N/A	10/BAG
M100A	1" FLANGE X 1" MALE ADAPTER	300	10/BAG	



### 1 1/4" SERIES POLY CAM LEVER COUPLINGS

PART NO	DESCRIPTION	MAX PSI	GASKET	LOT QTY
125A	1" MALE ADAPTER X 1 1/4" FEMALE THREAD	300	N/A	10/BAG
125B	1" FEMALE COUPLER X 1 1/4" MALE THREAD	300	EPDM	10/BAG
125C	1" FEMALE COUPLER X 1 1/4" HOSE BARB	300	EPDM	10/BAG
125D	1" FEMALE COUPLER X 1 1/4" FEMALE THREAD	300	EPDM	10/BAG
125E	1" MALE ADAPTER X 1 1/4" HOSE BARB	300	N/A	10/BAG
125F	1" MALE ADAPTER X 1 1/4" MALE THREAD	300	N/A	10/BAG
100125CAP	1" CAP X MALE ADAPTER	300	EPDM	10/BAG
100125PL	1" PLUG X FEMALE COUPLER	300	N/A	10/BAG



### 1 1/2" X 1 1/4" SERIES POLY CAM LEVER COUPLINGS

PART NO	DESCRIPTION	MAX PSI	GASKET	LOT QTY
150125A	1 1/2" MALE ADAPTER X 1 1/4" FEMALE THREAD	225	N/A	10/BAG
150125B	1 1/2" FEMALE COUPLER X 1 1/4" MALE THREAD	300	EPDM	10
150125C	1 1/2" FEMALE COUPLER X 1 1/4" HOSE BARB	300	EPDM	10
150125D	1 1/2" FEMALE COUPLER X 1 1/4" FEMALE THREAD	300	EPDM	10
150125E	1 1/2" MALE ADAPTER X 1 1/4" HOSE BARB	225	EPDM	10/BAG
150125F	1 1/2" MALE ADAPTER X 1 1/4" MALE THREAD	300	N/A	10/BAG
150CAP	1 1/2" CAP X MALE ADAPTER	300	EPDM	10
150PL	1 1/2" PLUG X FEMALE COUPLER	225	N/A	10/BAG



### 1 1/2" SERIES POLY CAM LEVER COUPLINGS

PART NO	DESCRIPTION	MAX PSI	GASKET	LOT QTY
150A	1 1/2" MALE ADAPTER X 1 1/2" FEMALE THREAD	225	N/A	10/BAG
150B	1 1/2" FEMALE COUPLER X 1 1/2" MALE THREAD	300	EPDM	10
150C	1 1/2" FEMALE COUPLER X 1 1/2" HOSE BARB	300	EPDM	10
150D	1 1/2" FEMALE COUPLER X 1 1/2" FEMALE THREAD	300	EPDM	10
150E	1 1/2" MALE ADAPTER X 1 1/2" HOSE BARB	200	N/A	10/BAG
150F	1 1/2" MALE ADAPTER X 1 1/2" MALE THREAD	300	N/A	10/BAG
150CAP	1 1/2" CAP X MALE ADAPTER	300	EPDM	10
150PL	1 1/2" PLUG X FEMALE COUPLER	225	N/A	10/BAG



# CAM LEVER COUPLINGS

## 2" SERIES POLY CAM LEVER COUPLINGS

PART NO	DESCRIPTION	MAX PSI	GASKET	LOT QTY
200A	2" MALE ADAPTER X 2" FEMALE THREAD	225	N/A	10/BAG
200B	2" FEMALE COUPLER X 2" MALE THREAD	225	EPDM	10/BAG
201B	2" FEMALE COUPLER X 2" EXTENDED MALE THREAD	200	EPDM	10/BAG
200C	2" FEMALE COUPLER X 2" HOSE BARB	225	EPDM	10/BAG
200D	2" FEMALE COUPLER X 2" FEMALE THREAD	200	EPDM	10/BAG
200E	2" MALE ADAPTER X 2" HOSE BARB	200	N/A	10/BAG
200F	2" MALE ADAPTER X 2" MALE THREAD	300	N/A	10/BAG
200CAP	2" CAP X MALE ADAPTER	200	EPDM	10/BAG
200CAPSH	2" CAP X MALE ADAPTER W/SHORT ARMS	200	EPDM	10/BAG
200PL	2" PLUG X FEMALE COUPLER	225	N/A	10/BAG
M200A	2" FLANGE X 2" MALE ADAPTER	300	N/A	10/BAG
M220A	2" FP FLANGE X 2" MALE ADAPTER	225	N/A	10/BAG
M220D	2" FP FLANGE X FEMALE COUPLER	225	EPDM	10/BAG



## 2" X 1/2" SERIES POLY CAM LEVER COUPLINGS

PART NO	DESCRIPTION	MAX PSI	GASKET	LOT QTY
200150C	2" FEMALE COUPLER X 1/2" HOSE BARB	300	EPDM	10

## 2 1/2" SERIES POLY CAM LEVER COUPLINGS

PART NO	DESCRIPTION	MAX PSI	GASKET	QTY
250CAP	2 1/2" CAP X MALE ADAPTER	300	EPDM	1
250PL	2 1/2" PLUG X FEMALE COUPLER	300	N/A	1

## 3" SERIES POLY CAM LEVER COUPLINGS

PART NO	DESCRIPTION	MAX PSI	GASKET	LOT QTY
300A	3" MALE ADAPTER X 3" FEMALE THREAD	75	N/A	1
300B	3" FEMALE COUPLER X 3" MALE THREAD	150	EPDM	1
303B	3" FEMALE COUPLER X 3" EXTENDED MALE THREAD	200	EPDM	10
303B200A	3" FEMALE COUPLER W/ 3 ARMS X 2" MALE ADAPTER	200	EPDM	10
300C	3" FEMALE COUPLER X 3" HOSE BARB	200	EPDM	1
303C	3" FEMALE COUPLER W/ 3 ARMS X 3" HOSE BARB	200	EPDM	10
300D	3" FEMALE COUPLER X 3" FEMALE THREAD	200	EPDM	1
300E	3" MALE ADAPTER X 3" HOSE BARB	150	N/A	1
300F	3" MALE ADAPTER X 3" MALE THREAD	100	N/A	1
300CAP	3" CAP X MALE ADAPTER	100	EPDM	1
300PL	3" PLUG X FEMALE COUPLER	150	N/A	1
M300A	3" FP FLANGE X 3" MALE ADAPTER	100	N/A	1
M303D	3" FP FLANGE X 3" FEMALE COUPLER W/3 ARMS	225	EPDM	10/BAG



## 4" SERIES POLY CAM LEVER COUPLINGS

PART NO	DESCRIPTION	MAX PSI	GASKET	LOT QTY
400A	4" MALE ADAPTER X 4" FEMALE THREAD	75	N/A	1
400B	4" FEMALE COUPLER X 4" MALE THREAD	150	EPDM	1
400C	4" FEMALE COUPLER X 4" HOSE BARB	150	EPDM	1
400D	4" FEMALE COUPLER X 4" FEMALE THREAD	100	EPDM	1
400E	4" MALE ADAPTER X 4" HOSE BARB	50	N/A	1
400F	4" MALE ADAPTER X 4" MALE THREAD	75	N/A	1
400CAP	4" CAP X MALE ADAPTER (W/2 ARMS)	100	EPDM	1
400PL	4" PLUG X FEMALE COUPLER	75	N/A	1



## 1/4"-4" POLYPROPYLENE

### FEATURES

- Stainless steel rings, arms and pins
- Versatile — interchangeable with all types of cam lever couplings
- Precision molded — ensures a uniform and accurate fit
- Durable — polypropylene is glass reinforced for rugged strength
- Smooth operating — finger rings are designed for easy opening of cam levers
- Economical and superior in performance
- Parts must be ordered in lot quantities.
- 1/4", 3/8" and 1/2" series couplings interchange with 3/4" size couplings. Coupling ends are 3/4" size.
- 1 1/4" series couplings interchange with 1" size couplings. Coupling ends are 1" size.
- 1 1/2" x 1 1/4" couplings interchange with 1 1/2" size couplings. Coupling ends are 1 1/2" size.



**WARNING!** Couplings should not be disconnected under pressure or with liquid in the line.

# CAM LEVER COUPLINGS

¼"-4" POLYPROPYLENE

## FEATURES

- Chemical resistant to protect against corrosion
- Versatile to interchange with all types of cam lever couplings
- Smooth operation makes connections quick and easy
- Parts must be ordered in lot quantities.
- Locking cam arm lever is not intended to be used as a security device or prevent unauthorized opening of coupling assembly.



**WARNING!** Couplings should not be disconnected under pressure or with liquid in the line.

EASY ACTION  
LOCKING LEVER!



EPDM



FKM

LOCKING ARM  
WITH RING



PIN



## 1½" - 2" SERIES LOCKING POLY CAM LEVER COUPLINGS

PART NO	DESCRIPTION	MAX PSI	GASKET	QTY
L200B	2" FEMALE COUPLER X 2" MALE THREAD	225	EPDM	1
L200C	2" FEMALE COUPLER X 2" HOSE BARB	225	EPDM	1
L200D	2" FEMALE COUPLER X 2" FEMALE THREAD	200	EPDM	1
L200CAP	2" CAP X MALE ADAPTER	200	EPDM	1

## SPOOL ADAPTERS

PART NO	DESCRIPTION	MAX PSI	GASKET	LOT QTY
200FF	2" MALE ADAPTER X 2" MALE ADAPTER	150	N/A	10/BAG
300F200F	3" MALE ADAPTER X 2" MALE ADAPTER	75	N/A	1
300FF	3" MALE ADAPTER X 3" MALE ADAPTER	75	N/A	1

## REPLACEMENT PARTS

PART NO	DESCRIPTION	LOT QTY
100RING	RING FITS ¾" & 1"	10
150RING	RING FITS 1½", 2", 3", 4"	10
150(200)K	1½", 2" SS CAM ARM W/RING	1
300K	3" SS CAM ARM WITH RING	1
V20207	11" LANYARD	25
75G	½" & ¾" EPDM GASKET	25
75GV	¾" FKM GASKET	10
100G	1" & 1¼" EPDM GASKET	25
100GV	1" & 1¼" FKM GASKET	10
150G	1½" EPDM GASKET	25
150GV	1½" FKM GASKET	10
200G	2" EPDM GASKET	25
200GV	2" FKM GASKET	10
300G	3" EPDM GASKET	25
300GV	3" FKM GASKET	10
400G	4" EPDM GASKET	1
200KL	2" LOCKING CAM ARM WITH RING FITS 1½" & 2"	1
200PKL	2" COUPLING PIN FITS 1½" & 2"	1
200P	2" COUPLING PIN	1
300P	3" COUPLING PIN	1

# CAM LEVER COUPLINGS

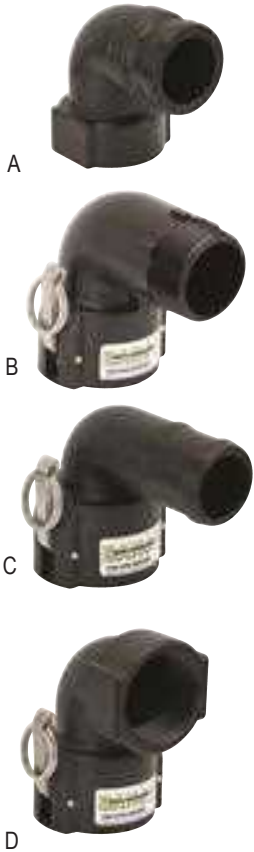

1 1/2" 90° POLY CAM LEVER COUPLINGS				
PART NO	DESCRIPTION	MAX PSI	GASKET	LOT QTY
150A90	1 1/2" 90° MALE ADAPTER X 1 1/2" FEMALE THREAD	225	N/A	10/BAG
150C90	1 1/2" 90° FEMALE COUPLER X 1 1/2" HOSE BARB	225	EPDM	10
150D90	1 1/2" 90° FEMALE COUPLER X 1 1/2" FEMALE THREAD	300	EPDM	10
150F90	1 1/2" 90° MALE ADAPTER X 1 1/2" MALE THREAD	300	N/A	10/BAG

2" 90° SERIES POLY CAM LEVER COUPLINGS				
PART NO	DESCRIPTION	MAX PSI	GASKET	LOT QTY
200A90	2" 90° MALE ADAPTER X 2" FEMALE THREAD	225	N/A	10/BAG
200B90	2" 90° FEMALE COUPLER X 2" MALE THREAD	225	EPDM	10
200C90	2" 90° FEMALE COUPLER X 2" HOSE BARB	225	EPDM	10
200D90	2" 90° FEMALE COUPLER X 2" FEMALE THREAD	200	EPDM	10
200F90	2" 90° MALE ADAPTER X 2" MALE THREAD	225	N/A	10/BAG

2" 45° POLY CAM LEVER COUPLINGS				
PART NO	DESCRIPTION	MAX PSI	GASKET	LOT QTY
200F45	2" 45° MALE ADAPTER X 2" MALE THREAD	225	N/A	10/BAG

2" 45° POLY CAM LEVER COUPLINGS				
PART NO	DESCRIPTION	MAX PSI	GASKET	LOT QTY
M220ASWP90	2" FP FLANGE X MALE ADAPTER SWEEP	200	N/A	10/BAG
M300ASWP90	3" FP FLANGE X MALE ADAPTER SWEEP	100	N/A	1



GARDEN HOSE FITTINGS			
PART NO	DESCRIPTION	MAX PSI	LOT QTY
GHFT075A	3/4" ADAPTER X 3/4" GARDEN HOSE FEMALE THREAD	225	10/BAG
GHMT075B	3/4" COUPLER X 3/4" GARDEN HOSE MALE THREAD	300	10/BAG
GHFT075D	3/4" COUPLER X 3/4" GARDEN HOSE FEMALE THREAD	300	10/BAG
GHMT075F	3/4" ADAPTER X 3/4" GARDEN HOSE MALE THREAD	300	10/BAG
GHFT075MPT	3/4" MALE NPT X 3/4" GARDEN HOSE FEMALE THREAD	300	10/BAG
GHMT075FPT	3/4" FEMALE NPT X 3/4" GARDEN HOSE MALE THREAD	300	10/BAG
GHMT075MPT	3/4" MALE NPT X 3/4" GARDEN HOSE MALE THREAD	300	10/BAG
GHFT075G	3/4" GARDEN HOSE FITTING GASKET	N/A	25

GARDEN HOSE NOZZLE			
PART NO	DESCRIPTION	MAX PSI	QTY
GHN075	3/4" GARDEN HOSE SPRAY NOZZLE	N/A	1



Spray nozzle patterns

## 1 1/2"-2" 90° & 45° POLYPROPYLENE

### FEATURES

- Precision molded in polypropylene, reinforced with fiberglass for strength
- Stainless steel rings, arms and pins resist corrosion
- 90° angle couplings and adapters will reduce the number of elbows and other pipe fittings used in plumbing applications



**WARNING!** Couplings should not be disconnected under pressure or with liquid in the line.

## GARDEN HOSE FITTINGS & NOZZLE

- Same construction and design that farmers use for their heavy spraying applications.
- Rugged, secure quick-connect cam arms
- Heavy-duty thick wall reinforced polypropylene
- Proven, leak-free construction
- Full flow design

### FEATURES

- Heavy duty machined aluminum construction stands up to hard use
- Comfort grip soft rubber
- Resists dents, mars and scratches; protects any surface that comes in contact with nozzle
- Aluminum hose connection provides a tight fit, will not rust
- Multiple spray pattern adjusts from a powerful jet stream to a gentle fan spray. Ideal for all your spraying needs.
- Stainless steel spray cap for precise spray patterns



# PIPE FITTINGS

## SUPER CLAMPS

### FEATURES

- Stainless steel construction
- 304 stainless steel bolt with 316 stainless steel nut to prevent seizing
- 360° sealing surface
- Ideal for high torque applications
- Strong, positive connections where ordinary hose clamps fail
- T-bolt design
- 3 spot welds for extra strength
- Sold in bags of 10 only
- Torque specifications: working torque 50-80 inch pounds, maximum torque 125 inch pounds
- Please note new Min-Max Diameter measurements.



### SUPER CLAMPS

PART NO	DESCRIPTION	MIN-MAX DIAMETER	MAX TORQUE	LOT QTY
TC120	1" T-BOLT HOSE CLAMP	1.18"-1.34"	75 IN-LBS	10/BAG
TC130	1¼" T-BOLT HOSE CLAMP	1.34"-1.50"	75 IN-LBS	10/BAG
TC150	1½" T-BOLT HOSE CLAMP	1.50"-1.62"	75 IN-LBS	10/BAG
TC162	1¾" T-BOLT HOSE CLAMP	1.59"-1.87"	75 IN-LBS	10/BAG
TC181	1½" T-BOLT HOSE CLAMP	1.84"-2.12"	75 IN-LBS	10/BAG
TC193	1½" T-BOLT HOSE CLAMP	1.90"-2.24"	75 IN-LBS	10/BAG
TC206	2" T-BOLT HOSE CLAMP	2.16"-2.40"	75 IN-LBS	10/BAG
TC218	2" T-BOLT HOSE CLAMP	2.18"-2.52"	75 IN-LBS	10/BAG
TC224	2" T-BOLT HOSE CLAMP	2.24"-2.58"	75 IN-LBS	10/BAG
TC231	2" T-BOLT HOSE CLAMP	2.31"-2.65"	75 IN-LBS	10/BAG
TC250	2" T-BOLT HOSE CLAMP	2.50"-2.84"	75 IN-LBS	10/BAG
TC287	2" T-BOLT HOSE CLAMP	2.87"-3.18"	75 IN-LBS	10/BAG
TC312	3" T-BOLT HOSE CLAMP	3.28"-3.50"	75 IN-LBS	10/BAG
TC331	3" T-BOLT HOSE CLAMP	3.31"-3.70"	75 IN-LBS	10/BAG
TC343	3" T-BOLT HOSE CLAMP	3.50"-3.89"	75 IN-LBS	10/BAG
TC425	4" T-BOLT HOSE CLAMP	4.25"-4.64"	75 IN-LBS	10/BAG
TC438	4" T-BOLT HOSE CLAMP	4.38"-4.69"	180 IN-LBS	10/BAG
TC456	4" T-BOLT HOSE CLAMP	4.56"-4.87"	180 IN-LBS	10/BAG



## NIPPLES

PART NO	DESCRIPTION	MAX PSI	LOT QTY
NIP025-SH	1/4" SHORT POLY NIPPLE	300	10/BAG
NIP038-SH	3/8" SHORT POLY NIPPLE	300	10/BAG
NIP050-SH	1/2" SHORT POLY NIPPLE	300	10/BAG
NIP050-3	1/2" X 3" POLY NIPPLE	300	10/BAG
NIP075-SH	3/4" SHORT POLY NIPPLE	300	10/BAG
NIP075-4	3/4" X 4" POLY NIPPLE	300	10/BAG
NIP075-6	3/4" X 6" POLY NIPPLE	300	10/BAG
NIP100-SH	1" SHORT POLY NIPPLE	300	10/BAG
NIP100-4	1" X 4" POLY NIPPLE	300	10/BAG
NIP100-6	1" X 6" POLY NIPPLE	300	10/BAG
NIP125-SH	1 1/4" SHORT POLY NIPPLE	300	10/BAG
NIP125-4	1 1/4" X 4" POLY NIPPLE	300	10/BAG
NIP125-6	1 1/4" X 6" POLY NIPPLE	300	10/BAG
NIP150-SH	1 1/2" SHORT POLY NIPPLE	300	10/BAG
NIP150-3	1 1/2" X 3" POLY NIPPLE	300	10/BAG
NIP150-4	1 1/2" X 4" POLY NIPPLE	300	10/BAG
NIP150-5	1 1/2" X 5" POLY NIPPLE	300	10/BAG
NIP150-6	1 1/2" X 6" POLY NIPPLE	300	10/BAG
NIP200-SH	2" SHORT POLY NIPPLE	300	10/BAG
NIP200-4	2" X 4" POLY NIPPLE	300	10/BAG
NIP200-6	2" X 6" POLY NIPPLE	300	10/BAG
NIP300-SH	3" SHORT POLY NIPPLE	300	1
NIP300-4	3" X 4" POLY NIPPLE	300	1
NIP300-6	3" X 6" POLY NIPPLE	300	1
NIP400-SH	4" SHORT POLY NIPPLE	300	1



## REDUCING NIPPLES

PART NO	DESCRIPTION	MAX PSI	LOT QTY
RN050-038	1/2" X 3/8" POLY REDUCING NIPPLE	300	10/BAG
RN075-050	3/4" X 1/2" POLY REDUCING NIPPLE	300	10/BAG
RN100-050	1" X 1/2" POLY REDUCING NIPPLE	300	10/BAG
RN100-075	1" X 3/4" POLY REDUCING NIPPLE	300	10/BAG
RN125-075	1 1/4" X 3/4" POLY REDUCING NIPPLE	300	10/BAG
RN125-100	1 1/4" X 1" POLY REDUCING NIPPLE	300	10/BAG
RN150-100	1 1/2" X 1" POLY REDUCING NIPPLE	300	10/BAG
RN150-125	1 1/2" X 1 1/4" POLY REDUCING NIPPLE	300	10/BAG
RN200-125	2" X 1 1/4" POLY REDUCING NIPPLE	300	10/BAG
RN200-150	2" X 1 1/2" POLY REDUCING NIPPLE	300	10/BAG
RN300-200	3" X 2" POLY REDUCING NIPPLE	300	1



## PIPE COUPLINGS

PART NO	DESCRIPTION	MAX PSI	LOT QTY
CPLG025	1/4" POLY PIPE COUPLING	300	10/BAG
CPLG038	3/8" POLY PIPE COUPLING	300	10/BAG
CPLG050	1/2" POLY PIPE COUPLING	300	10/BAG
CPLG075	3/4" POLY PIPE COUPLING	300	10/BAG
CPLG100	1" POLY PIPE COUPLING	300	10/BAG
CPLG125	1 1/4" POLY PIPE COUPLING	300	10/BAG
CPLG150	1 1/2" POLY PIPE COUPLING	300	10/BAG
CPLG200	2" POLY PIPE COUPLING	300	10/BAG
CPLG300	3" POLY PIPE COUPLING	225	1



## REDUCING COUPLINGS

PART NO	DESCRIPTION	MAX PSI	LOT QTY
RC100-075	1" X 3/4" POLY REDUCING COUPLING	300	10/BAG
RC150-100	1 1/2" X 1" POLY REDUCING COUPLING	300	10/BAG
RC150-125	1 1/2" X 1 1/4" POLY REDUCING COUPLING	300	10/BAG
RC200-050	2" X 1/2" POLY REDUCING COUPLING	300	10/BAG
RC200-100	2" X 1" POLY REDUCING COUPLING	300	10/BAG
RC200-125	2" X 1 1/4" POLY REDUCING COUPLING	300	10/BAG
RC200-150	2" X 1 1/2" POLY REDUCING COUPLING	300	10/BAG
RC300-200	3" X 2" POLY REDUCING COUPLING	300	5

## REDUCING BUSHINGS

PART NO	DESCRIPTION	MAX PSI	LOT QTY
RB038-025	3/8" MPT X 1/4" FPT REDUCING BUSHING	300	10/BAG
RB050-018	1/2" MPT X 1/8" FPT REDUCING BUSHING	300	10/BAG
RB050-025	1/2" MPT X 1/4" FPT REDUCING BUSHING	300	10/BAG
RB050-038	1/2" MPT X 3/8" FPT REDUCING BUSHING	300	10/BAG
RB075-018	3/4" MPT X 1/8" FPT REDUCING BUSHING	300	10/BAG
RB075-025	3/4" MPT X 1/4" FPT REDUCING BUSHING	300	10/BAG
RB075-038	3/4" MPT X 3/8" FPT REDUCING BUSHING	300	10/BAG
RB075-050	3/4" MPT X 1/2" FPT REDUCING BUSHING	300	10/BAG
RB100-018	1" MPT X 1/8" FPT REDUCING BUSHING	300	10/BAG
RB100-025	1" MPT X 1/4" FPT REDUCING BUSHING	300	10/BAG
RB100-050	1" MPT X 1/2" FPT REDUCING BUSHING	300	10/BAG
RB100-075	1" MPT X 3/4" FPT REDUCING BUSHING	300	10/BAG
RB125-038	1" MPT X 3/8" FPT REDUCING BUSHING	300	10/BAG
RB125-075	1 1/4" MPT X 3/4" FPT REDUCING BUSHING	300	10/BAG
RB125-100	1 1/4" MPT X 1" FPT REDUCING BUSHING	300	10/BAG
RB150-075	1 1/2" MPT X 3/4" FPT REDUCING BUSHING	300	10/BAG
RB150-100	1 1/2" MPT X 1" FPT REDUCING BUSHING	300	10/BAG
RB150-125	1 1/2" MPT X 1 1/4" FPT REDUCING BUSHING	300	10/BAG
RB200-075	2" MPT X 3/4" FPT REDUCING BUSHING	300	10/BAG
RB200-100	2" MPT X 1" FPT REDUCING BUSHING	300	10/BAG
RB200-125	2" MPT X 1 1/4" FPT REDUCING BUSHING	300	10/BAG
RB200-150	2" MPT X 1 1/2" FPT REDUCING BUSHING	300	10/BAG
RB300-150	3" MPT X 1 1/2" FPT REDUCING BUSHING	300	1
RB300-200	3" MPT X 2" FPT REDUCING BUSHING	300	1
RB400-300	4" MPT X 3" FPT REDUCING BUSHING	300	1

## PIPE FITTINGS

### FEATURES

- Glass reinforced polypropylene
- Heavy duty (Schedule 80)
- Lightweight with excellent strength
- NPT threads
- Excellent chemical resistance
- Parts must be ordered in lot quantities.



# PIPE FITTINGS

## PIPE FITTINGS

### FEATURES

- Glass reinforced polypropylene
- Heavy duty (Schedule 80)
- Lightweight with excellent strength
- NPT threads
- Excellent chemical resistance
- Parts must be ordered in lot quantities.



### PIPE CAPS

PART NO	DESCRIPTION	MAX PSI	LOT QTY
CAP038	3/8" POLY PIPE CAP	300	10/BAG
CAP050	1/2" POLY PIPE CAP	300	10/BAG
CAP075	3/4" POLY PIPE CAP	300	10/BAG
CAP100	1" POLY PIPE CAP	300	10/BAG
CAP125	1 1/4" POLY PIPE CAP	300	10/BAG
CAP150	1 1/2" POLY PIPE CAP	300	10/BAG
CAP200	2" POLY PIPE CAP	300	10/BAG
CAP300	3" POLY PIPE CAP	300	1



### CROSSES

PART NO	DESCRIPTION	MAX PSI	LOT QTY
CR025	1/4" POLY CROSS	300	10/BAG
CR038	3/8" POLY CROSS	300	10/BAG
CR050	1/2" POLY CROSS	300	10/BAG
CR075	3/4" POLY CROSS	300	10/BAG
CR100	1" POLY CROSS	300	10/BAG
CR125	1 1/4" POLY CROSS	300	10/BAG
CR150	1 1/2" POLY CROSS	300	10
CR200	2" POLY CROSS	300	10



### PIPE PLUGS

PART NO	DESCRIPTION	MAX PSI	LOT QTY
PLUG025	1/4" POLY PIPE PLUG	300	10/BAG
PLUG038	3/8" POLY PIPE PLUG	300	10/BAG
PLUG050	1/2" POLY PIPE PLUG	300	10/BAG
PLUG075	3/4" POLY PIPE PLUG	300	10/BAG
PLUG100	1" POLY PIPE PLUG	300	10/BAG
PLUG125	1 1/4" POLY PIPE PLUG	300	10/BAG
PLUG150	1 1/2" POLY PIPE PLUG	300	10/BAG
PLUG200	2" POLY PIPE PLUG	300	10/BAG
PLUG300	3" POLY PIPE PLUG	300	1



### TEES

PART NO	DESCRIPTION	MAX PSI	LOT QTY
TEE025	1/4" POLY TEE	300	10/BAG
TEE038	3/8" POLY TEE	300	10/BAG
TEE050	1/2" POLY TEE	300	10/BAG
TEE075	3/4" POLY TEE	300	10/BAG
TEE100	1" POLY TEE	300	10/BAG
TEE125	1 1/4" POLY TEE	300	10/BAG
TEE150	1 1/2" POLY TEE	300	10/BAG
TEE200	2" POLY TEE	300	10
TEE300	3" POLY TEE	225	1



### HOSE BARB CROSS

PART NO	DESCRIPTION	MAX PSI	LOT QTY
HBC050075	1/2" X 3/4" HOSE BARB CROSS	300	10/BAG



### GAUGE PORT TEE

PART NO	DESCRIPTION	MAX PSI	LOT QTY
TEG075	3/4" POLY TEE W/ 1/4" FEMALE THREAD	300	10/BAG
TEG100	1" POLY TEE W/ 1/4" FEMALE THREAD	300	10/BAG

## PIPE FITTINGS



### 90° ELBOWS

PART NO	DESCRIPTION	MAX PSI	LOT QTY
EL025-90	1/4" 90° POLY ELBOW	300	10/BAG
EL038-90	3/8" 90° POLY ELBOW	300	10/BAG
EL050-90	1/2" 90° POLY ELBOW	300	10/BAG
EL075-90	3/4" 90° POLY ELBOW	300	10/BAG
EL100-90	1" 90° POLY ELBOW	300	10/BAG
EL125-90	1 1/4" 90° POLY ELBOW	300	10/BAG
EL150-90	1 1/2" 90° POLY ELBOW	300	10/BAG
EL200-90	2" 90° POLY ELBOW	300	10/BAG
EL300-90	3" 90° POLY ELBOW	300	1



### 45° STREET ELBOWS

PART NO	DESCRIPTION	MAX PSI	LOT QTY
SL075-45	3/4" 45° POLY STREET ELBOW	300	10/BAG
SL100-45	1" 45° POLY STREET ELBOW	300	10/BAG
SL125-45	1 1/4" 45° POLY STREET ELBOW	300	10/BAG
SL150-45	1 1/2" 45° POLY STREET ELBOW	300	10/BAG
SL200-45	2" 45° POLY STREET ELBOW	225	10/BAG
SL300-45	3" 45° POLY STREET ELBOW	300	1

### FEATURES

- Glass reinforced polypropylene
- Heavy duty (Schedule 80)
- Lightweight with excellent strength
- NPT threads
- Excellent chemical resistance
- Parts must be ordered in lot quantities.



### 45° ELBOW

PART NO	DESCRIPTION	MAX PSI	LOT QTY
EL100-45	1" 45° POLY ELBOW	300	10/BAG



### 90° HOSE BARB ELBOW

PART NO	DESCRIPTION	MAX PSI	LOT QTY
HBB20012590	2" X 1 1/4" 90° POLY HOSE BARB ELBOW	300	10/BAG



### 90° STREET ELBOWS

PART NO	DESCRIPTION	MAX PSI	LOT QTY
SL025-90	1/4" 90° POLY STREET ELBOW	300	10/BAG
SL038-90	3/8" 90° POLY STREET ELBOW	300	10/BAG
SL050-90	1/2" 90° POLY STREET ELBOW	300	10/BAG
SL075-90	3/4" 90° POLY STREET ELBOW	300	10/BAG
SL100-90	1" 90° POLY STREET ELBOW	300	10/BAG
SL125-90	1 1/4" 90° POLY STREET ELBOW	300	10/BAG
SL150-90	1 1/2" 90° POLY STREET ELBOW	300	10/BAG
SL200-90	2" 90° POLY STREET ELBOW	300	10/BAG
SL300-90	3" 90° POLY STREET ELBOW	300	1



### 90° HOSE BARB ELBOW

PART NO	DESCRIPTION	MAX PSI	LOT QTY
HBEL100-90	1" 90° POLY HOSE BARB ELBOW	300	10/BAG
HBEL150/100-90	1 1/2" X 1" 90° POLY HOSE BARB ELBOW	300	10/BAG

# PIPE FITTINGS

## HOSE BARBS



### FEATURES

- Glass reinforced polypropylene
- Heavy duty (Schedule 80)
- Lightweight with excellent strength
- NPT threads
- Excellent chemical resistance
- Parts must be ordered in lot quantities.

### STRAIGHT HOSE BARBS

PART NO	DESCRIPTION	MAX PSI	LOT QTY
HB025	1/4" MALE THREAD X 1/4" HOSE BARB	300	10/BAG
HB025-038	1/4" MALE THREAD X 3/8" HOSE BARB	300	10/BAG
HB025-050	1/4" MALE THREAD X 1/2" HOSE BARB	300	10/BAG
HB038	3/8" MALE THREAD X 3/8" HOSE BARB	300	10/BAG
HB038-025	3/8" MALE THREAD X 1/4" HOSE BARB	300	10/BAG
HB038-050	3/8" MALE THREAD X 1/2" HOSE BARB	300	10/BAG
HB050-025	1/2" MALE THREAD X 1/4" HOSE BARB	300	10/BAG
HB050-038	1/2" MALE THREAD X 3/8" HOSE BARB	300	10/BAG
HB050	1/2" MALE THREAD X 1/2" HOSE BARB	300	10/BAG
HB050-075	1/2" MALE THREAD X 3/4" HOSE BARB	300	10/BAG
HB075-038	3/4" MALE THREAD X 3/8" HOSE BARB	300	10/BAG
HB075-050	3/4" MALE THREAD X 1/2" HOSE BARB	300	10/BAG
HB075-058	3/4" MALE THREAD X 5/8" HOSE BARB	300	10/BAG
HB075	3/4" MALE THREAD X 3/4" HOSE BARB	300	10/BAG
HB075-100	3/4" MALE THREAD X 1" HOSE BARB	300	10/BAG
HB100-075	1" MALE THREAD X 3/4" HOSE BARB	300	10/BAG
HB100	1" MALE THREAD X 1" HOSE BARB	300	10/BAG
HB100-125	1" MALE THREAD X 1 1/4" HOSE BARB	300	10/BAG
HB125-075	1 1/4" MALE THREAD X 3/4" HOSE BARB	300	10/BAG
HB125-100	1 1/4" MALE THREAD X 1" HOSE BARB	300	10/BAG
HB125	1 1/4" MALE THREAD X 1 1/4" HOSE BARB	300	10/BAG
HB125-150	1 1/4" MALE THREAD X 1 1/2" HOSE BARB	300	10/BAG
HB150-100	1 1/2" MALE THREAD X 1" HOSE BARB	300	10/BAG
HB150-125	1 1/2" MALE THREAD X 1 1/4" HOSE BARB	300	10/BAG
HB150	1 1/2" MALE THREAD X 1 1/2" HOSE BARB	300	10/BAG
HB150-200	1 1/2" MALE THREAD X 2" HOSE BARB	300	10/BAG
HB200-150	2" MALE THREAD X 1 1/2" HOSE BARB	300	10/BAG
HB200	2" MALE THREAD X 2" HOSE BARB	300	10/BAG
HB300	3" MALE THREAD X 3" HOSE BARB	225	1
HB400	4" MALE THREAD X 4" HOSE BARB	150	1

### 90° HOSE BARBS

PART NO	DESCRIPTION	MAX PSI	LOT QTY
HB025-90	1/4" MALE THREAD X 1/4" 90° HOSE BARB	300	10/BAG
HB025/038-90	1/4" MALE THREAD X 3/8" 90° HOSE BARB	300	10/BAG
HB025/050-90	1/4" MALE THREAD X 1/2" 90° HOSE BARB	300	10/BAG
HB038-90	3/8" MALE THREAD X 3/8" 90° HOSE BARB	300	10/BAG
HB038/050-90	3/8" MALE THREAD X 1/2" 90° HOSE BARB	300	10/BAG
HB050-90	1/2" MALE THREAD X 1/2" 90° HOSE BARB	300	10/BAG
HB050/038-90	1/2" MALE THREAD X 3/8" 90° HOSE BARB	300	10/BAG
HB050/075-90	1/2" MALE THREAD X 3/4" 90° HOSE BARB	300	10/BAG
HB075/050-90	3/4" MALE THREAD X 1/2" 90° HOSE BARB	300	10/BAG
HB075-90	3/4" MALE THREAD X 3/4" 90° HOSE BARB	300	10/BAG
HB075/100-90	3/4" MALE THREAD X 1" 90° HOSE BARB	300	10/BAG
HB100/075-90	1" MALE THREAD X 3/4" 90° HOSE BARB	300	10/BAG
HB100-90	1" MALE THREAD X 1" 90° HOSE BARB	300	10/BAG
HB100/125-90	1" MALE THREAD X 1 1/4" 90° HOSE BARB	300	10/BAG
HB125/100-90	1 1/4" MALE THREAD X 1" 90° HOSE BARB	300	10/BAG
HB125-90	1 1/4" MALE THREAD X 1 1/4" 90° HOSE BARB	300	10/BAG
HB125/150-90	1 1/4" MALE THREAD X 1 1/2" 90° HOSE BARB	300	10/BAG
HB150/125-90	1 1/2" MALE THREAD X 1 1/4" 90° HOSE BARB	300	10/BAG
HB150-90	1 1/2" MALE THREAD X 1 1/2" 90° HOSE BARB	300	10/BAG
HB200/150-90	2" MALE THREAD X 1 1/2" 90° HOSE BARB	300	10/BAG
HB200-90	2" MALE THREAD X 2" 90° HOSE BARB	300	10/BAG
HB300-90	3" MALE THREAD X 3" 90° HOSE BARB	225	1



### 316 STAINLESS STEEL HOSE BARBS

PART NO	DESCRIPTION	MAX PSI	LOT QTY
HB025SS	1/4" MALE THREAD X 1/4" HOSE BARB	300	10
HB025-038SS	1/4" MALE THREAD X 3/8" HOSE BARB	300	10
HB025-050SS	1/4" MALE THREAD X 1/2" HOSE BARB	300	10
HB038SS	3/8" MALE THREAD X 3/8" HOSE BARB	300	10
HB038-050SS	3/8" MALE THREAD X 1/2" HOSE BARB	300	10
HB050SS	1/2" MALE THREAD X 1/2" HOSE BARB	300	10
HB050-058SS	1/2" MALE THREAD X 5/8" HOSE BARB	300	1
HB050-075SS	1/2" MALE THREAD X 3/4" HOSE BARB	300	10
HB075-050SS	3/4" MALE THREAD X 1/2" HOSE BARB	300	10
HB075SS	3/4" MALE THREAD X 3/4" HOSE BARB	300	10
HB075-100SS	3/4" MALE THREAD X 1" HOSE BARB	300	1
HB100-075SS	1" MALE THREAD X 3/4" HOSE BARB	300	1
HB100SS	1" MALE THREAD X 1" HOSE BARB	300	10
HB125SS	1 1/4" MALE THREAD X 1 1/4" HOSE BARB	300	1
HB150SS	1 1/2" MALE THREAD X 1 1/2" HOSE BARB	300	10
HB200SS	2" MALE THREAD X 2" HOSE BARB	300	1
HB300SS	3" MALE THREAD X 3" HOSE BARB	300	1



### FEMALE HOSE BARBS

PART NO	DESCRIPTION	MAX PSI	LOT QTY
HBF075	3/4" FEMALE THREAD X 3/4" HOSE BARB	300	10/BAG
HBF075-90	3/4" FEMALE THREAD X 3/4" 90° HOSE BARB	300	10/BAG
HBF075-100	3/4" FEMALE THREAD X 1" HOSE BARB	300	10/BAG
HBF100	1" FEMALE THREAD X 1" HOSE BARB	300	10/BAG
HBF100-90	1" FEMALE THREAD X 1" 90° HOSE BARB	300	10/BAG



## HOSE BARB TEES

PART NO	DESCRIPTION	MAX PSI	LOT QTY
HBT025	1/4" HOSE BARB TEE	300	10/BAG
HBT038	3/8" HOSE BARB TEE	300	10/BAG
HBT050	1/2" HOSE BARB TEE	300	10/BAG
HBT050-038	1/2" X 3/8" HOSE BARB TEE	300	10/BAG
HBT050-075	1/2" X 1/2" X 3/4" HOSE BARB TEE	300	10/BAG
HBT075-050	3/4" X 3/4" X 1/2" HOSE BARB TEE	300	10/BAG
HBT075	3/4" HOSE BARB TEE	300	10/BAG
HBT075-100	3/4" X 3/4" X 1" HOSE BARB TEE	300	10/BAG
HBT100-075	1" X 1" X 3/4" HOSE BARB TEE	300	10/BAG
HBT100	1" HOSE BARB TEE	300	10/BAG
HBT200	2" HOSE BARB TEE	300	10
HBT300	3" HOSE BARB TEE	300	1



## HOSE BARB THREADED TEES

PART NO	DESCRIPTION	MAX PSI	LOT QTY
HBT100-100	1" HOSE BARB X 1" HOSE BARB X 1" MALE THREAD HOSE BARB TEE	300	10/BAG
HBT150-100	1 1/2" HOSE BARB X 1 1/2" HOSE BARB X 1" MALE THREAD HOSE BARB TEE	300	10/BAG
HBT150-150	1 1/2" HOSE BARB X 1 1/2" HOSE BARB X 1 1/2" MALE THREAD HOSE BARB TEE	300	10/BAG



## SS HOSE BARB THREADED TEES

PART NO	DESCRIPTION	MAX PSI	QTY
HBT075-050SS	3/4" HOSE BARB X 3/4" HOSE BARB X 1/2" HOSE BARB TEE	N/A	1



## HOSE MENDERS

PART NO	DESCRIPTION	MAX PSI	LOT QTY
HM038	3/8" X 3/8" HOSE BARB	300	10/BAG
HM050	1/2" X 1/2" HOSE BARB	300	10/BAG
HM075	3/4" X 3/4" HOSE BARB	300	10/BAG
HM100	1" X 1" HOSE BARB	300	10/BAG
HM125	1 1/4" X 1 1/4" HOSE BARB	300	10/BAG
HM150	1 1/2" X 1 1/2" HOSE BARB	300	10/BAG
HM200	2" X 2" HOSE BARB	300	10/BAG
HM300	3" X 3" HOSE BARB	300	1



## SWIVELS

PART NO	DESCRIPTION	MAX PSI	LOT QTY
SW100	1" MALE X 1" FEMALE SWIVEL	300	10
SW150	1 1/2" MALE X 1 1/2" FEMALE SWIVEL	300	1
SW220	2" FULL PORT MALE X 2" FULL PORT FEMALE SWIVEL	150	1



## 8 STATION MANIFOLD

PART NO	DESCRIPTION	MAX PSI	QTY
TM075/050	8 STATION MANIFOLD 3/4" INLET X 1/2" OUTLET. 1/4" GAUGE PORT	225	1

## PIPE FITTINGS

### FEATURES

- Glass reinforced polypropylene
- Heavy duty (Schedule 80)
- Lightweight with excellent strength
- NPT threads
- Excellent chemical resistance
- Parts must be ordered in lot quantities.

## PIPE SEALANT



### PIPE SEALANT

PART NO	DESCRIPTION	LOT QTY
RS21	RECTORSEAL® NO. 21™ (8 OZ W/ BRUSH IN CAP-24/CASE)	1
RSTB	RECTORSEAL® TRU-BLU™ (8 OZ W/ BRUSH IN CAP-24/CASE)	24

Recommended procedure for sealing pipe threads:

We DO NOT recommend using pipe tape. Pipe tape enlarges the outside diameter of the male thread and may cause the female thread to split. We recommend using a pipe thread sealant. Use on clean tapered threads. Apply a thick even coat on male threads using brush applicator. For pipe diameters smaller than 1 1/4" apply to male threads only. For 1 1/4" and larger sizes apply to both male and female threads. Avoid applying excessive amounts. Hand tighten joints and then torque another 1/2 to 3/4 turn until threads seal.

### FEATURES

- RectorSeal® No. 21™ is slow drying, soft set multi-purpose sealant designed for use where black is preferred. 8 oz can with brush in the cap. Conforms to TT-S-1732.
- RectorSeal® Tru-Blu™ is fast drying, flexible set designed for high vibration environments. Teflon™ has been added to enhance thread lubrication during assembly and break out. Conforms to TT-S-1732.

\*DuPont Registered Trademark

# LINE STRAINERS

## MINI T STRAINERS

### FEATURES

- Heavy duty glass reinforced polypropylene
- Clear bowl made of polycarbonate
- Black bowl made of polypropylene
- Polypropylene ribbed 316 stainless steel screens
- EPDM gaskets
- Convenient color coded screens for easy mesh size identification (Refer to chart on next page)



### MINI T STRAINERS W/CLEAR BOWLS

PART NO	DESCRIPTION	MAX PSI	QTY
LSTM050-30C	1/2" X 1/2" CLEAR BOWL STRAINER W/30 MESH SCREEN	100	1
LSTM050-50C	1/2" X 1/2" CLEAR BOWL STRAINER W/50 MESH SCREEN	100	1
LSTM050-80C	1/2" X 1/2" CLEAR BOWL STRAINER W/80 MESH SCREEN	100	1
LSTM075-30C	3/4" X 3/4" CLEAR BOWL STRAINER W/30 MESH SCREEN	100	1
LSTM075-50C	3/4" X 3/4" CLEAR BOWL STRAINER W/50 MESH SCREEN	100	1
LSTM075-80C	3/4" X 3/4" CLEAR BOWL STRAINER W/80 MESH SCREEN	100	1



### MINI T STRAINERS W/BLACK BOWLS

PART NO	DESCRIPTION	MAX PSI	QTY
LSTM050-30	1/2" X 1/2" BLACK BOWL STRAINER W/30 MESH SCREEN	200	1
LSTM050-50	1/2" X 1/2" BLACK BOWL STRAINER W/50 MESH SCREEN	200	1
LSTM050-80	1/2" X 1/2" BLACK BOWL STRAINER W/80 MESH SCREEN	200	1
LSTM075-30	3/4" X 3/4" BLACK BOWL STRAINER W/30 MESH SCREEN	200	1
LSTM075-50	3/4" X 3/4" BLACK BOWL STRAINER W/50 MESH SCREEN	200	1
LSTM075-80	3/4" X 3/4" BLACK BOWL STRAINER W/80 MESH SCREEN	200	1

## MINI T STRAINERS

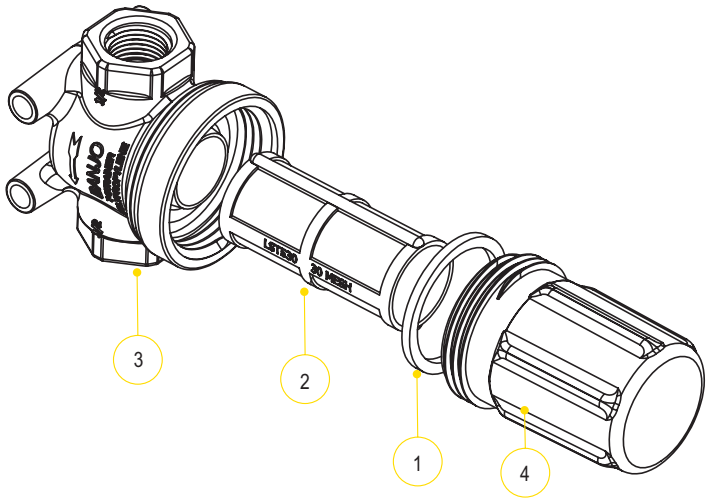

SCREENS	
MESH SIZE	RIB COLOR
30 MESH	FLAME RED
50 MESH	GENTIAN BLUE
80 MESH	ZINC YELLOW
100 MESH	TRAFFIC GREEN

REPLACEMENT PARTS			
ITEM	PART NO	DESCRIPTION	QTY
1	LSTM050G	EPDM GASKET	1
2	LST530	30 MESH SCREEN	1
2	LST550	50 MESH SCREEN	1
2	LST580	80 MESH SCREEN	1
2	LST5100	100 MESH SCREEN	1
3	LSTM050H	1/2" STRAINER HEAD	1
3	LSTM075H	3/4" STRAINER HEAD	1
4	LSTM050BC	CLEAR BOWL	1
4	LSTM050B	BLACK BOWL	1

STANDARD MESHES & DATA				
	30 MESH	50 MESH	80 MESH	100 MESH
MICRONS	595	297	177	149
WIRE DIAMETER	.012	.009	.0055	.0045
OPENING	.021	.011	.007	.005
% OPEN AREA	40.8	30.3	31.4	30.3

# LINE STRAINERS

## ¾"-1½" T STRAINERS

### FEATURES

- Heavy duty glass reinforced polypropylene
- Clean out plug
- Polypropylene ribbed 316 stainless steel screens
- EPDM gaskets standard, FKM available
- Convenient color coded screens for easy mesh size identification (Refer to chart on next page)



### ¾"-1" T STRAINERS

PART NO	DESCRIPTION	MAX PSI	QTY
LST075-16	¾" X ¾" FP T STRAINER W/16 MESH SS SCREEN	300	1
LST075-30	¾" X ¾" FP T STRAINER W/30 MESH SS SCREEN	300	1
LST075-50	¾" X ¾" FP T STRAINER W/50 MESH SS SCREEN	300	1
LST075-80	¾" X ¾" FP T STRAINER W/80 MESH SS SCREEN	300	1
LST075-100	¾" X ¾" FP T STRAINER W/100 MESH SS SCREEN	300	1
LST100-16	1" X 1" T STRAINER W/16 MESH SS SCREEN	300	1
LST100-30	1" X 1" T STRAINER W/30 MESH SS SCREEN	300	1
LST100-50	1" X 1" T STRAINER W/50 MESH SS SCREEN	300	1
LST100-80	1" X 1" T STRAINER W/80 MESH SS SCREEN	300	1
LST100-100	1" X 1" T STRAINER W/100 MESH SS SCREEN	300	1

### 1¼"-1½" T STRAINERS

PART NO	DESCRIPTION	MAX PSI	QTY
LST125-16	1¼" X 1¼" FP T STRAINER W/16 MESH SS SCREEN	300	1
LST125-30	1¼" X 1¼" FP T STRAINER W/30 MESH SS SCREEN	300	1
LST125-50	1¼" X 1¼" FP T STRAINER W/50 MESH SS SCREEN	300	1
LST125-80	1¼" X 1¼" FP T STRAINER W/80 MESH SS SCREEN	300	1
LST150-30	1½" X 1½" T STRAINER W/30 MESH SS SCREEN	300	1
LST150-50	1½" X 1½" T STRAINER W/50 MESH SS SCREEN	300	1
LST150-80	1½" X 1½" T STRAINER W/80 MESH SS SCREEN	300	1
LST150-100	1½" X 1½" T STRAINER W/100 MESH SS SCREEN	300	1

## 3/4"-1 1/2" T STRAINERS

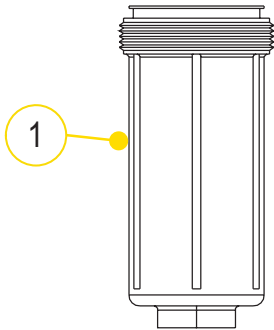
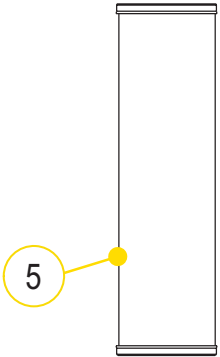
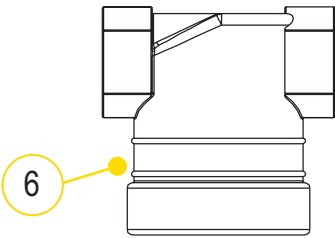

REPLACEMENT PARTS			
ITEM	PART NO	DESCRIPTION	QTY
1	LST100-B	3/4" & 1" BOWL (CONTAINS #1, #3, #4)	1
2	LST100-G	3/4" & 1" EPDM GASKET	1
2	LST100-GV	3/4" & 1" FKM GASKET	1
3	12777	1/2" PLUG	1
4	UV15163	EPDM O-RING FOR CLEAN OUT PLUG	1
5	LST116	16 MESH SCREEN	1
5	LST130	30 MESH SCREEN	1
5	LST150	50 MESH SCREEN	1
5	LST180	80 MESH SCREEN	1
5	LST1100	100 MESH SCREEN	1
6	LST075-H	3/4" STRAINER HEAD	1
6	LST100-H	1" STRAINER HEAD	1
N/S	LST075-HB	3/4" STRAINER HEAD, BOWL & GASKET	1
N/S	LST100-HB	1" STRAINER HEAD, BOWL & GASKET	1

REPLACEMENT PARTS			
ITEM	PART NO	DESCRIPTION	QTY
1	LST150-B	1 1/4" & 1 1/2" BOWL (CONTAINS #1, #3, #4)	1
2	LST150-G	1 1/4" & 1 1/2" EPDM GASKET	1
2	LST150-GV	1 1/4" & 1 1/2" FKM GASKET	1
3	LSQ200-PL	1" CLEAN OUT PLUG	1
4	LSQ200-R	EPDM O-RING FOR CLEAN OUT PLUG	1
5	LST1516	16 MESH SCREEN	1
5	LST1530	30 MESH SCREEN	1
5	LST1550	50 MESH SCREEN	1
5	LST1580	80 MESH SCREEN	1
5	LST15100	100 MESH SCREEN	1
6	N/A	1 1/4" STRAINER HEAD	1
N/S	LST125-HB	1 1/4" STRAINER HEAD, BOWL & GASKET	1
N/S	LST150-HB	1 1/2" STRAINER HEAD, BOWL & GASKET	1

STANDARD MESHES & DATA					
	16 MESH	30 MESH	50 MESH	80 MESH	100 MESH
MICRONS	1190	595	297	177	149
WIRE DIAMETER	.018	.012	.009	.0055	.0045
OPENING	.044	.021	.011	.007	.005
% OPEN AREA	50.7	40.8	30.3	31.4	30.3

SCREENS	
MESH SIZE	RIB COLOR
16 MESH	BROWN RED
30 MESH	FLAME RED
50 MESH	GENTIAN BLUE
80 MESH	ZINC YELLOW
100 MESH	TRAFFIC GREEN

# LINE STRAINERS

## 2" T STRAINERS POLY/STAINLESS COMBO

### FEATURES

- Heavy duty glass reinforced polypropylene bowl
- 316 stainless steel head
- Clean out plug
- 316 stainless steel screens
- FKM gaskets



### 2" T STRAINERS POLY/SS COMBO

PART NO	DESCRIPTION	MAX PSI	QTY
LST200-10SS	2" X 2" T STRAINER (SS HEAD & POLY BODY) W/10 MESH SCREEN	300	1
LST200-50SS	2" X 2" T STRAINER (SS HEAD & POLY BODY) W/50 MESH SCREEN	300	1

## LSQ STRAINERS

### FEATURES

- Precision molded in glass reinforced polypropylene
- Cam lever configuration for easy access for cleaning and servicing
- 3/4" plug in cam lever cap for attaching ball valve for draining or back flushing
- Poly ribbed 316 stainless steel screen
- EPDM lathe cut gasket
- For faster shipping, order in box quantities
- Convenient color coded screens for easy mesh size identification (Refer to chart on next page)



### 1½" LSQ STRAINERS

PART NO	DESCRIPTION	MAX PSI	LOT QTY
LSQ150-B/C	1½" X 1½" LSQ STRAINER BODY/CAP	N/A	1

### 2" LSQ STRAINERS

PART NO	DESCRIPTION	MAX PSI	LOT QTY
LSQ200-06	2" X 2" LSQ STRAINER W/6 MESH SCREEN	100	6/BOX
LSQ200-20	2" X 2" LSQ STRAINER W/20 MESH SCREEN	100	6/BOX
LSQ200-30	2" X 2" LSQ STRAINER W/30 MESH SCREEN	100	6/BOX
LSQ200-50	2" X 2" LSQ STRAINER W/50 MESH SCREEN	100	6/BOX
LSQ200-80	2" X 2" LSQ STRAINER W/80 MESH SCREEN	100	6/BOX

# LINE STRAINERS

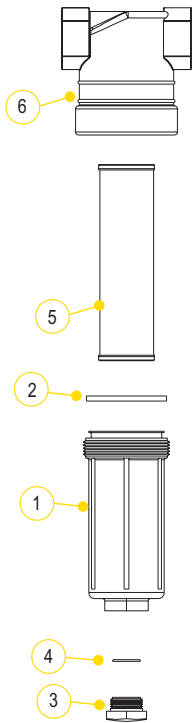

REPLACEMENT PARTS			
ITEM	PART NO	DESCRIPTION	QTY
1	LST200-B	2" POLY BOWL (CONTAINS #1, #3, #4)	1
2	LST200-GV	2" FKM GASKET	1
3	LSQ200-PL	1" CLEAN OUT PLUG	1
4	LSQ200-RV	FKM O-RING FOR CLEAN OUT PLUG	1
5	LST204SS	4 MESH SS SCREEN	1
5	LST206SS	6 MESH SS SCREEN	1
5	LST208SS	8 MESH SS SCREEN	1
5	LST210SS	10 MESH SS SCREEN	1
5	LST216SS	16 MESH SS SCREEN	1
5	LST220SS	20 MESH SS SCREEN	1
5	LST230SS	30 MESH SS SCREEN	1
5	LST250SS	50 MESH SS SCREEN	1
5	LST280SS	80 MESH SS SCREEN	1
6	LST200-HSS	2" SS HEAD	1

## 2" T STRAINERS POLY/STAINLESS COMBO

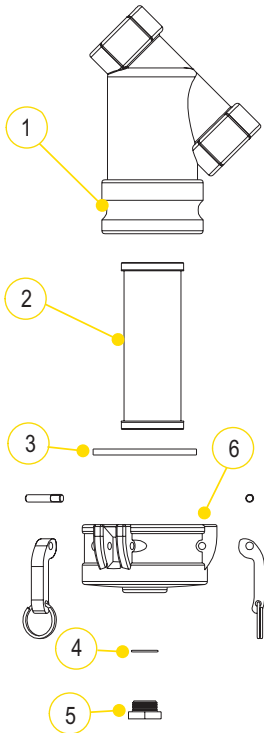

REPLACEMENT PARTS			
ITEM	PART NO	DESCRIPTION	QTY
1	N/A	2" LSQ BODY	1
2	LS206	6 MESH SCREEN	1
2	LS212	12 MESH SCREEN	1
2	LS220	20 MESH SCREEN	1
2	LS230	30 MESH SCREEN	1
2	LS250	50 MESH SCREEN	1
2	LS280	80 MESH SCREEN	1
2	LS2120	120 MESH SCREEN	1
3	LSQ150-B/C	1½" X 1½" LSQ STRAINER BODY/CAP	1
3	LSQ200-G	2" EPDM GASKET	1
3	LSQ200-GV	2" FKM GASKET	1
4	LSQ200R1	O-RING	1
5	N/A	¼" CLEAN OUT PLUG	1
6	LSQ200-C	2" CAP (CONTAINS #3-6)	1
N/S	LSQ200-B/C	2" BODY/CAP (CONTAINS #1, 3-6)	1

## LSQ STRAINERS

### SCREENS

MESH SIZE	RIB COLOR
6 MESH	WHITE
12 MESH	BLACK
20 MESH	BEIGE
30 MESH	FLAME RED
50 MESH	GENTIAN BLUE
80 MESH	ZINC YELLOW
120 MESH	BLACK

### STANDARD MESHES & DATA

	6 MESH	8 MESH	10 MESH	12 MESH	16 MESH	20 MESH	30 MESH	50 MESH	80 MESH	100 MESH	120 MESH
MICRONS	3360	2380	2000	1680	1190	841	595	297	177	149	116
WIRE DIAMETER	.035	.028	.025	.023	.018	.016	.012	.009	.0055	.0045	.0037
OPENING	.132	.097	.075	.060	.044	.034	.021	.011	.007	.005	.0046
% OPEN AREA	62.7	60.2	56.3	51.8	50.7	46.2	40.8	30.3	31.4	30.3	30.5

# LINE STRAINERS

## ½"-1¼" Y STRAINERS

### FEATURES

- Heavy duty glass reinforced polypropylene
- Corrosion resistant
- Easy grip end cap
- Heavy duty end cap threads
- Clean out plug
- Polypropylene ribbed 316 stainless steel screens
- EPDM gaskets
- Convenient color coded screens for easy mesh size identification (Refer to chart on next page)



### ½"-¾" Y STRAINERS

PART NO	DESCRIPTION	MAX PSI	QTY
LS050-20	½" X ½" FP Y STRAINER W/20 MESH SS SCREEN	225	1
LS050-40	½" X ½" FP Y STRAINER W/40 MESH SS SCREEN	225	1
LS050-80	½" X ½" FP Y STRAINER W/80 MESH SS SCREEN	225	1
LS075-20	¾" X ¾" Y STRAINER W/20 MESH SS SCREEN	225	1
LS075-40	¾" X ¾" Y STRAINER W/40 MESH SS SCREEN	225	1
LS075-80	¾" X ¾" Y STRAINER W/80 MESH SS SCREEN	225	1



### 1"-1¼" Y STRAINERS

PART NO	DESCRIPTION	MAX PSI	QTY
LS100-20	1" X 1" Y STRAINER W/20 MESH SS SCREEN	200	1
LS100-40	1" X 1" Y STRAINER W/40 MESH SS SCREEN	200	1
LS100-80	1" X 1" Y STRAINER W/80 MESH SS SCREEN	200	1
LS125-20	1¼" X 1¼" Y STRAINER W/20 MESH SS SCREEN	200	1
LS125-40	1¼" X 1¼" Y STRAINER W/40 MESH SS SCREEN	200	1
LS125-80	1¼" X 1¼" Y STRAINER W/80 MESH SS SCREEN	200	1

## 1/2" - 1/4" Y STRAINERS

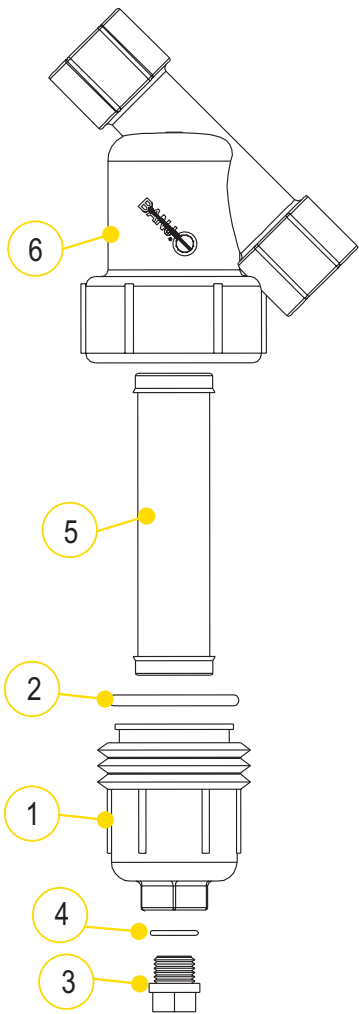

### REPLACEMENT PARTS

ITEM	PART NO	DESCRIPTION	QTY
1	N/A	1/2"-3/4" END CAP (CONTAINS #1, #3, #4)	1
2	LS075-G	1/2"-3/4" O-RING	1
3	12723	1/4" DRAIN PLUG (FITS 1/2"-3/4")	1
4	12724	1/2"-3/4" EPDM O-RING FOR DRAIN PLUG	1
5	LS720	1/2"-3/4" 20 MESH SCREEN	1
5	LS740	1/2"-3/4" 40 MESH SCREEN	1
5	LS780	1/2"-3/4" 80 MESH SCREEN	1
6	N/A	3/4" Y BODY	1
N/S	LS050B/C1	1/2" Y BODY, CAP & GASKET	1
N/S	LS075B/C1	3/4" Y BODY, CAP & GASKET	1

### REPLACEMENT PARTS

ITEM	PART NO	DESCRIPTION	QTY
1	LS100-C1	1"-1 1/4" END CAP (CONTAINS #1, #3, #4)	1
2	LS100-G	1"-1 1/4" O-RING	1
2	LS100-GV	1"-1 1/4" FKM GASKET	1
3	12777	1/2" PLUG (FITS 1"-1 1/4")	1
4	UV15163	EPDM O-RING FOR DRAIN PLUG	1
4	UV15163V	FKM O-RING FOR DRAIN PLUG	1
5	LS120	1"-1 1/4" 20 MESH SCREEN	1
5	LS140	1"-1 1/4" 40 MESH SCREEN	1
5	LS180	1"-1 1/4" 80 MESH SCREEN	1
6	N/A	1" Y BODY	1
6	N/A	1 1/4" Y BODY	1
N/S	LS100B/C1	1" Y BODY, CAP & GASKET	1
N/S	LS125B/C1	1 1/4" Y BODY, CAP & GASKET	1

### SCREENS

MESH SIZE	RIB COLOR
6 MESH	WHITE
12 MESH	BLACK
20 MESH	BEIGE
30 MESH	FLAME RED
40 MESH	BROWN
50 MESH	GENTIAN BLUE
60 MESH	GENTIAN BLUE
80 MESH	ZINC YELLOW
100 MESH	TRAFFIC GREEN
120 MESH	BLACK

### STANDARD MESHES & DATA

	6 MESH	8 MESH	10 MESH	12 MESH	16 MESH	20 MESH	30 MESH	50 MESH	80 MESH	100 MESH	120 MESH
MICRONS	3360	2380	2000	1680	1190	841	595	297	177	149	116
WIRE DIAMETER	.035	.028	.025	.023	.018	.016	.012	.009	.0055	.0045	.0037
OPENING	.132	.097	.075	.060	.044	.034	.021	.011	.007	.005	.0046
% OPEN AREA	62.7	60.2	56.3	51.8	50.7	46.2	40.8	30.3	31.4	30.3	30.5

# LINE STRAINERS

## 1½"-2" Y STRAINERS

### FEATURES

- Heavy duty glass reinforced polypropylene
- Corrosion resistant
- Easy grip end cap
- Heavy duty end cap threads
- Clean out plug
- Polypropylene ribbed 316 stainless steel screens
- EPDM gaskets
- Convenient color coded screens for easy mesh size identification (Refer to chart on next page)



### 1½" Y STRAINERS

PART NO	DESCRIPTION	MAX PSI	QTY
LS150-06	1½" X 1½" Y STRAINER W/6 MESH SS SCREEN	150	1
LS150-12	1½" X 1½" Y STRAINER W/12 MESH SS SCREEN	150	1
LS150-20	1½" X 1½" Y STRAINER W/20 MESH SS SCREEN	150	1
LS150-30	1½" X 1½" Y STRAINER W/30 MESH SS SCREEN	150	1
LS150-50	1½" X 1½" Y STRAINER W/50 MESH SS SCREEN	150	1
LS150-80	1½" X 1½" Y STRAINER W/80 MESH SS SCREEN	150	1
LS150-120	1½" X 1½" Y STRAINER W/120 MESH SS SCREEN	150	1



### 2" Y STRAINERS

PART NO	DESCRIPTION	MAX PSI	LOT QTY
LS200-06	2" X 2" Y STRAINER W/6 MESH POLY RIBBED SS SCREEN	150	1
LS200-12	2" X 2" Y STRAINER W/12 MESH POLY RIBBED SS SCREEN	150	1
LS200-20	2" X 2" Y STRAINER W/20 MESH POLY RIBBED SS SCREEN	150	1
LS200-30	2" X 2" Y STRAINER W/30 MESH POLY RIBBED SS SCREEN	150	1
LS200-50	2" X 2" Y STRAINER W/50 MESH POLY RIBBED SS SCREEN	150	5
LS200-80	2" X 2" Y STRAINER W/80 MESH POLY RIBBED SS SCREEN	150	1
LS200-100	2" X 2" Y STRAINER W/100 MESH POLY RIBBED SS SCREEN	150	1
LS200-120	2" X 2" Y STRAINER W/120 MESH POLY RIBBED SS SCREEN	150	1

## 1½"-2" Y STRAINERS

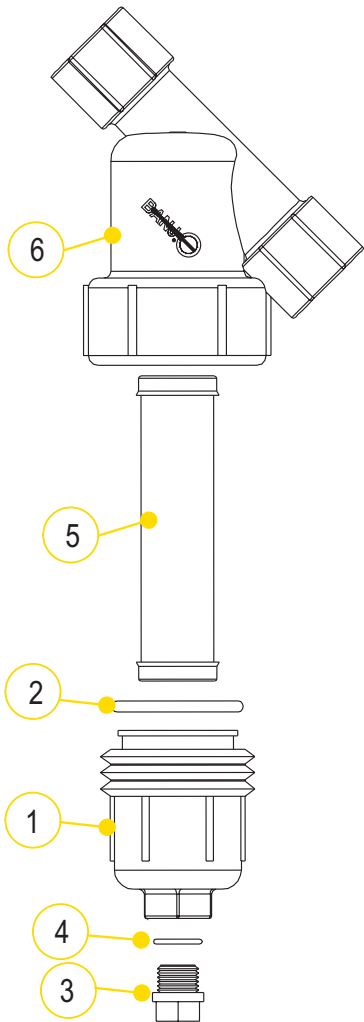

### REPLACEMENT PARTS

ITEM	PART NO	DESCRIPTION	QTY
1	LS150-C	1½" - 2" END CAP (CONTAINS #1, #3, #4)	1
2	LS150-G	1½"-2" O-RING	1
2	LS150-GV	1½"-2" FKM GASKET	1
3	LSQ200-PL	1" DRAIN PLUG (FITS 1½" - 2")	1
4	LSQ200-RV	1½"-2" FKM O-RING FOR DRAIN PLUG	1
5	LS206	1½"-2" 6 MESH SCREEN	1
5	LS212	1½"-2" 12 MESH SCREEN	1
5	LS220	1½"-2" 20 MESH SCREEN	1
5	LS230	1½"-2" 30 MESH SCREEN	1
5	LS250	1½"-2" 50 MESH SCREEN	1
5	LS280	1½"-2" 80 MESH SCREEN	1
5	LS2100	1½"-2" 100 MESH SCREEN	1
5	LS2120	1½"-2" 120 MESH SCREEN	1
5	LS250P	1½"-2" 50 MESH ALL POLY SCREEN	1
6	N/A	1½" Y BODY	1
6	N/A	2" Y BODY	1
N/S	LS150B/C	1½" Y BODY, CAP & GASKET	1
N/S	LS200B/C	2" Y BODY, CAP & GASKET	1

### SCREENS

MESH SIZE	RIB COLOR
6 MESH	WHITE
12 MESH	BLACK
20 MESH	BEIGE
30 MESH	FLAME RED
40 MESH	BROWN
50 MESH	GENTIAN BLUE
80 MESH	ZINC YELLOW
100 MESH	TRAFFIC GREEN
120 MESH	BLACK

### STANDARD MESHES & DATA

	6 MESH	8 MESH	12 MESH	20 MESH	30 MESH	50 MESH	80 MESH	100 MESH	120 MESH
MICRONS	3360	2380	1680	841	595	297	177	149	116
WIRE DIAMETER	.035	.028	.023	.016	.012	.009	.0055	.0045	.0037
OPENING	.132	.097	.060	.034	.021	.011	.007	.005	.0046
% OPEN AREA	62.7	60.2	51.8	46.2	40.8	30.3	31.4	30.3	30.5

# LINE STRAINERS

## 3" Y STRAINERS

### FEATURES

- Heavy duty glass reinforced polypropylene
- Corrosion resistant
- High volume
- Heavy duty end cap threads
- ½" clean out plug
- 304 stainless steel screens
- EPDM gaskets
- Warning: to be used on suction side or non-pressure side in all applications



### 3" Y STRAINERS

PART NO	DESCRIPTION	MAX PSI	LOT QTY
LSM300-04	3" X 3" Y STRAINER W/4 MESH SCREEN	75	1
LSM300-08	3" X 3" Y STRAINER W/8 MESH SCREEN	75	1
LSM300-12	3" X 3" Y STRAINER W/12 MESH SCREEN	75	1
LSM300-20	3" X 3" Y STRAINER W/20 MESH SCREEN	75	1
LSM300-50	3" X 3" Y STRAINER W/50 MESH SCREEN	75	1

## 3" Y STAINLESS STEEL STRAINERS

### FEATURES

- Heavy duty stainless steel
- Corrosion resistant
- High volume
- Heavy duty end cap threads
- ½" clean out plug
- 304 stainless steel screens
- EPDM gaskets standard, FKM available
- Maximum operating pressure 225 psi
- Warning: to be used on suction side or non-pressure side in all applications



### 3" Y STRAINERS

PART NO	DESCRIPTION	QTY
LSS300-BC	3" SS BODY, CAP & GASKETS	1
LSS300-C	3" SS CAP	1
LSS300-S	EPDM SCREEN SEAL	1
LSS300-SV	FKM SCREEN SEAL	1
LSS300-G	EPDM CAP GASKET	1
LSS300-GV	FKM CAP GASKET	1

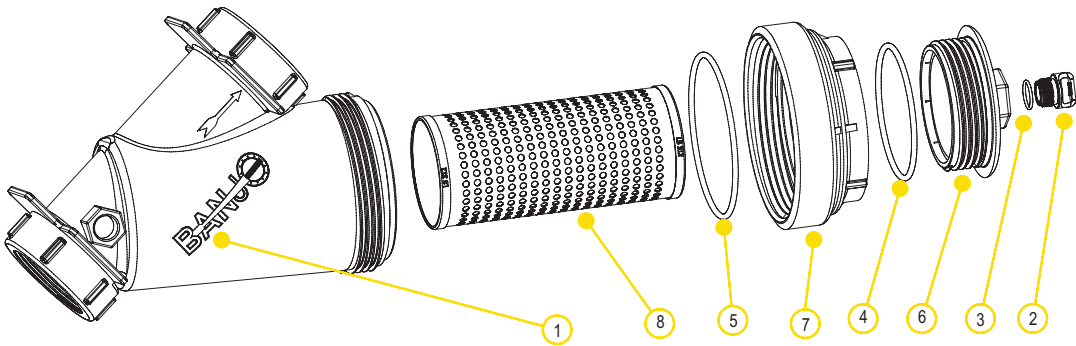

## 3" Y STRAINERS

- 304 stainless steel screens

### REPLACEMENT PARTS

ITEM	PART NO	DESCRIPTION	QTY
1	MLS300B1	3" BODY	1
2	13777	3/4" PLUG	1
3	13778	O-RING	1
4	MLS300ECG	EPDM END CAP GASKET	1
4	MLS300ECGV	FKM CAP GASKET	1
5	MLS300G	EPDM CAP GASKET	1
6	LS300EC	END CAP ONLY (PLUG SOLD SEPARATELY)	1
7	MLS300CAP	3" CAP	1
8	LS304	4 MESH SCREEN	1
8	LS308	8 MESH SCREEN	1
8	LS312	12 MESH SCREEN	1
8	LS320	20 MESH SCREEN	1
8	LS350	50 MESH SCREEN	1

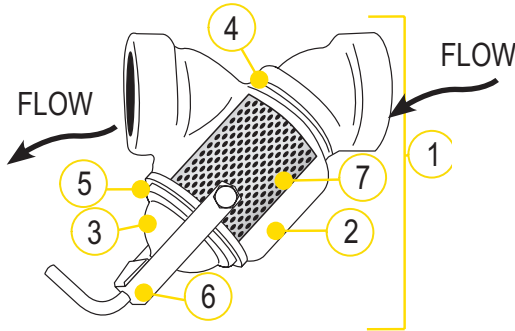

## 3" Y STAINLESS STEEL STRAINERS

- 304 stainless steel screens

### REPLACEMENT PARTS

ITEM	PART NO	DESCRIPTION	QTY
1	LSS300-BC	3" SS BODY, CAP & GASKETS	1
2	N/A	3" SS BODY	1
3	LSS300-C	3" SS CAP	1
4	LSS300-S	EPDM SCREEN SEAL	1
4	LSS300-SV	FKM SCREEN SEAL	1
5	LSS300-G	EPDM CAP GASKET	1
5	LSS300-GV	FKM CAP GASKET	1
6	LSS300-H	HANDLE/CLAMP ASSEMBLY	1
7	LSS306	6 MESH SS SCREEN	1
7	LSS308	8 MESH SS SCREEN	1
7	LSS312	12 MESH SS SCREEN	1
7	LSS320	20 MESH SS SCREEN	1
7	LSS330	30 MESH SS SCREEN	1
7	LSS350	50 MESH SS SCREEN	1
7	LSS380	80 MESH SS SCREEN	1

# CENTRIFUGAL PUMPS

**PUMP ACCESSORIES**  
**PAGES 95**

SUCTION BASKET STRAINERS  
BASE PLATES

**2" POLY PUMPS**  
**PAGES 96 - 109**

GAS ENGINE PUMPS  
PUMP ONLY/ BEARING PEDESTAL  
WET SEAL WITH GAS ENGINE  
ELECTRIC MOTOR DRIVEN  
HYDRAULIC MOTOR DRIVEN  
MANIFOLD

**3" POLY PUMPS**  
**PAGES 110- 119**

GAS ENGINE PUMPS  
PUMP ONLY/ BEARING PEDESTAL  
MANIFOLD  
HYDRAULIC MOTOR DRIVEN  
WET SEAL WITH GAS ENGINE

**1½" & 2" CAST IRON PUMPS**  
**PAGES 120 - 127**

GAS ENGINE PUMPS  
PUMP ONLY/ BEARING PEDESTAL  
WET SEALS  
ELECTRIC MOTOR DRIVEN  
HYDRAULIC MOTOR DRIVEN

**2" CAST IRON 222**  
**SERIES PUMPS**  
**PAGES 128- 131**

GAS ENGINE PUMPS  
PUMP ONLY/ BEARING PEDESTAL  
HYDRAULIC MOTOR DRIVEN  
ELECTRIC MOTOR DRIVEN  
MANIFOLD WET SEAL

**3" CAST IRON PUMPS**  
**PAGES 132 - 137**

GAS ENGINE PUMPS  
PUMP ONLY/ BEARING PEDESTAL  
WET SEALS  
HYDRAULIC MOTOR DRIVEN

**3" CAST IRON 333**  
**SERIES PUMPS**  
**PAGES 138 - 139**

GAS ENGINE PUMPS  
PUMP ONLY/ BEARING PEDESTAL  
ELECTRIC MOTOR DRIVEN

**3" CAST IRON MANIFOLD WET**  
**SEAL M332 SERIES PUMPS**  
**PAGES 140 - 143**

GAS ENGINE PUMPS  
PUMP ONLY/ BEARING PEDESTAL  
ELECTRIC MOTOR DRIVEN  
HYDRAULIC MOTOR DRIVEN

**4" CAST IRON 444**  
**SERIES PUMPS**  
**PAGES 144 - 145**

GAS ENGINE PUMPS  
PUMP ONLY

**2" & 3" STAINLESS STEEL**  
**PUMPS**  
**PAGES 146- 153**

GAS ENGINE PUMPS  
PUMP ONLY/ BEARING PEDESTAL  
ELECTRIC MOTOR DRIVEN  
HYDRAULIC MOTOR DRIVEN

## SUCTION BASKET STRAINERS



### SUCTION BASKET STRAINERS

PART NO	DESCRIPTION	QTY
200SBS	2" FEMALE THREAD POLY BASKET	1
300SBS	3" FEMALE THREAD POLY BASKET	1

### FEATURES

- Made of polyethylene
- Prevents plugging and damage to pump while suctioning from streams or ponds.

## BASE PLATE ASSEMBLY



### BASE PLATE ASSEMBLY

PART NO	DESCRIPTION	QTY
18700	BASE PLATE ASSEMBLY INCLUDES PLATE, COUPLING GUARD, BOLT BAG AND SHIMS	1

### FEATURES

- Universal fit for 1½", 2" and 3" polypropylene or cast iron pumps

# CENTRIFUGAL PUMPS

## 2" POLY PUMPS

### FEATURES

- Precision molded construction
- Lightweight
- Corrosion resistant
- Superior design
- Low maintenance
- EPDM standard, FKM available
- Engine warranty service available at authorized Briggs & Stratton® and Honda® dealers



WARNING! DO NOT RUN PUMP DRY, RESTRICT OR REDUCE PORT SIZES OR DEAD HEAD PUMP



WARNING! DO NOT USE WITH FLAMMABLE LIQUIDS



### 2" POLY PUMPS W/GAS ENGINES

PART NO	DESCRIPTION	HP	QTY	SKID QTY
200PH-5E	2" POLY PUMP W/5.5 HP HONDA® ENGINE W/ ELECTRIC START	5.5	1	12
200PH6	2" POLY PUMP W/6.5 HP HONDA® ENGINE	6.5	1	12
200PH6V	2" POLY PUMP W/6.5 HP HONDA® ENGINE W/FKM & 316 SS SEAL	5.5	1	12
200P6PRO	2" POLY PUMP W/6.5 HP BRIGGS & STRATTON® ENGINE PRO SERIES	6.5	1	12
200P6PROE	2" POLY PUMP W/6.5 HP BRIGGS & STRATTON® ENGINE PRO SERIES W/ELECTRIC START	6.5	1	12
200P6PROV	2" POLY PUMP W/6.5 HP BRIGGS & STRATTON® ENGINE PRO SERIES W/FKM & 316 SS SEAL	6.5	1	12



### 2" POLY PUMP BEARING PEDESTALS

PART NO	DESCRIPTION	HP	QTY	SKID QTY
200PB	2" POLY BEARING PEDESTAL W/ 3/4" SHAFT & 3 VANE IMPELLER	N/A	1	18
205PB	2" POLY BEARING PEDESTAL W/ 3/4" SHAFT & 5 VANE IMPELLER	N/A	1	18
205PB-V	2" POLY BEARING PEDESTAL W/ 3/4" SHAFT & 5 VANE IMPELLER W/FKM & 316 SS SEAL	N/A	1	18



### 2" POLY PUMP ONLYS

PART NO	DESCRIPTION	HP	QTY	SKID QTY
200PO	2" POLY PUMP ONLY* W/ 3 & 5 VANE IMPELLER	N/A	1	27
200PO-V	2" POLY PUMP ONLY* W/ 3 & 5 VANE IMPELLER W/FKM & 316 SS SEAL	N/A	1	27

Note: Requires 3/4" shaft on motor

# CENTRIFUGAL PUMPS

## 2" POLY PUMPS

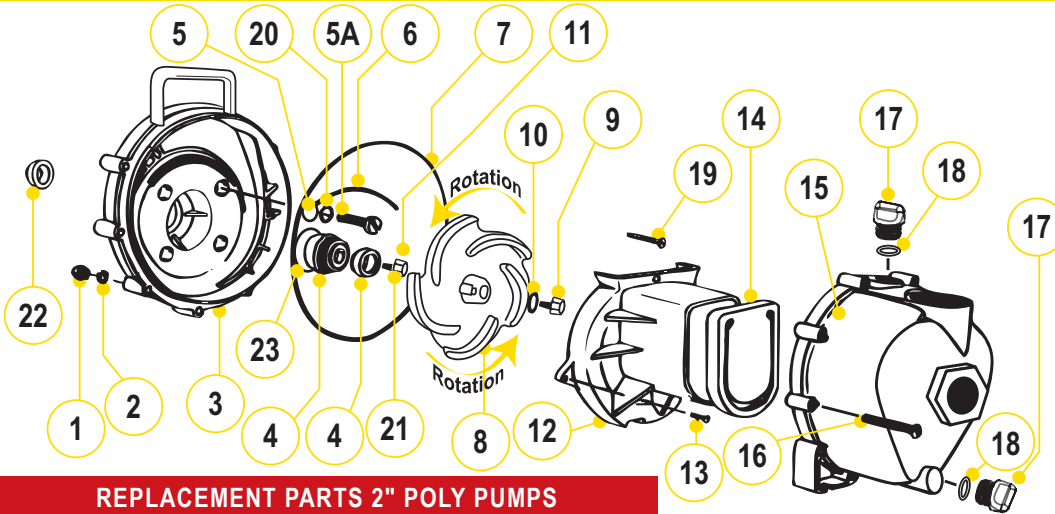

### REPLACEMENT PARTS 2" POLY PUMPS

ITEM	PART NO	DESCRIPTION	QTY
1	V07019	SS BODY NUTS	10
2	V07018	SS LOCK WASHERS	10
3	12703A	POLY PUMP REAR BRACKET	1
4	12713	SEAL ASSEMBLY	1
4	12713V	FKM SEAL ASSEMBLY	1
5	12717	O-RING FOR SCREW HEAD	4
5	12717V	FKM O-RING FOR SCREW HEAD	4
5A	12715A	SS BRACKET SCREWS	4
6	12754	O-RING SEGMENT	1
6	12754V	FKM O-RING SEGMENT	1
7	12719A	BODY O-RING	1
7	12719AV	FKM BODY O-RING	1
8	12772	5 VANE IMPELLER	1
8	12771A	3 VANE IMPELLER	1
9	12765A	SS IMPELLER BOLT	1
10	A204	O-RING	1
10	A204V	FKM O-RING	1
11	12775A	IMPELLER HEX NUT	1
12	12702A	POLY PUMP VOLUTE	1
13	12725	SS VOLUTE SCREWS	1
14	12705	POLY PUMP CHECK VALVE	1
14	12705V	FKM CHECK VALVE	1
15	12712A	BODY ASSEMBLY	1
16	12720	SS BODY SCREWS	10
17	12777	1/2" PLUG	2
18	UV15163	PRIME/DRAIN PLUG O-RING	2
18	UV15163V	FKM PRIME/DRAIN PLUG O-RING	2
19	12900	SS UPPER VOLUTE SCREW	1
20	12901	SS REAR BRACKET WASHER	4
21	12902A	IMPELLER KEY	1
22	12716	POLY PUMP SLINGER	1
23	12710	O-RING FOR SEAL ASSEMBLY	1
23	12710V	FKM O-RING FOR SEAL ASSEMBLY	1
N/S	12882A	BEARING PEDESTAL	1
N/S	12099	7/16"-14 X 1.25" HHCS	1
KIT	12000A	POLY PUMP EPDM REPAIR KIT (ITEMS 4-8, 10, 14, 18, 21-23 & 12099)	1
KIT	12000AV	POLY PUMP FKM REPAIR KIT (ITEMS 4-8, 10, 14, 18, 21-23 & 12099)	1
KIT	12999A	PUMP SEAL/O-RING KIT (ITEMS 5-7, 10, 18, 22, 23 & 12099)	1
KIT	12999AV	FKM PUMP SEAL/O-RING KIT (ITEMS 5-7, 10, 18, 22, 23 & 12099)	1

### KITS 2" POLY PUMPS

PART NO	REPAIR KIT NO	SEAL KIT NO
200PH-5E	12000A	12999A
200PH6	12000A	12999A
200PH6V	12000AV	12999AV
200P6PRO	12000A	12999A
200P6PROE	12000A	12999A
200P6PROV	12000AV	12999AV
200PB	12000A	12999A
205PB	12000A	12999A
205PB-V	12000AV	12999AV
200PO	12000A	12999A
200PO-V	12000AV	12999AV

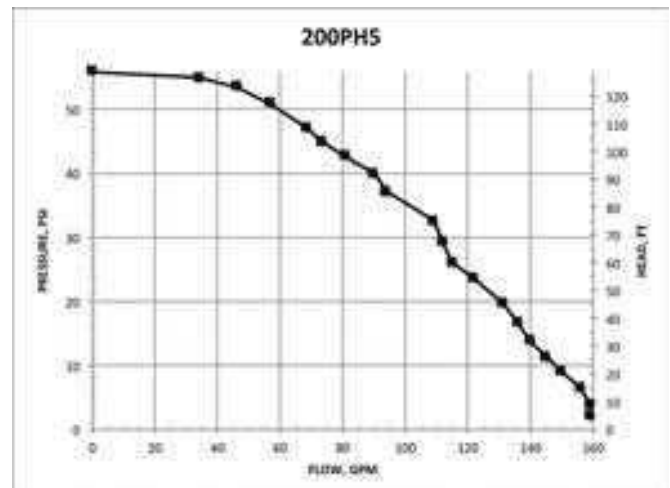
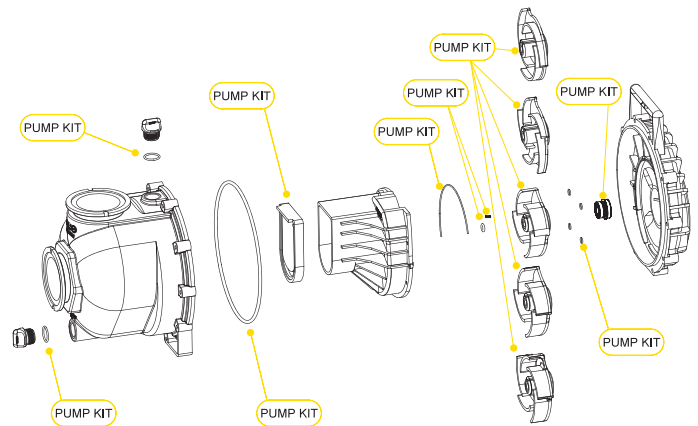

# CENTRIFUGAL PUMPS

## 2" POLY WET SEAL PUMPS

### FEATURES

- Run dry capability
- Double seal contained in ethylene glycol reservoir. Carbon ceramic seal faces with stainless steel cup and spring with EPDM rubber.
- Pump end separated from engine
- V-shaped for quicker priming
- Engine warranty service available at authorized Briggs & Stratton® and Honda® dealers



WARNING! DO NOT USE WITH  
FLAMMABLE LIQUIDS

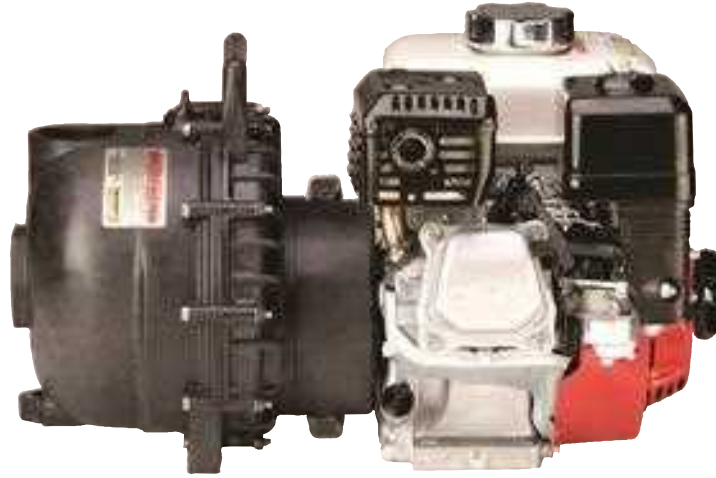

### 2" POLY WET SEAL PUMPS W/GAS ENGINES

PART NO	DESCRIPTION	HP	QTY	SKID QTY
200PH6W	2" POLY WET SEAL PUMP W/6.5 HP HONDA® ENGINE	5.5	1	12



### 2" POLY WET SEAL PUMP ONLY

PART NO	DESCRIPTION	HP	QTY	SKID QTY
205POW	2" POLY WET SEAL PUMP ONLY, 5 VANE IMPELLER WITH EPDM SEALS	N/A	1	27

# CENTRIFUGAL PUMPS

## 2" POLY WET SEAL PUMPS

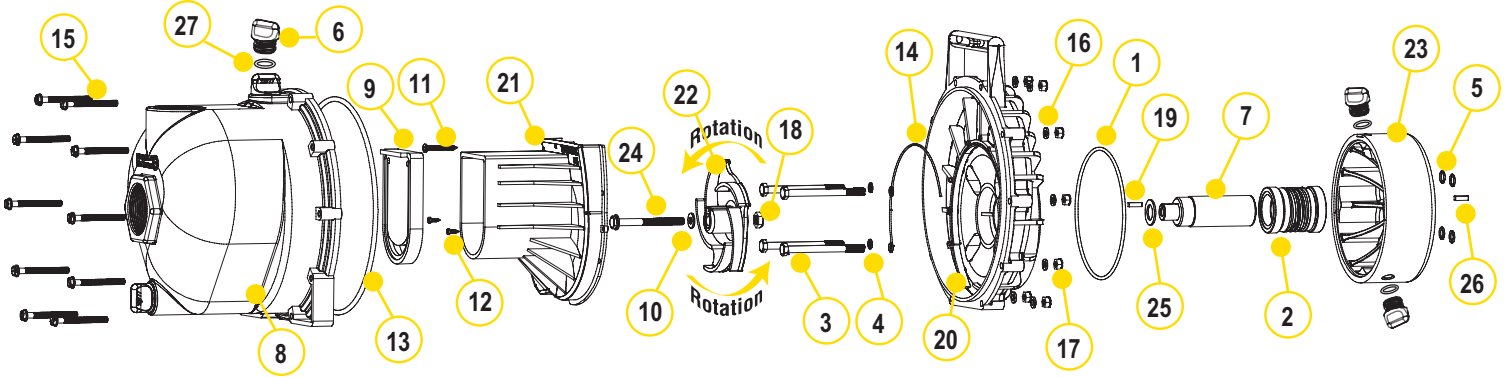

### REPLACEMENT PARTS 2" POLY PUMPS

ITEM	PART NO	DESCRIPTION	QTY
1	13719	O-RING	1
2	15035E	EPDM MECHANICAL SEAL ASSEMBLY	1
3	13034	5/16" -24 X 3 3/4" HHCS	4
4	12717	O-RING FOR BRACKET SCREW	4
5	12709	O-RING	4
6	12777	1/2" PLUG	4
7	12155	ADAPTER SHAFT	1
8	12712A	BODY ASSEMBLY	1
9	12705	CHECK VALVE	1
10	A204	IMPELLER BOLT GASKET	1
11	12900	#10 X 1 1/2" PPH SMS	1
12	12725	#6 X 1/2" PPH SMS	2
13	12719A	BODY O-RING	1
14	12754	O-RING SEGMENT	1
15	12720	1/4" - 20 X 2 1/2" SL IND HWHS	10
16	V07018	1/4" LOCK WASHER	10
17	V07019	1/4" - 20 HEX NUT	10
18	12775A	7/16" - 14 HEX NUT	1
19	12902A	3/16" SQ. X 5/8" KEY	2
20	12707W	WET SEAL REAR BRACKET	1
21	12702A	VOLUTE	1
22	12772	5 VANE IMPELLER	1
23	12202W	WET SEAL RESERVOIR	1
24	12766	5/16" - 24 X 3 1/4" HFS	1
25	CV10175	GASKET	1
26	12902A	1/4" SQ. 3/4" KEY STOCK	1
27	UV15163	O-RING FOR DRAIN PLUG	4
KIT	12000AW	CONTAINS # 1, 2, 4, 5, 9, 10, 13, 14, 22, 25, 27	1

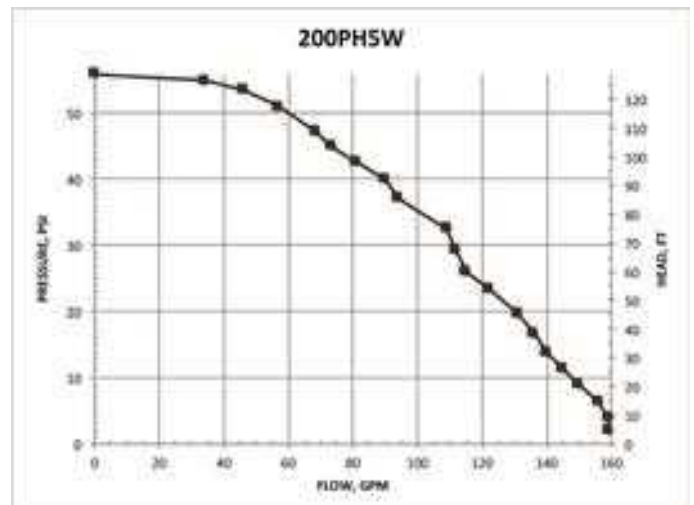

# CENTRIFUGAL PUMPS

## 2" POLY PUMPS WITH ELECTRIC MOTORS

### FEATURES

- Additional drive unit protection with added 1" spacer for ultimate protection
- The "Super Slinger" included for even more drive unit protection (not shown)



**WARNING! DO NOT RUN PUMP DRY, RESTRICT OR REDUCE PORT SIZES OR DEAD HEAD PUMP**



**WARNING! DO NOT USE WITH FLAMMABLE LIQUIDS**

### 2" POLY PUMPS W/ELECTRIC MOTORS

PART NO	DESCRIPTION	HP	QTY	SKID QTY
234PPE5	2" POLY PUMP W/5 HP THREE PHASE ELECTRIC MOTOR W/ EPDM ELASTOMERS	5	1	3
234PPE5V	2" POLY PUMP W/5 HP THREE PHASE ELECTRIC MOTOR W/FKM ELASTOMERS	5	1	3
234PPE51	2" POLY PUMP W/5 HP SINGLE PHASE ELECTRIC MOTOR W/ EPDM ELASTOMERS	5	1	3
234PPE51V	2" POLY PUMP W/5 HP SINGLE PHASE ELECTRIC MOTOR W/FKM ELASTOMERS	5	1	3

# CENTRIFUGAL PUMPS

2" POLY PUMPS WITH ELECTRIC MOTORS

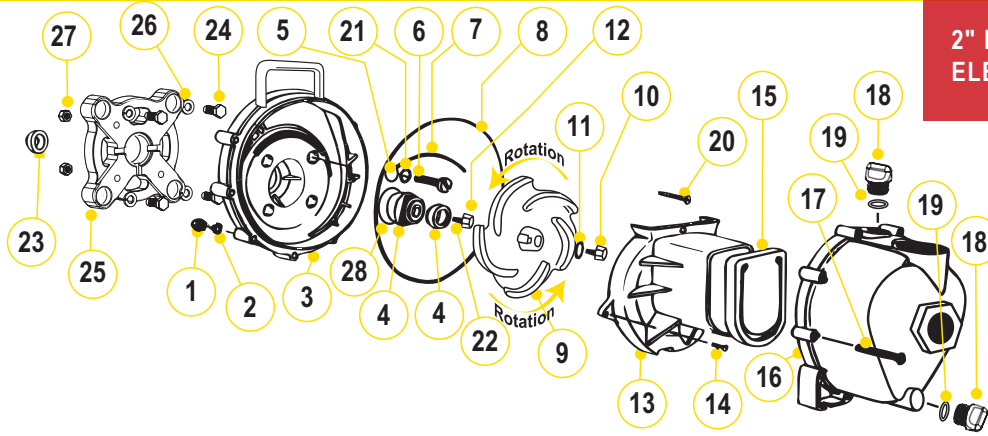

## REPLACEMENT PARTS 2" POLY PUMPS

ITEM	PART NO	DESCRIPTION	QTY
1	V07019	SS BODY NUTS	10
2	V07018	SS LOCK WASHERS	10
3	12703A	POLY PUMP REAR BRACKET	1
4	12713	SEAL ASSEMBLY EPDM	1
4	12713V	SEAL ASSEMBLY FKM	1
5	12717	SCREW HEADS O-RING EPDM	4
5	12717V	SCREW HEADS O-RING FKM	4
6	N/A	SS BRACKET SCREWS	4
7	12754	O-RING SEGMENT EPDM	1
7	12754V	O-RING SEGMENT FKM	1
8	12719A	BODY O-RING EPDM	1
8	12719AV	BODY O-RING FKM	1
9	12772	5 VANE IMPELLER	1
10	12765A	SS IMPELLER BOLT	1
11	A204	O-RING	1
11	A204V	FKM O-RING	1
12	12775A	IMPELLER HEX NUT	1
13	12702A	POLY PUMP VOLUTE	1
14	12725	SS VOLUTE SCREWS	2
15	12705	POLY PUMP CHECK VALVE EPDM	1
15	12705V	POLY PUMP CHECK VALVE FKM	1
16	12712A	BODY ASSEMBLY EPDM	1
16	N/A	BODY ASSEMBLY FKM	1
17	12720	SS BODY SCREWS	10
18	12777	1/2" PLUG	2
19	UV15163	PRIME/DRAIN PLUG O-RING	2
19	UV15163V	FKM PRIME/DRAIN PLUG O-RING	2
20	12900	SS UPPER VOLUTE SCREW	1
21	12901	SS REAR BRACKET WASHER	4
22	12902A	IMPELLER KEY	1
23	12716	PUMP SLINGER	1
24	17704	3/8"-16 X 1.25" HHCS	8
25	12046	56C FRAME ADAPTER	1
26	V20018	LOCK WASHER FOR 56C FRAME ADAPTER	8
27	V10119	NUT FOR 56C FRAME ADAPTER	4
28	12710	O-RING FOR SEAL ASSEMBLY	1
28	12710V	FKM O-RING FOR SEAL ASSEMBLY	1
NS	BEM5-182CZ	5 HP, 182CZ, 3 PH	1
NS	BEM51-182CZ	5 HP, 182CZ, 1 PH	1

## REPLACEMENT PARTS 2" POLY PUMPS

ITEM	PART NO	DESCRIPTION	QTY
N/S	17701	BASE PLATE	1
N/S	12099	7/16"-14 X 1.25" HHCS	1
N/S	12052	56C FRAME ADAPTER SHAFT FOR 200PEO	1
KIT	12756	56C FRAME ADAPTER KIT (ITEMS 6, 22, 24-27, 12052, 12053, 15751, 15752)	1
KIT	12000A	POLY PUMP EPDM REPAIR KIT (ITEMS 4, 5, 7, 8, 9, 11, 15, 19, 22-23 & 12099)	1
KIT	12000AV	POLY PUMP FKM REPAIR KIT (ITEMS 4, 5, 7, 8, 9, 11, 15, 19, 22-23 & 12099)	1
KIT	12999A	PUMP SEAL/O-RING KIT (ITEMS 4, 5, 7, 8, 11, 19, 23)	1
KIT	12999AV	FKM PUMP SEAL/O-RING KIT (ITEMS 4, 5, 7, 8, 11, 19, 23)	1

## KITS 2" POLY PUMPS

PART NO	REPAIR KIT NO	SEAL KIT NO	FRAME ADAPTER KIT
234PPE5	12000A	12999A	12756
234PPE5V	12000AV	12999AV	12756
234PPE51	12000A	12999A	12756
234PPE51V	12000AV	12999AV	12756

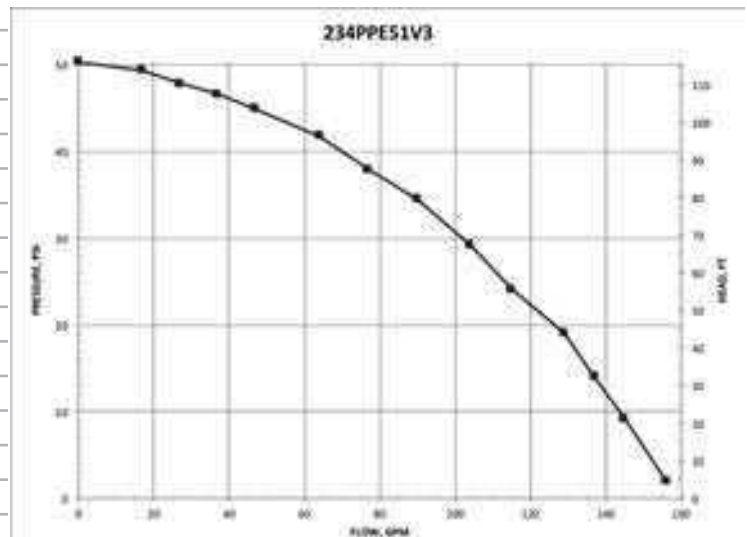

# CENTRIFUGAL PUMPS

## 2" POLY PUMPS WITH HYDRAULIC MOTORS

### FEATURES

- Precision molded construction
- Lightweight
- Corrosion resistant
- Low maintenance
- Hydraulic fluid capacity is minimum 6 gallons and maximum 10 gallons
- Open or closed system
- 3600 R.P.M.
- Recommendation to use the motor spool control valve or a suitable equivalent. The lack of such a valve in this circuit may cause failure to the hydraulic motor and will void warranty.



### 2" POLY PUMPS W/HYDRAULIC MOTORS

PART NO	DESCRIPTION	HP	QTY	SKID QTY
200PHA	2" POLY PUMP WITHOUT HYDRAULIC MOTOR	N/A	1	27
200PHY	2" POLY PUMP W/12 HP HYDRAULIC MOTOR	12.0	1	18
200PHYW	2" POLY WET SEAL PUMP W/12 HP HYDRAULIC MOTOR	12.0	1	18



**WARNING! DO NOT RUN PUMP DRY, RESTRICT OR REDUCE PORT SIZES OR DEAD HEAD PUMP**



**WARNING! DO NOT USE WITH FLAMMABLE LIQUIDS**

### SPOOL VALVE ASSEMBLY DIAGRAM

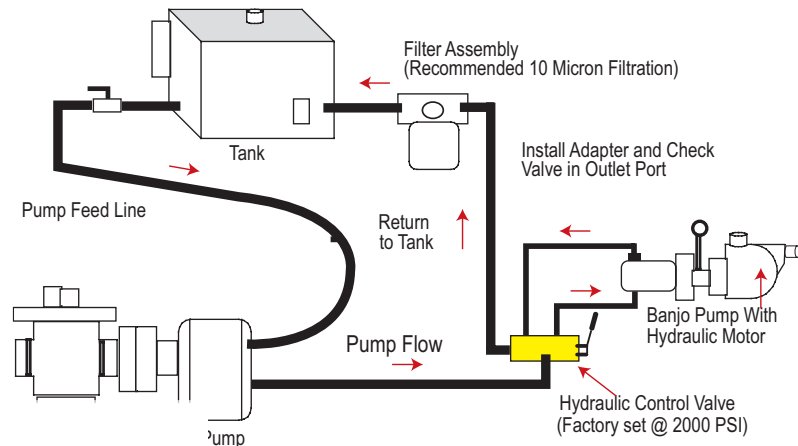

### HYDRAULIC MOTOR SPOOL VALVE

PART NO	DESCRIPTION	HP	QTY
HSV1000	HYDRAULIC MOTOR SPOOL VALVE	N/A	1

# CENTRIFUGAL PUMPS

## 2" POLY PUMPS WITH HYDRAULIC MOTORS

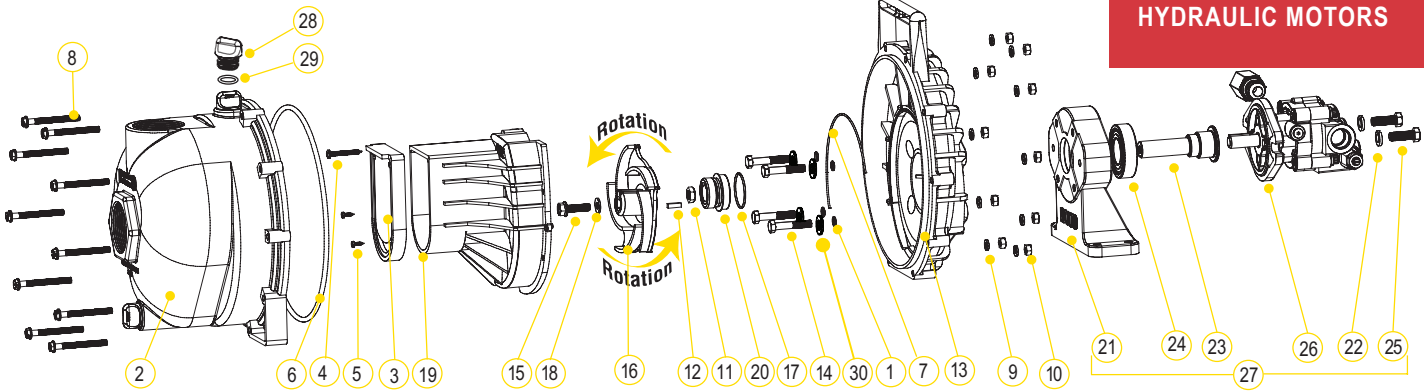

### REPLACEMENT PARTS 2" POLY PUMPS

ITEM	PART NO	DESCRIPTION	QTY
1	12717	O-RING FOR SCREW HEADS	4
2	12712A	BODY ASSEMBLY	1
3	12705	CHECK VALVE	1
4	12900	SS UPPER VOLUTE SCREW	1
5	12725	SS VOLUTE SCREWS	2
6	12719A	BODY O-RING	1
7	12754	O-RING SEGMENT	1
8	12720	SS BODY SCREWS	10
9	V07018	SS LOCK WASHERS	10
10	V07019	SS BODY NUTS	10
11	12775A	IMPELLER HEX NUT	1
12	12902A	IMPELLER KEY	1
13	12703A	POLY PUMP REAR BRACKET	1
14	12715A	5/16"-24 X 1.75" HHCS	4
15	12765A	SS IMPELLER BOLT	1
16	12772	5 VANE IMPELLER	1
17	12710	O-RING FOR SEAL ASSEMBLY	1
18	A204	O-RING	1
19	12702A	POLY PUMP VOLUTE	1
20	12713	MECHANICAL SEAL ASSEMBLY	1
21	12049F	HYDRAULIC PEDESTAL HOUSING	1
22	V20018	3/8" LOCK WASHER	2
23	12055E	ADAPTER SHAFT	1
24	17056E	BEARING	1
25	18010SS	3/8"-16 X 1.25" HHCS	2
26	HY1013	HYDRAULIC MOTOR	1
27	12600B	COMPLETE HYDRAULIC ASSEMBLY	1
28	12777	1/2" PLUG	2
29	UV15163	O-RING FOR PLUG	2
30	12901	WASHER (200PHA & 200PHY)	4
N/S	HY1003	HYDRAULIC MOTOR SEAL KIT	1
KIT	12000A	POLY PUMP EPDM REPAIR KIT (ITEMS 1, 3, 6, 7, 12, 16-18, 20, 12099)	1
KIT	12999A	PUMP SEAL/O-RING KIT (ITEMS 1, 6, 7, 17, 20, 29, 12099)	1

### KITS 2" POLY PUMPS

PART NO	EPDM REPAIR KIT NO	EPDM SEAL KIT NO	HYDRAULIC MOTOR SEAL KIT
200PHA	12000A	12999A	N/A
200PHY	12000A	12999A	HY1003

### HYDRAULIC MOTOR DATA

U.S. GALLONS/REV.	0.0025
CUBIC INCHES/REV.	0.580
LITERS/REV.	0.0097
MAX HYDRAULIC PRESSURE	2000 PSI
MIN HYDRAULIC PRESSURE	200 PSI
INLET PORT	SAE 10 (7/8-14 UNF-2B)
OUTLET PORT	SAE 10 (7/8-14 UNF-2B)
MINIMUM GPM REQUIRED	6 GPM 2400 RPM
MAXIMUM GPM REQUIRED	10 GPM 4000 RPM
IDEAL GPM REQUIRED	9 GPM 3600 RPM

### CONNECTION INFORMATION

INLET	"A" PORT
OUTLET	"B" PORT

SUPPLIED CHECK VALVE IS TO ENSURE PROPER ROTATION OF THE BANJO PUMP. PLACE CHECK VALVE IN OUTLET PORT (MARKED "B") FOR PROPER RIGHT HAND ROTATION.

### SPOOL VALVE INFORMATION

REQUIRED OUTLET FLOW	MIN 6 GPM / MAX 10 GPM
REQUIRED SYSTEM PRESSURE	MIN 600 PSI / MAX 3000 PSI

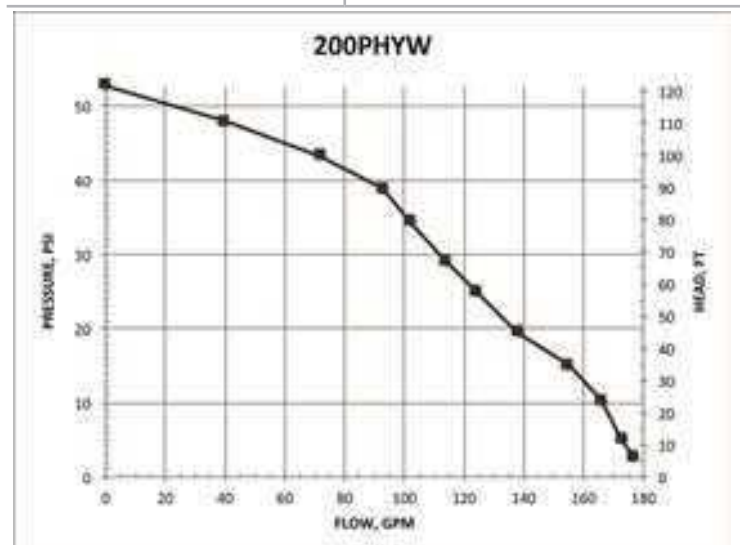

# CENTRIFUGAL PUMPS

## 2" POLY MANIFOLD PUMPS WITH GAS ENGINES

### FEATURES

- Precision molded construction
- Lightweight
- Corrosion resistant
- Low maintenance
- See pages 43-49 on manifold fittings for easy plumbing.



### 2" POLY MANIFOLD PUMPS W/GAS ENGINES

PART NO	DESCRIPTION	HP	QTY	SKID QTY
M220PH6	2" FP MANIFOLD PUMP W/6.5 HP HONDA® ENGINE	6.5	1	12
M220P6PRO	2" FP MANIFOLD PUMP W/6.5 HP BRIGGS & STRATTON® PRO SERIES ENGINE	6.5	1	12



WARNING! DO NOT RUN PUMP DRY, RESTRICT OR REDUCE PORT SIZES OR DEAD HEAD PUMP



WARNING! DO NOT USE WITH FLAMMABLE LIQUIDS



### 2" POLY MANIFOLD PUMP ONLY

PART NO	DESCRIPTION	HP	QTY	SKID QTY
M225PO	2" POLY MANIFOLD PUMP ONLY W/ 3/4" SHAFT & 5 VANE IMPELLER	N/A	1	27

# CENTRIFUGAL PUMPS

## 2" POLY MANIFOLD PUMPS WITH GAS ENGINES

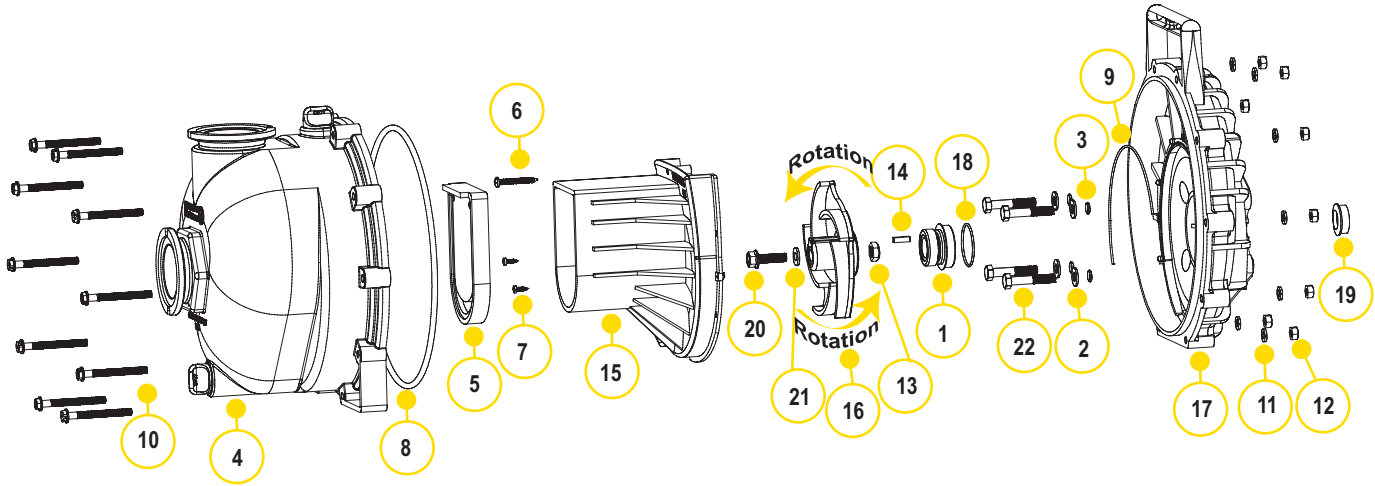

### REPLACEMENT PARTS 2" POLY PUMPS

ITEM	PART NO	DESCRIPTION	QTY
1	12713	MECHANICAL SEAL ASSEMBLY	1
2	12901	SS REAR BRACKET WASHER	4
3	12717	O-RING FOR SCREW HEAD	4
4	M12712	2" FP MANIFOLD PUMP BODY ASSEMBLY	1
5	12705	POLY PUMP CHECK VALVE	1
6	12900	SS UPPER VOLUTE SCREW	1
7	12725	SS VOLUTE SCREWS	2
8	12719A	BODY O-RING	1
9	12754	O-RING SEGMENT	1
10	12720	SS BODY SCREWS	10
11	V07018	SS LOCK WASHERS	10
12	V07019	SS BODY NUTS	10
13	12775A	IMPELLER HEX NUT	1
14	12902A	IMPELLER KEY	1
15	12702A	POLY PUMP VOLUTE	1
16	12772	5 VANE IMPELLER	1
16	12771A	3 VANE IMPELLER	1
17	12703A	POLY PUMP REAR BRACKET	1
18	12710	O-RING FOR SEAL ASSEMBLY	1
19	12716	POLY PUMP SLINGER	1
20	12765A	SS IMPELLER BOLT	1
21	A204	O-RING	1
22	12715A	SS BRACKET SCREWS	4
KIT	12000A	POLY PUMP EPDM REPAIR KIT (ITEMS 2,4,7,8,14, 17,19,21,30, 12099)	1
KIT	12000AV	POLY PUMP FKM REPAIR KIT (ITEMS 2,4,7,8,14, 17,19,21,30, 12099)	1
KIT	12999A	PUMP SEAL/O-RING KIT (ITEMS 2,4,7,8,17,19,21,30, 12099)	1
KIT	12999AV	FKM PUMP SEAL/O-RING KIT (ITEMS 4-7,8,10,18, 23 & 12099)	1

### KITS 2" POLY PUMPS

PART NO	EPDM REPAIR KIT NO	FKM REPAIR KIT NO	EPDM SEAL KIT NO	FKM SEAL KIT NO
M220PH6	12000A	12000AV	12999A	12999AV
M220P6PRO	12000A	12000AV	12999A	12999AV
M225PO	12000A	12000AV	12999A	12999AV

SEE 12000A & 12000AV KIT DRAWING ON PAGE 107

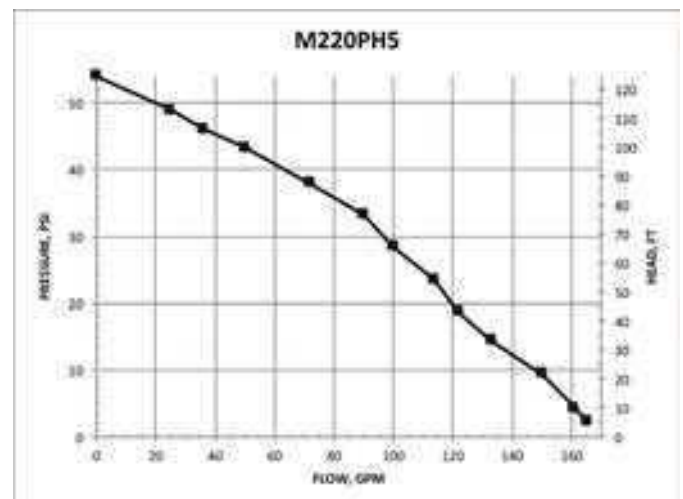

# CENTRIFUGAL PUMPS

## 2" POLY MANIFOLD WET SEAL PUMPS

### FEATURES

- Run dry capability
- Double seal contained in ethylene glycol reservoir. Carbon ceramic seal faces with stainless steel cup and spring with EPDM rubber
- Pump end separated from engine
- Large weep holes between pump and engine
- V-shaped for quicker priming
- See pages 43-49 on manifold fittings for easy plumbing.



### 2" POLY MANIFOLD WET SEAL PUMPS W/GAS ENGINES

PART NO	DESCRIPTION	HP	QTY	SKID QTY
M220PH6W	2" POLY MANIFOLD WET SEAL PUMP W/6.5 HP HONDA® ENGINE	5.5	1	12



WARNING! DO NOT RUN PUMP DRY, RESTRICT OR REDUCE PORT SIZES OR DEAD HEAD PUMP



WARNING! DO NOT USE WITH FLAMMABLE LIQUIDS

# CENTRIFUGAL PUMPS

2" POLY MANIFOLD WET SEAL PUMPS

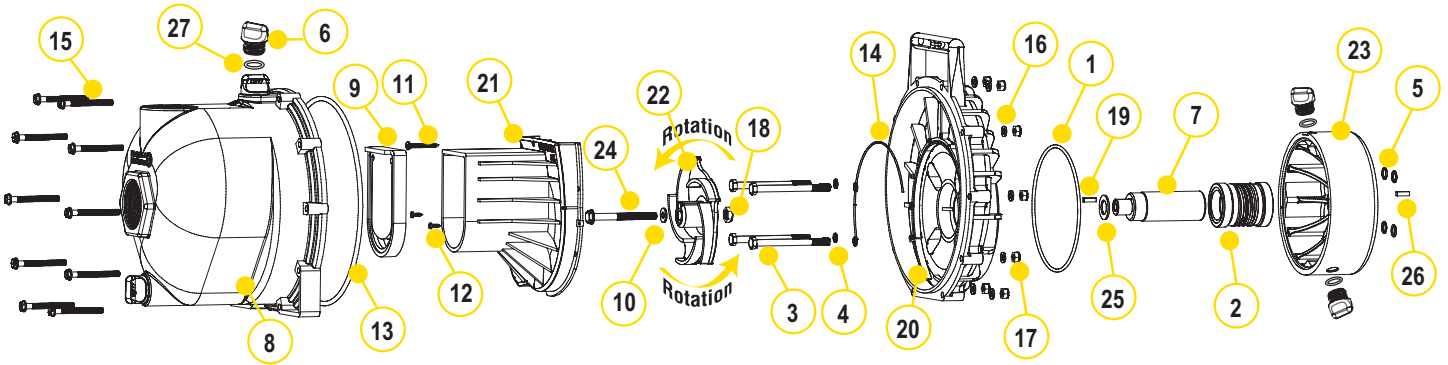

## REPLACEMENT PARTS 2" POLY PUMPS

ITEM	PART NO	DESCRIPTION	QTY
1	13719	O-RING	1
2	15035E	EPDM MECHANICAL SEAL ASSEMBLY	1
3	13034	5/16" -24 X 3 3/4" HHCS	4
4	12717	O-RING FOR BRACKET SCREW	4
5	12709	O-RING	4
6	12777	1/2" PLUG	4
7	12155	ADAPTER SHAFT	1
8	M12712	2" FP MANIFOLD PUMP BODY ASSEMBLY	1
9	12705	CHECK VALVE	1
10	A204	IMPELLER BOLT GASKET	1
11	12900	#10 X 1 1/2" PPH SMS	1
12	12725	#6 X 1/2" PPH SMS	2
13	12719A	BODY O-RING	1
14	12754	O-RING SEGMENT	1
15	12720	1/4" - 20 X 2 1/2" SL IND HWHS	10
16	V07018	1/4" LOCK WASHER	10
17	V07019	1/4" - 20 HEX NUT	10
18	12775A	7/16" - 14 HEX NUT	1
19	12902A	3/16" SQ. X 5/8" KEY	2
20	12707W	WET SEAL REAR BRACKET	1
21	12702A	VOLUTE	1
22	12772	5 VANE IMPELLER	1
23	12202W	WET SEAL RESERVOIR	1
24	12766	5/16" - 24 X 3 3/4" HFS	1
25	CV10175	GASKET	1
26	12902A	1/4" SQ. 3/4" KEY STOCK	1
27	UV15163	O-RING FOR DRAIN PLUG	4
KIT	12000AW	CONTAINS # 1, 2, 4, 5, 9, 10, 13, 14, 22, 25, 27	1

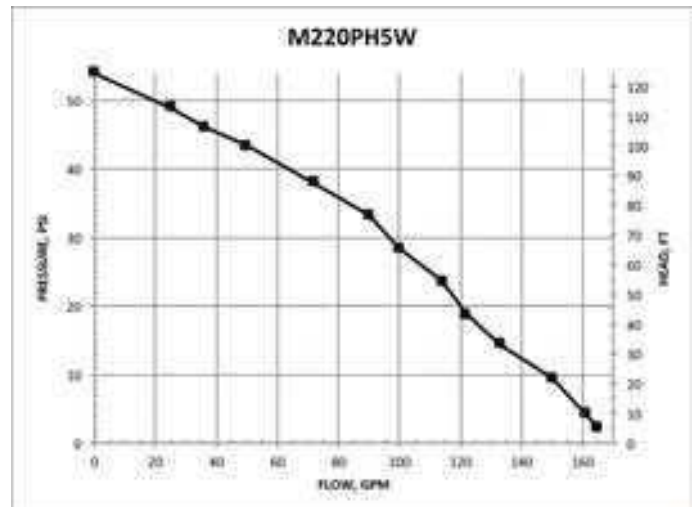

# CENTRIFUGAL PUMPS

## 3" POLY PUMPS

### FEATURES

- Large weep holes between pump and engine
- V-shaped for quicker priming
- Pump only comes unassembled



### 3" POLY PUMPS W/GAS ENGINES

PART NO	DESCRIPTION	HP	QTY	SKID QTY
300P6PRO	3" POLY PUMP W/6.5 HP BRIGGS & STRATTON® ENGINE	6.5	1	12
300PH-6	3" POLY PUMP W/6.5 HP HONDA® ENGINE	6.5	1	12
300P11PRO	3" POLY PUMP W/11 HP BRIGGS & STRATTON® ENGINE PRO SERIES W/ELECTRIC START & PULL ROPE	11	1	8



WARNING! DO NOT RUN PUMP DRY, RESTRICT OR REDUCE PORT SIZES OR DEAD HEAD PUMP



WARNING! DO NOT USE WITH FLAMMABLE LIQUIDS



### 3" POLY BEARING PEDESTAL

PART NO	DESCRIPTION	HP	QTY	SKID QTY
300PB	3" POLY BEARING PEDESTAL W/ 3/4" SHAFT & 4 VANE IMPELLER	N/A	1	18



### 3" POLY PUMP ONLY

PART NO	DESCRIPTION	HP	QTY	SKID QTY
300PO	3" POLY PUMP ONLY W/ 3/4" SHAFT & 4 VANE IMPELLER	N/A	1	27

# CENTRIFUGAL PUMPS

## 3" POLY PUMPS

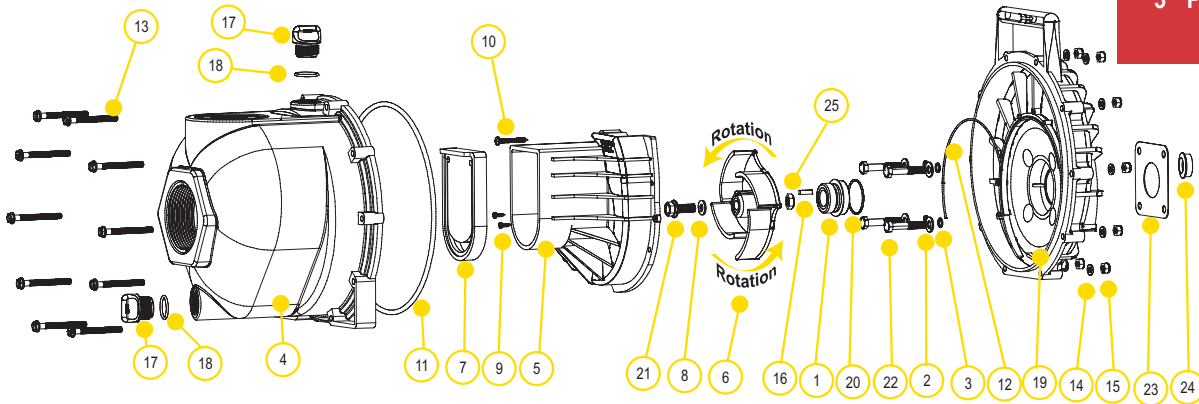

### REPLACEMENT PARTS 3" POLY PUMPS

ITEM	PART NO	DESCRIPTION	QTY
1	12713	SEAL ASSEMBLY	1
2	12901	SS REAR BRACKET WASHER	1
3	12717	O-RING FOR SCREW HEAD	1
4	13712	BODY ASSEMBLY	1
5	13702	POLY PUMP VOLUTE	1
6	13771	4 VANE TRIMMED IMPELLER (300PH-6, 300PB & 300PO)	1
6	13772	4 VANE IMPELLER (300P11PRO)	1
7	12705	CHECK VALVE	1
8	A204	O-RING	1
9	12900	SS UPPER VOLUTE SCREW	1
10	12725	SS VOLUTE SCREWS	1
11	12719A	BODY O-RING	1
12	12754	O-RING SEGMENT	1
13	12720	SS BODY SCREWS	1
14	V07018	SS LOCK WASHERS	1
15	V07019	SS BODY NUTS	1
16	12902A	IMPELLER KEY	1
17	13777	3/4" PLUG	1
18	13778	O-RING	1
19	12703A	POLY PUMP REAR BRACKET	1
20	12710	O-RING FOR SEAL ASSEMBLY	1
21	12765A	SS IMPELLER BOLT 5/16 X 24 X 1.12 (300PH-6)	1
21	13765	SS IMPELLER BOLT 3/8 X 24 X 1.75 (300P11PRO)	1
22	12715A	SS BRACKET SCREWS	1
23	15751	REAR BRACKET SHIM	1
24	12716	POLY PUMP SLINGER	1
25	12775A	IMPELLER HEX NUT	1
N/S	12882A	BEARING PEDESTAL	1
N/S	12099	7/16"-14 X 1.25" HHCS	1
N/S	12000A	POLY PUMP EPDM REPAIR KIT (ITEMS 1, 3, 6-8, 11, 12, 16, 18, 20, 24 & 12099)	1
N/S	13999	PUMP SEAL/O-RING KIT (ITEMS 1, 3, 8, 11, 12, 18, 20, 24 & 12099)	1

### KITS 3" POLY PUMPS

PART NO	EPDM REPAIR KIT NO	EPDM SEAL KIT NO
300PH-6	12000A	13999
300P11PRO	12000A	13999
300PB	12000A	13999
300PO	12000A	13999

SEE 12000A KIT DRAWING ON PAGE 107

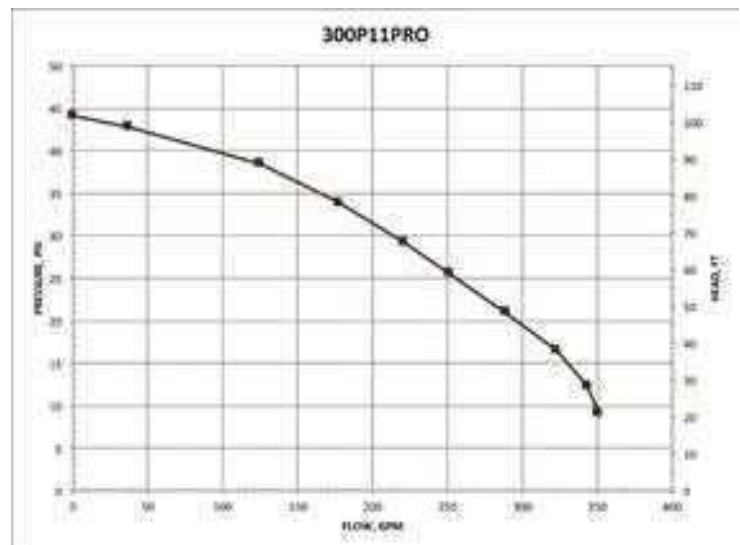

# CENTRIFUGAL PUMPS

## 3" POLY MANIFOLD PUMPS

### FEATURES

- Large weep holes between pump and engine
- V-shaped for quicker priming
- Pump only comes unassembled
- See pages 43-49 on manifold fittings for easy plumbing.



POWERED by  
**HONDA**

### 3" POLY MANIFOLD PUMPS W/GAS ENGINES

PART NO	DESCRIPTION	HP	QTY	SKID QTY
M300PH6	3" POLY MANIFOLD PUMP W/6.5 HP HONDA® ENGINE	6.5	1	12
M300P11PRO	3" POLY MANIFOLD PUMP W/11 HP BRIGGS & STRATTON® PRO SERIES W/ELECTRIC START & PULL ROPE	11	1	12



WARNING! DO NOT RUN PUMP DRY, RESTRICT OR REDUCE PORT SIZES OR DEAD HEAD PUMP



WARNING! DO NOT USE WITH FLAMMABLE LIQUIDS



### 3" POLY MANIFOLD BEARING PEDESTAL

PART NO	DESCRIPTION	HP	QTY	SKID QTY
M300PB	3" POLY MANIFOLD BEARING PEDESTAL W/ 3/4" SHAFT & 4 VANE IMPELLER	N/A	1	18



### 3" POLY MANIFOLD PUMP ONLY

PART NO	DESCRIPTION	HP	QTY	SKID QTY
M300PO	3" POLY MANIFOLD PUMP ONLY W/ 3/4" SHAFT & 4 VANE IMPELLER	N/A	1	27

# CENTRIFUGAL PUMPS

## 3" POLY MANIFOLD PUMPS

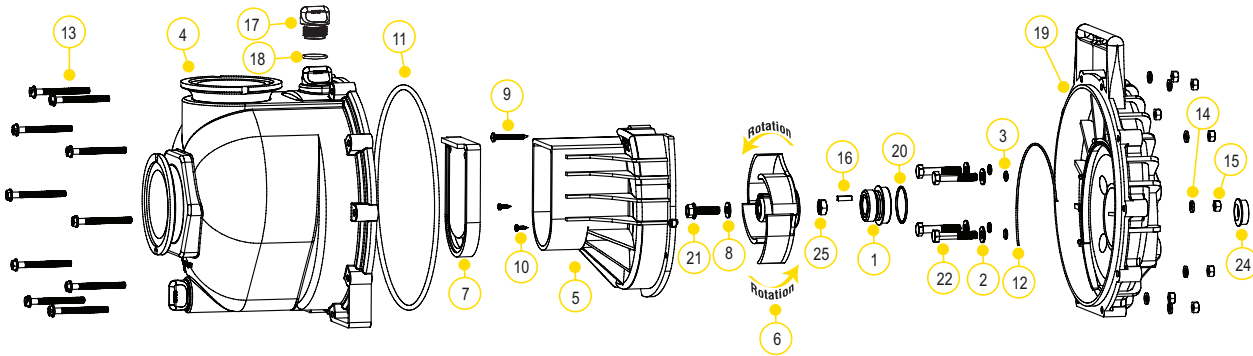

### REPLACEMENT PARTS 3" POLY MANIFOLD PUMPS

ITEM	PART NO	DESCRIPTION	QTY
1	12713	SEAL ASSEMBLY	1
2	12901	SS REAR BRACKET WASHER	4
3	12717	O-RING FOR SCREW HEAD	4
4	M13712	MANIFOLD BODY ASSEMBLY	1
5	13702	POLY PUMP VOLUTE	1
6	13771	4 VANE TRIMMED IMPELLER (M300PH-6, M300PB & M300PO)	1
6	13772	4 VANE IMPELLER (M300P11PRO)	1
7	12705	CHECK VALVE	1
8	A204	O-RING	1
9	12900	SS UPPER VOLUTE SCREW	4
10	12725	SS VOLUTE SCREWS	2
11	12719A	BODY O-RING	1
12	12754	O-RING SEGMENT	1
13	12720	SS BODY SCREWS	10
14	V07018	SS LOCK WASHERS	10
15	V07019	SS BODY NUTS	10
16	12902A	IMPELLER KEY	1
17	13777	3/4" PLUG	2
18	13778	O-RING	2
19	12703A	POLY PUMP REAR BRACKET	1
20	12710	O-RING FOR SEAL ASSEMBLY	1
21	12765A	SS IMPELLER BOLT 5/16 X 24 X 1.12 (-6)	1
21	13765	SS IMPELLER BOLT 3/8 X 24 X 1.75 (M300P11PRO)	1
22	12715A	SS BRACKET SCREWS	4
23	15751	REAR BRACKET SHIM	1
24	12716	POLY PUMP SLINGER	1
25	12775A	IMPELLER HEX NUT	1
N/S	12882A	BEARING PEDESTAL	1
N/S	12099	7/16"-14 X 1.25" HHCS	1
N/S	12000A	POLY PUMP EPDM REPAIR KIT (ITEMS 1, 3, 6-8, 11, 12, 16, 18, 20, 24 & 12099)	1
N/S	13999	PUMP SEAL/O-RING KIT (ITEMS 1, 3, 8, 11, 12, 18, 20, 24 & 12099)	1

### KITS 3" POLY PUMPS

PART NO	EPDM REPAIR KIT NO	EPDM SEAL KIT NO
M300PH6	12000A	13999
M300P11PRO	12000A	13999
M300PB	12000A	13999
M300PO	12000A	13999

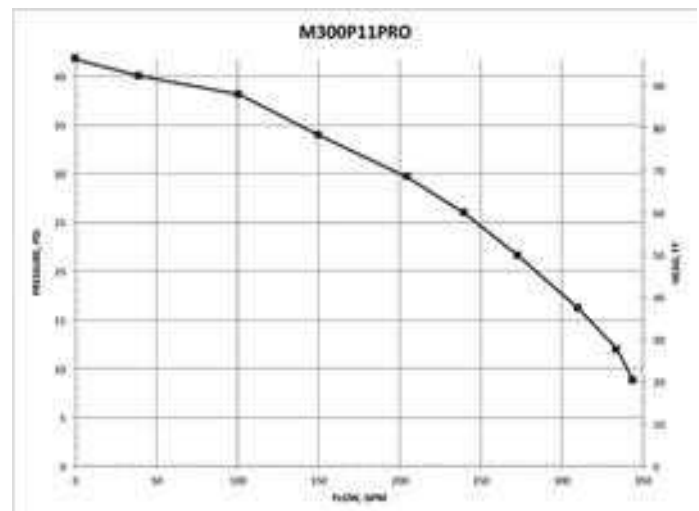

# CENTRIFUGAL PUMPS

## 3" POLY PUMPS WITH HYDRAULIC MOTORS

### FEATURES

- Precision molded construction
- Lightweight
- Corrosion resistant
- Low maintenance
- Hydraulic fluid capacity is minimum 6 gallons and maximum 10 gallons
- Open or closed system
- 3600 R.P.M.
- Recommendation to use the motor spool control valve or a suitable equivalent. The lack of such a valve in this circuit may cause failure to the hydraulic motor and will void warranty.



### 3" POLY PUMPS W/HYDRAULIC MOTORS

PART NO	DESCRIPTION	HP	QTY	SKID QTY
300PHY	3" POLY PUMP W/12 HP H HYDRAULIC MOTOR	12	1	18



**WARNING! DO NOT RUN PUMP DRY, RESTRICT OR REDUCE PORT SIZES OR DEAD HEAD PUMP**



**WARNING! DO NOT USE WITH FLAMMABLE LIQUIDS**

### SPOOL VALVE ASSEMBLY DIAGRAM

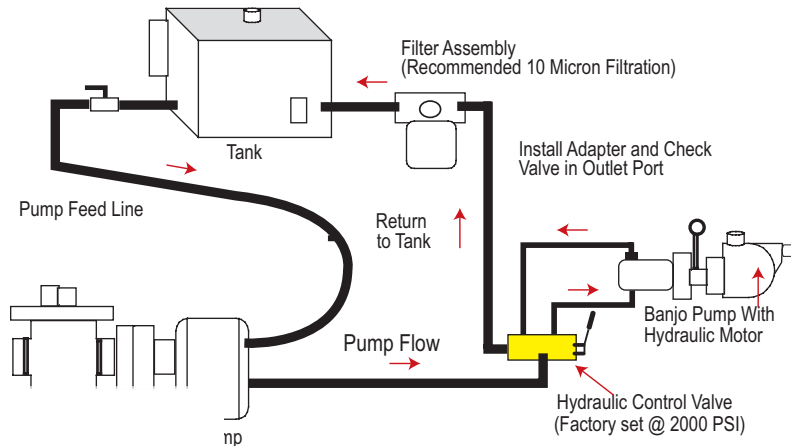

### HYDRAULIC MOTOR SPOOL VALVE

PART NO	DESCRIPTION	HP	QTY
HSV1000	HYDRAULIC MOTOR SPOOL VALVE	N/A	1

# CENTRIFUGAL PUMPS

## 3" POLY PUMPS WITH HYDRAULIC MOTORS

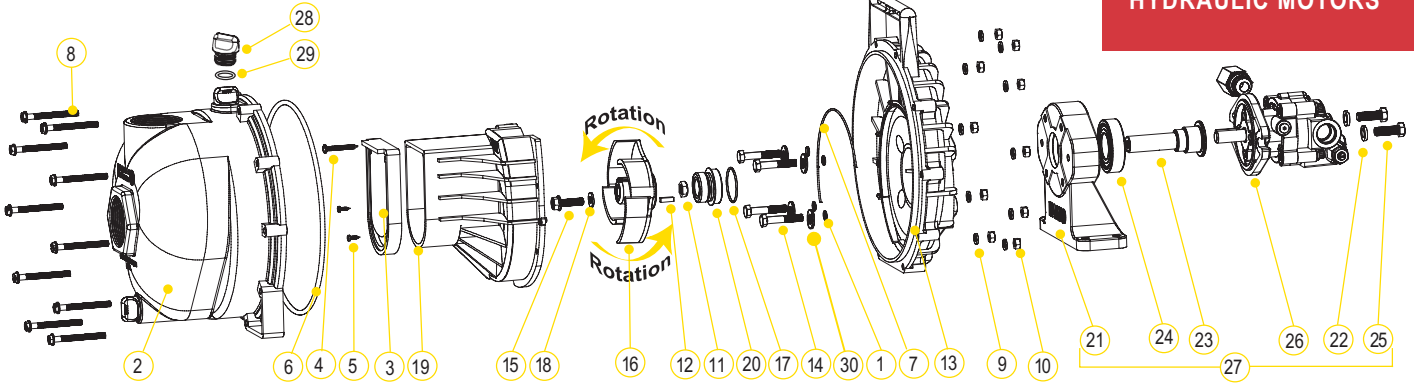

### REPLACEMENT PARTS 3" POLY PUMPS

ITEM	PART NO	DESCRIPTION	QTY
1	12717	O-RING FOR SCREW HEADS	4
2	13712	BODY ASSEMBLY	1
3	12705	CHECK VALVE	1
4	12900	SS UPPER VOLUTE SCREW	4
5	12725	SS VOLUTE SCREWS	2
6	12719A	BODY O-RING	1
7	12754	O-RING SEGMENT	1
8	12720	SS BODY SCREWS	10
9	V07018	SS LOCK WASHERS	10
10	V07019	SS BODY NUTS	10
11	12775A	IMPELLER HEX NUT	1
12	12902A	IMPELLER KEY	1
13	12703A	POLY PUMP REAR BRACKET	1
14	12715A	5/16"-24 X 1.75" HHCS	4
15	12765A	SS IMPELLER BOLT	1
16	13772	TRIMMED 4 VANE IMPELLER	1
17	12710	O-RING FOR SEAL ASSEMBLY	1
18	A204	O-RING	1
19	13702	POLY PUMP VOLUTE	1
20	12713	MECHANICAL SEAL ASSEMBLY	1
21	12049F	HYDRAULIC PEDESTAL HOUSING (MUST ORDER 17056E & 12055E)	1
22	V20018	3/8" LOCK WASHER	2
23	12055E	ADAPTER SHAFT	1
24	17056E	BEARING	1
25	18010SS	3/8" - 16 X 1 1/8" SS CAP SCREW HXHD	2
26	HY1013	HYDRAULIC MOTOR	1
27	12600B	COMPLETE HYDRAULIC ASSEMBLY	1
28	13777	3/4" PLUG	2
29	13778	O-RING	2
30	12901	SS REAR BRACKET WASHER (300PHY)	4
N/S	HY1003	HYDRAULIC MOTOR SEAL KIT	1
KIT	12000A	POLY PUMP EPDM REPAIR KIT (ITEMS 1, 3, 6, 7, 16, 18, 20, 29, 12099)	1
KIT	13999	PUMP SEAL/O-RING KIT (ITEMS 2,4,7-8,16,18,19, 21, 30, 12099)	1

### KITS 3" POLY PUMPS

PART NO	EPDM REPAIR KIT NO	EPDM SEAL KIT NO	HYDRAULIC MOTOR SEAL KIT
300PHY	12000A	13999	HY1003

### HYDRAULIC MOTOR DATA

U.S. GALLONS/REV.	0.0025
CUBIC INCHES/REV.	0.580
LITERS/REV.	0.0097
MAX HYDRAULIC PRESSURE	2000 PSI
MIN HYDRAULIC PRESSURE	200 PSI
INLET PORT	SAE 10 (7/8-14 UNF-2B)
OUTLET PORT	SAE 10 (7/8-14 UNF-2B)
MINIMUM GPM REQUIRED	6 GPM 2400 RPM
MAXIMUM GPM REQUIRED	10 GPM 4000 RPM
IDEAL GPM REQUIRED	9 GPM 3600 RPM

### CONNECTION INFORMATION

INLET	"A" PORT
OUTLET	"B" PORT
SUPPLIED CHECK VALVE IS TO ENSURE PROPER ROTATION OF THE BANJO PUMP. PLACE CHECK VALVE IN OUTLET PORT (MARKED "B") FOR PROPER RIGHT HAND ROTATION.	

### SPOOL VALVE INFORMATION

REQUIRED OUTLET FLOW	MIN 6 GPM / MAX 10 GPM
REQUIRED SYSTEM PRESSURE	MIN 600 PSI / MAX 3000 PSI

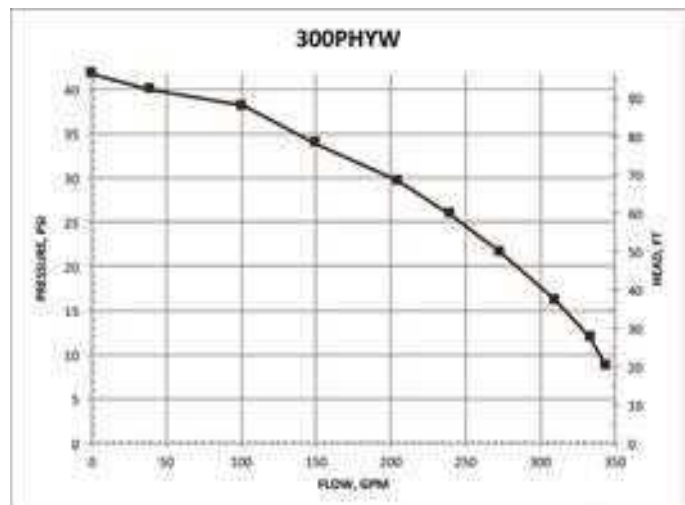

# CENTRIFUGAL PUMPS

## 3" POLY WET SEAL PUMPS

### FEATURES

- Run dry capability
- Double seal contained in ethylene glycol reservoir. Carbon ceramic seal faces with stainless steel cup and spring with EPDM rubber.
- V-shaped for quicker priming
- Engine warranty service available at authorized Briggs & Stratton® and Honda® dealers
- Due to weight and size of pumps, Banjo ships these by truck only.



WARNING! DO NOT USE WITH FLAMMABLE LIQUIDS

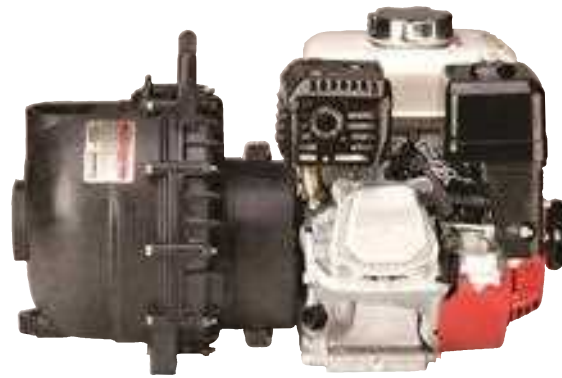

### 3" POLY WET SEAL PUMPS W/GAS ENGINES

PART NO	DESCRIPTION	HP	QTY	SKID QTY
300PH6W	3" POLY WET SEAL PUMP W/6 HP HONDA® ENGINE	6	1	12
300P11PROW	3" POLY WET SEAL PUMP W/11 HP BRIGGS & STRATTON® ENGINE PRO SERIES W/ELECTRIC START & PULL ROPE	11	1	8
300PH13W	3" POLY WET SEAL PUMP W/13 HP HONDA® ENGINE W/ELECTRIC START & PULL ROPE	13	1	8



### 3" POLY WET SEAL BEARING PEDESTAL

PART NO	DESCRIPTION	HP	QTY	SKID QTY
300PBW	3" POLY WET SEAL BEARING PEDESTAL W/ 3/4" SHAFT & 4 VANE IMPELLER	N/A	1	27



### 3" POLY WET SEAL PUMP ONLY

PART NO	DESCRIPTION	HP	QTY	SKID QTY
300POW	3" POLY WET SEAL PUMP ONLY FOR 1" SHAFT	N/A	1	27
300POW6	3" POLY WET SEAL PUMP ONLY FOR 3/4" SHAFT	N/A	1	27

# CENTRIFUGAL PUMPS

## 3" POLY WET SEAL PUMPS

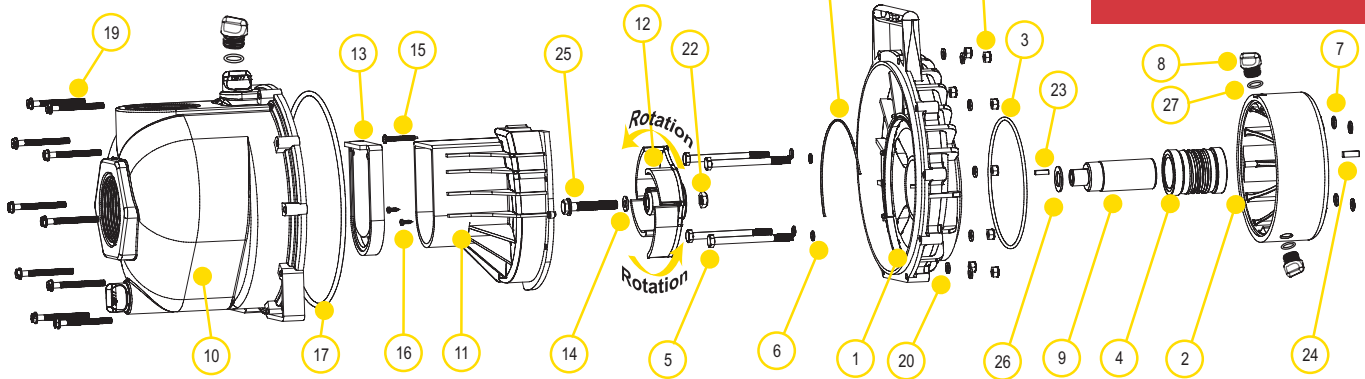

### REPLACEMENT PARTS 3" POLY PUMPS

ITEM	PART NO	DESCRIPTION	QTY
1	12703AW	WET SEAL REAR BRACKET	1
2	12201W	WET SEAL RESERVOIR	1
2	12202W	WET SEAL RESERVOIR (300POW6)	1
3	13719	O-RING	1
3	13719V	FKM O-RING (301POWV)	1
4	15035E	EPDM MECHANICAL SEAL ASSEMBLY	1
4	15035	MECHANICAL SEAL ASSEMBLY (301POWV)	1
5	13034	5/16" -24 X 3 3/4" HHCS	4
6	12717	O-RING FOR BRACKET SCREW	4
6	12717V	FKM O-RING FOR BRACKET SCREW (301POWV)	4
7	12709	O-RING	4
7	12709V	FKM O-RING (301POWV)	4
8	12777	1/2" PLUG	4
9	13055	ADAPTER SHAFT (300PH6W & 300PH13W)	1
9	N/A	ADAPTER SHAFT (300P11PROW & 301POWV)	1
9	12155	ADAPTER SHAFT (300PH6W)	1
10	13712	BODY ASSEMBLY	1
10	13712	FKM BODY ASSEMBLY (301POWV)	1
11	13702	VOLUTE	1
12	13772	4 VANE IMPELLER	1
12	13771	TRIMMED IMPELLER (300POW6)	1
13	12705	CHECK VALVE	1
13	12705V	FKM CHECK VALVE (301POWV)	1
14	A204	IMPELLER BOLT GASKET	1
14	A204V	FKM IMPELLER BOLT GASKET (301POWV)	1
15	12900	#10 X 1 1/2" PPH SMS	1
16	12725	#6 X 1/2" PPH SMS	2
17	13719	BODY O-RING	1
17	13719V	FKM BODY O-RING (301POWV)	1
18	12754	O-RING SEGMENT	1
18	12754V	FKM O-RING SEGMENT (301POWV)	1
19	12720	1/4" - 20 X 2 1/2" SL IND HWHS	10
20	V07018	1/4" LOCK WASHER	10
21	V07019	1/4" - 20 HEX NUT	10
22	12775A	7/16" - 14 HEX NUT	1
23	12902A	3/16" SQ. X 5/8" KEY	2
24	16901	1/4" SQUARE KEY	1
25	13766	3/8"-24 X 2 1/4" HFS	1

### REPLACEMENT PARTS 3" POLY PUMPS

ITEM	PART NO	DESCRIPTION	QTY
26	CV10175	GASKET	1
26	CV10175V	FKM GASKET (301POWV)	1
27	UV15163	O-RING FOR DRAIN PLUG	4
27	UV15163V	FKM O-RING FOR DRAIN PLUG (301POWV)	4
N/S	18135A	Z-RAIL (HALF OF PAIR) USED ON 13 HP MODELS	1
N/S	18135B	Z-RAIL (HALF OF PAIR) USED ON 13 HP MODELS	1
KIT	12000AW	CONTAINS # 3, 4, 6, 7, 12, 13, 14, 17, 18, 26, 27	1

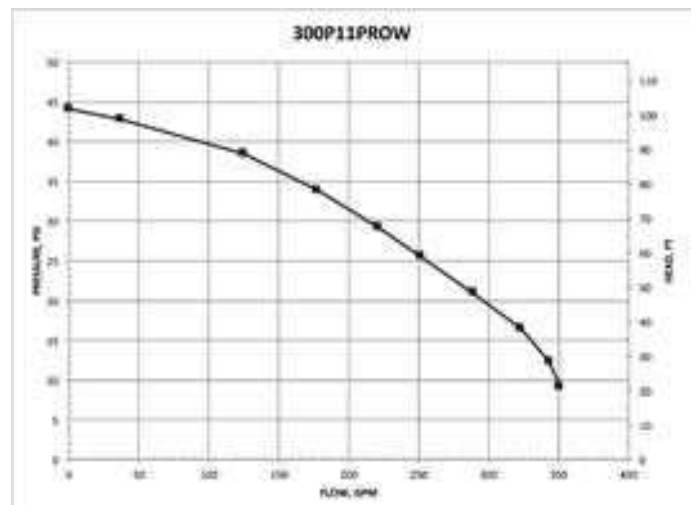

# CENTRIFUGAL PUMPS

## 3" POLY MANIFOLD WET SEAL PUMPS

### FEATURES

- Run dry capability
- Double seal contained in ethylene glycol reservoir. Carbon ceramic seal faces with stainless steel cup and spring with EPDM rubber
- Pump end separated from engine
- V-shaped for quicker priming
- Engine warranty service available at authorized dealers
- See pages 43-49 on manifold fittings for easy plumbing.



### 3" POLY MANIFOLD WET SEAL PUMPS W/GAS ENGINES

PART NO	DESCRIPTION	HP	QTY	SKID QTY
M300PH6W	3" POLY MANIFOLD WET SEAL PUMP W/6 HP HONDA® ENGINE	6	1	12



### 3" POLY MANIFOLD WET SEAL PUMP ONLYS

PART NO	DESCRIPTION	HP	QTY	SKID QTY
M300POW6	3" POLY MANIFOLD WET SEAL PUMP ONLY FOR ¾" SHAFT	N/A	1	27



### 3" POLY MANIFOLD WET SEAL PUMP W/HYDRAULIC

PART NO	DESCRIPTION	HP	QTY	SKID QTY
M305PHYW	3" POLY MANIFOLD WET SEAL PUMP W/HYDRAULIC MOTOR	N/A	1	12



WARNING! DO NOT USE WITH FLAMMABLE LIQUIDS

# CENTRIFUGAL PUMPS

## 3" POLY MANIFOLD WET SEAL PUMPS

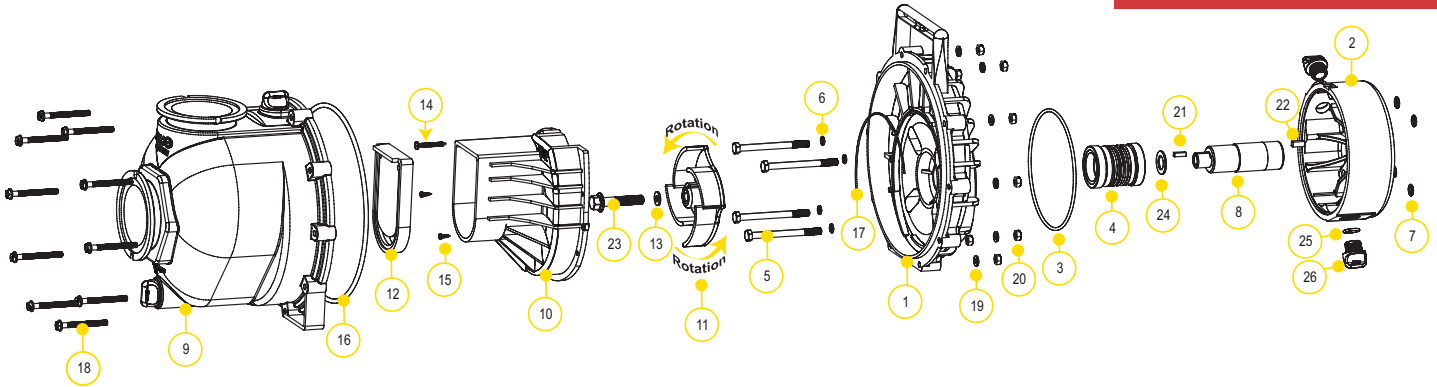

### REPLACEMENT PARTS 3" POLY PUMPS

ITEM	PART NO	DESCRIPTION	QTY
1	12707W	WET SEAL REAR BRACKET FOR 6 HP HONDA® ENGINE & BEARING PEDESTAL	1
2	12202W	WET SEAL RESERVOIR FOR 6 HP HONDA® ENGINE & BEARING PEDESTAL	1
3	13719	O-RING	1
4	15035E	MECHANICAL SEAL ASSEMBLY EPDM	1
5	13034	5/16" - 24 X 3 3/4" HHCS	4
6	12717	O-RING FOR BRACKET SCREW	4
7	12709	O-RING	4
8	12155	ADAPTER SHAFT FOR 6 HP HONDA® ENGINE & BEARING PEDESTAL	1
9	M13712	MANIFOLD BODY ASSEMBLY	1
10	13702	VOLUTE	1
11	13771	4 VANE IMPELLER	1
11	13772A	5 VANE IMPELLER (M305PHYW) (NOT IN REPAIR KIT)	1
12	12705	CHECK VALVE	1
13	A204	O-RING	1
14	12900	#10 X 1 1/2" PPH SMS 18-8 SS	1
15	12725	#6 X 1/2" PPH SMS 18-8 SS	1
16	12719A	BODY O-RING	1
17	12754	O-RING SEGMENT	1
18	12720	1/4" - 20 X 2 1/2" SL IND HWHS	10
19	V07018	1/4" LOCK WASHER	10
20	V07019	1/4" - 20 HEX NUT	10
21	12902A	3/16" SQ. X 5/8" KEY	1
22	16901	1/4" SQ. 3/4" KEY STOCK	1
23	12766	5/16"-24 X 3 3/4" HFS FOR 6 HP HONDA® ENGINE & BEARING PEDESTAL	1
24	CV10175	GASKET	1
25	UV15163	O-RING	2
26	12777	1/2" PLUG	2
KIT	<b>12000AW</b>	CONTAINS # 3, 4, 6, 7, 11, 12, 13, 16, 17, 24, 25	1



# CENTRIFUGAL PUMPS

## 3" POLY M350 MANIFOLD WET SEAL PUMPS

### FEATURES

- 500+ Gallons per Minute
- Polymer components molded from polypropylene
- EPDM seals
- All stainless steel hardware
- Tandem wet seal design
- Produces less wear
- Prevents seal breakage from high pressure clean out
- Eliminates eight leak points
- Works with natural system pressure to keep seal intact
- No exposed moving parts
- Typical operating speed: 3600 RPM
- Run dry capability of greater than one hour.
- Capable of handling occasional solid particles in suspension up to 1/2" in diameter.
- Maximum self-priming height 25 ft (7.6 m) for hydraulic version
- (0.422" priming hole); 28 ft (8.5 m) for standard version (0.250" priming hole)
- Engine warranty service available at authorized dealers
- See pages 43-49 on manifold fittings for easy plumbing.



### 3" POLY MANIFOLD WET SEAL PUMPS W/GAS ENGINES

PART NO	DESCRIPTION	HP	QTY	SKID QTY
M350PH13W	3" POLY MANIFOLD WET SEAL PUMP W/13 HP HONDA® ENGINE	13	1	6



### 3" POLY MANIFOLD WET SEAL PUMP ONLYS

PART NO	DESCRIPTION	HP	QTY	SKID QTY
M350POW	3" POLY MANIFOLD WET SEAL PUMP ONLY FOR 1" SHAFT GAS ENGINES	N/A	1	27

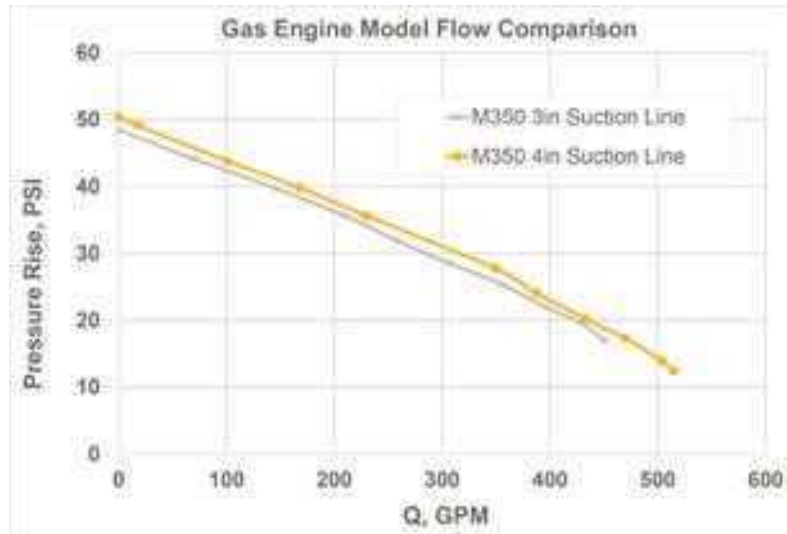

### OPTIMIZE FLOW WITH 4" SUCTION



### 4" PLUMBING FITTINGS

PART NO	DESCRIPTION	LOT QTY
M300400A	3" Manifold x 4" Male Coupler	1
M300400BRB	3" Manifold x 4" Hose Barb	1

## 3" POLY M350 MANIFOLD WET SEAL PUMPS

### FEATURES

- 500+ Gallons per Minute
- Polymer components molded from polypropylene
- EPDM seals
- All stainless steel hardware
- Tandem wet seal design
- Produces less wear
- Prevents seal breakage from high pressure clean out
- Eliminates eight leak points
- Works with natural system pressure to keep seal intact
- No exposed moving parts
- Typical operating speed: 3600 RPM
- Run dry capability of greater than one hour.
- Capable of handling occasional solid particles in suspension up to 1/2" in diameter.
- Maximum self-priming height 25 ft (7.6 m) for hydraulic version
- (0.422" priming hole); 28 ft (8.5 m) for standard version (0.250" priming hole)
- Engine warranty service available at authorized dealers
- See pages 43-49 on manifold fittings for easy plumbing.



**WARNING! DO NOT USE WITH FLAMMABLE LIQUIDS**



### 3" POLY MANIFOLD WET SEAL PUMP W/ELECTRIC MOTOR

PART NO	DESCRIPTION	HP	QTY	SKID QTY
M350PE15W	3" POLY MANIFOLD WET SEAL PUMP W/15 HP 3 PHASE ELECTRIC MOTOR	15	1	1



### 3" POLY MANIFOLD WET SEAL PUMP ONLYS

PART NO	DESCRIPTION	HP	QTY	SKID QTY
M350PEOW	3" POLY MANIFOLD WET SEAL PUMP ONLY FOR ELECTRIC MOTOR	N/A	1	27



### 3" POLY WET SEAL BEARING PEDESTAL

PART NO	DESCRIPTION	HP	QTY	SKID QTY
M350PBW	3" POLY WET SEAL BEARING PEDESTAL W/ 1" SHAFT & 4 VANE IMPELLER	N/A	1	12

# CENTRIFUGAL PUMPS

## 3" POLY M350 MANIFOLD WET SEAL PUMPS



### 3" POLY MANIFOLD WET SEAL PUMP W/HYDRAULIC

PART NO	DESCRIPTION	HP	QTY	SKID QTY
M350PHYW	3" POLY MANIFOLD WET SEAL PUMP W/HYDRAULIC MOTOR	N/A	1	12



### 3" POLY MANIFOLD WET SEAL PUMP W/HYD PEDESTAL

PART NO	DESCRIPTION	HP	QTY	SKID QTY
M350PHAW	3" POLY MANIFOLD WET SEAL PUMP W/HYDRAULIC PEDESTAL (NO MOTOR)	N/A	1	12

## SPOOL VALVE ASSEMBLY DIAGRAM

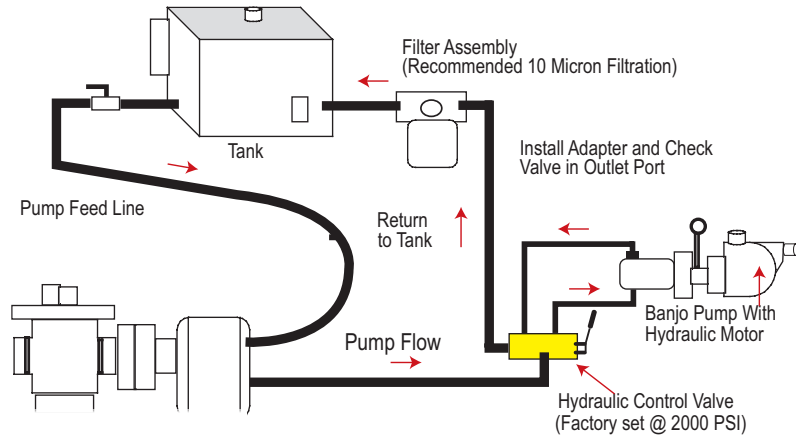

### HYDRAULIC MOTOR SPOOL VALVE

PART NO	DESCRIPTION	HP	QTY
HSV1000	HYDRAULIC MOTOR SPOOL VALVE	N/A	1

# CENTRIFUGAL PUMPS

## 3" POLY M350 MANIFOLD WET SEAL PUMPS

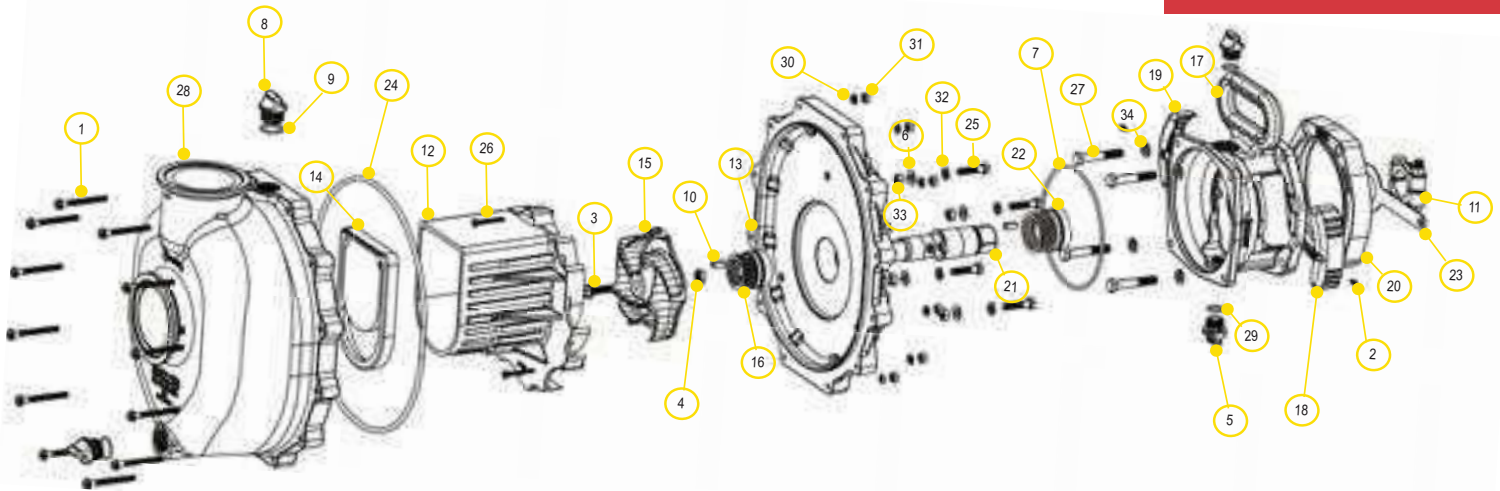

### REPLACEMENT PARTS M350 PUMPS

ITEM	PART NO	DESCRIPTION	QTY
1	12720	1/4-20 X 2 1/2" SL IND HEX WASHER HEAD SCREW	12
2	12725	#6 X 1/2" PPH SMS	2
3	12765A	5/16-24 X 1 1/8" HFS	1
4	12775A	7/16-14 HEX NUT	1
5	12777	1/2" DRAIN PLUG	2
6	12901	5/16" FLAT WASHER	8 (4 SHOWN)
7	13719	AS568A -256 O-RING, EPDM, BLACK	1
8	13777	3/4" DRAIN PLUG, MOLDED	2
9	13778	AS568A -119 O-RING, EPDM, BLACK	2
10	16901SS	1/4" SQ. X 5/8" KEY 18-8 SS	2
11	18029	SS CLAMP	1
12	35002	M350 DIFFUSER	1
13	35004	M350 REAR BRACKET	1
14	35005	3" WET SEAL POLY PUMP CHECK VALVE	1
15	35073	M350 5-VANE IMPELLER	1
16	35013E	1.125" MECHANICAL SEAL, EPDM	1
17	35201	M350 WET SEAL RESERVOIR	1
18	35246GL	LEFT SHAFT GUARD FOR M350P	1
19	35246GR	RIGHT SHAFT GUARD FOR M350P	1
20	35248	M350 ENGINE SPACER	1
21	35255A	3" WET SEAL POLY PUMP SHAFT ADAPTER FOR BEM15-100	1
22	35213E	1.375" MECHANICAL SEAL, EPDM	1
23	35901	350 PUMP SEAL SPACING TOOL	1
24	A380E	AS568 #380 EPDM O-RING	1
25	B0516138	5/16-18 X 1 3/8" HHCS	4
26	B1014150TS	#10 X 1 1/2 THREAD FORMING SCREW, 18-8 SS	3
27	BF207	3/8-16 X 2 1/4" HHCS	4
28	M35012	M350 MANIFOLD BODY	1
29	UV15163	AS568A -114 O-RING, EPDM, BLACK	2
30	V07018	1/4" LOCKWASHER	12
31	V07019	1/4"-20 S.S. HEX NUT	12
32	V10118	5/16" SS LOCKWASHER	8 (4 SHOWN)
33	V10119	5/16"-18 SS NUT	8 (4 SHOWN)

### REPLACEMENT PARTS M350 PUMPS

ITEM	PART NO	DESCRIPTION	QTY
34	V20018	3/8" Lockwasher, SS	4
35	17034	5/16-18 X 1-1/2" HHCS	1
36	35033	Z-RAIL FOR M350PH13W	1
NS	35500	BEARING PEDESTAL ASSEMBLY	1
NS	35000	REPAIR KIT REPAIR KIT(CONSIST OF ITEMS 7, 9, 10, 12, 14, 15, 16, 22, 23, 24, 26, 29)	1
KIT	HY1004B	HYDRAULIC MOTOR REPAIR KIT	1

### HYDRAULIC MOTOR DATA

U.S. GALLONS/REV.	0.0029
CUBIC INCHES/REV.	0.671
LITERS/REV.	0.0110
MAX HYDRAULIC PRESSURE	3045 PSI
MIN HYDRAULIC PRESSURE	10 PSI
INLET PORT	SAE 10 (7/8-14 UNF)
OUTLET PORT	SAE 12 (1 1/16-12UN)
MINIMUM GPM REQUIRED	7 GPM / 2400 RPM
MAXIMUM GPM REQUIRED	11.6 GPM / 4000 RPM
IDEAL GPM REQUIRED	10.5 GPM / 3600 RPM

### CONNECTION INFORMATION

INLET	NOT LABELED
OUTLET	NOT LABELED
DRAIN	SAE 6 (9/16-18 UNF)

CASE DRAIN MUST BE PLUMBED. DO NOT PLUG DRAIN PORT. IT IS RECOMMENDED THAT A MINIMUM 3/4" INLET LINE & A MINIMUM 1" OUTLET LINE BE USED. THE OUTLET PORT MUST BE CONNECTED DIRECTLY BACK TO THE HYDRAULIC FLUID RESERVOIR & NOT TO ANY VALVING, REGULATORS OR FLOW DIVERTERS. THE OUTLET PORT/RETURN LINE BACK PRESSURE MUST NOT EXCEED 250 PSI.

### SPOOL VALVE INFORMATION

REQUIRED OUTLET FLOW	MIN 9 GPM / MAX 13 GPM
REQUIRED SYSTEM PRESSURE	MIN 600 PSI / MAX 3000 PSI

# CENTRIFUGAL PUMPS

## 1½" - 2" CAST IRON PUMPS

### FEATURES

- Cast iron construction for rugged dependable service
- Stainless steel shaft sleeve to protect engine shaft
- Carbon ceramic seal with stainless steel cup and spring with FKM rubber
- Replaceable inlet and outlet flanges
- Dynamically balanced impeller
- Pump only packs complete and ready for attachment to gasoline engine
- Pedestal pump for long coupling to electric motor
- Recommendation for 5/8" shaft: 56C frame size, 3 HP, 3450 RPM & 5" max impeller for close coupling to electric motors
- Recommendation for 7/8" shaft: 145TC frame size, 3 HP, 3450 RPM & 5" max impeller for close coupling to electric motors
- Engine warranty service available at authorized dealers



**WARNING! DO NOT RUN PUMP DRY, RESTRICT OR REDUCE PORT SIZES OR DEAD HEAD PUMP**



**WARNING! DO NOT USE WITH FLAMMABLE LIQUIDS**



### 2" CAST IRON PUMP W/GAS ENGINES

PART NO	DESCRIPTION	HP	QTY	SKID QTY
200PI-3	2" CAST IRON PUMP W/3.5 HP BRIGGS & STRATTON® ENGINE	3.5	1	8
200PI6PRO	2" CAST IRON PUMP W/6.5 HP BRIGGS & STRATTON® ENGINE PRO SERIES	6.5	1	8
200PIH6	2" CAST IRON PUMP W/6.5 HP HONDA® ENGINE	5.5	1	8
200PIH5E	2" CAST IRON PUMP W/5.5 HP HONDA® ENGINE W/ ELECTRIC START	5.5	1	8

### 2" CAST IRON PUMP ONLY

PART NO	DESCRIPTION	HP	QTY	SKID QTY
200POI	2" CAST IRON PUMP ONLY W/ ¾" SHAFT SLEEVE	N/A	1	27

### 1½" CAST IRON C-FLANGE PUMPS

PART NO	DESCRIPTION	HP	QTY	SKID QTY
150POICF5/8-4.1	1½" CAST IRON C-FLANGE PUMP W/ 5/8" SHAFT SLEEVE & 4.1 IMPELLER	N/A	1	18

### 2" CAST IRON C-FLANGE PUMPS

PART NO	DESCRIPTION	HP	QTY	SKID QTY
200POICF5/8	2" CAST IRON C-FLANGE PUMP W/ 5/8" SHAFT SLEEVE	N/A	1	18
200POICF7/8	2" CAST IRON C-FLANGE PUMP W/ 7/8" SHAFT SLEEVE	N/A	1	18

### 2" CAST IRON BEARING PEDESTAL

PART NO	DESCRIPTION	HP	QTY	SKID QTY
200PBI	2" CAST IRON BEARING PEDESTAL W/ ¾" STRAIGHT SHAFT	N/A	1	18

# CENTRIFUGAL PUMPS

1½" - 2" CAST IRON PUMPS

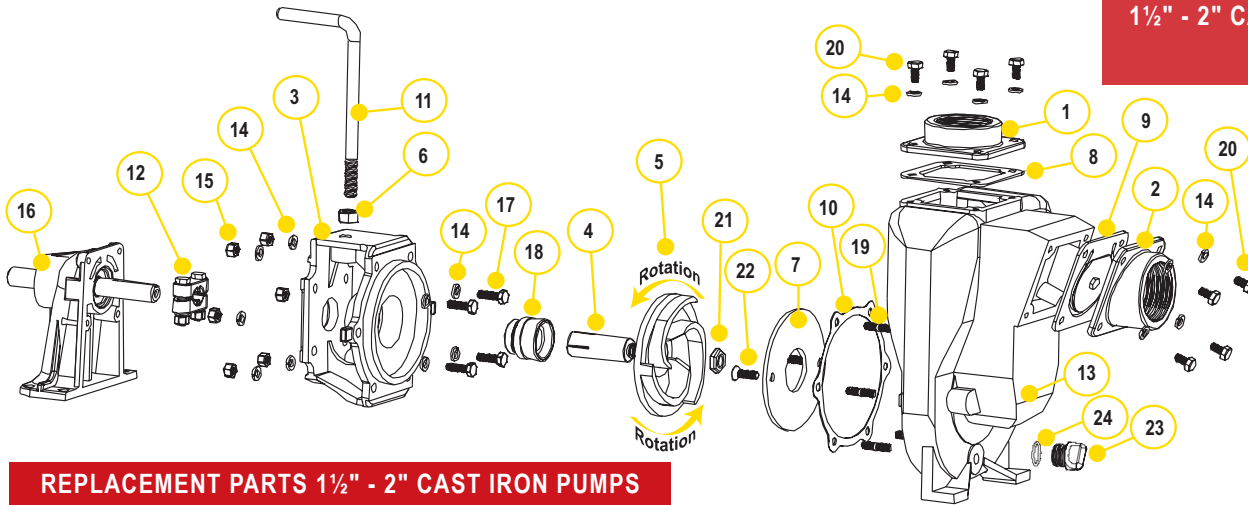

## REPLACEMENT PARTS 1½" - 2" CAST IRON PUMPS

ITEM	PART NO	DESCRIPTION	QTY
1	17001	1½" NPT OUTLET FLANGE	1
1	17000	2" NPT OUTLET FLANGE	1
2	17003	1½" NPT INLET FLANGE	1
2	17002	2" NPT INLET FLANGE	1
3	17004	ADAPTER FOR GAS ENGINE	1
3	17046	C-FACE ADAPTER	1
4	17005	5/8" SLEEVE DRIVE FOR ELECTRIC MOTOR	1
4*	17006	¾" SLEEVE DRIVE	1
4	17007	7/8" SLEEVE DRIVE FOR ELECTRIC MOTOR	1
5*	17008	5" IMPELLER	1
5	17008-4.1	4.1" TRIMMED IMPELLER	1
6	17010	½" HEX NUT	1
7*	17011	WEAR PLATE	1
8	17013	EPDM GASKET	1
9	17016	CHECK VALVE ASSEMBLY	1
10*	17018	GASKET ADAPTER	1
11	15022	HANDLE	1
12	17023	5/8" CLAMP FOR ¾" SHAFT ASSEMBLY (OLD STYLE)	1
12	17123	5/8" CLAMP FOR ¾" SHAFT ASSEMBLY (KEYED)	1
12	17024	7/8" CLAMP FOR SHAFT ASSEMBLY	1
13	17026	PUMP HOUSING	1
14	V10118	5/16" LOCK WASHER	18
15	V10119	5/16" - 18 SS HEX NUT	6
N/S	12883B	BEARINGS	1
16	12882A	COMPLETE PEDESTAL ASSEMBLY	2
17	17040	5/16" - 24 X 1.00" CAP SCREW	1
18	17028	EPDM SEAL ASSEMBLY	4
18*	17035	FKM SEAL ASSEMBLY	1
18	17035SD	SEVERE DUTY SEAL	1
19	17042	STUD	6
20	17019	5/16"-18 X ¾" CAP SCREW	8
21	17009B	5/8" IMPELLER NUT	1
22	17130	5/16-18 X 1.00" FHSCS, 18-8 SS	2
23	12777	½" PLUG	1
24	UV15163	O-RING	1
N/S	17033	Z RAILS (PAIR)	1
N/S	17100	REPAIR KIT (CONSISTS OF ITEMS 4*, 5*, 7,10,18*)	1

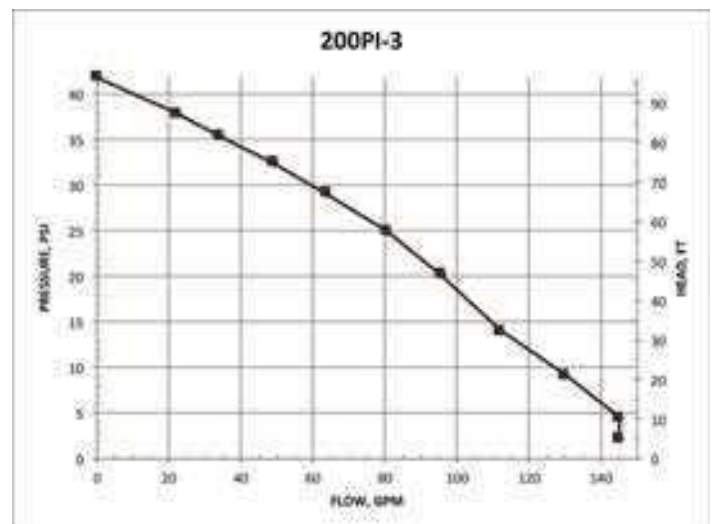

# CENTRIFUGAL PUMPS

## 2" CAST IRON WET SEAL PUMPS

### FEATURES

- Cast iron construction for rugged dependable service
- Stainless steel hardware
- FKM double seal contained in glycol reservoir
- Replaceable inlet and outlet flanges
- Dynamically balanced impeller
- Pump only packs complete and ready for attachment to gasoline engine
- Pedestal pump for long coupling to electric motor
- Due to weight and size of pumps, Banjo ships these by truck only.



### 2" CAST IRON WET SEAL PUMPS W/GAS ENGINES

PART NO	DESCRIPTION	HP	QTY	SKID QTY
201PIH6W	2" CAST IRON WET SEAL PUMP W/6.5 HP HONDA® ENGINE	5.5	1	8



### 2" CAST IRON WET SEAL PUMP ONLY

PART NO	DESCRIPTION	HP	QTY	SKID QTY
201POIW	2" CAST IRON WET SEAL PUMP ONLY	N/A	1	18



WARNING! DO NOT RUN PUMP DRY, RESTRICT OR REDUCE PORT SIZES OR DEAD HEAD PUMP



WARNING! DO NOT USE WITH FLAMMABLE LIQUIDS



### 2" CAST IRON WET SEAL PUMP BEARING PEDESTAL

PART NO	DESCRIPTION	HP	QTY	SKID QTY
201PBIW	2" CAST IRON WET SEAL PUMP WITH BEARING PEDESTAL	N/A	1	18

# CENTRIFUGAL PUMPS

## 2" CAST IRON WET SEAL PUMPS

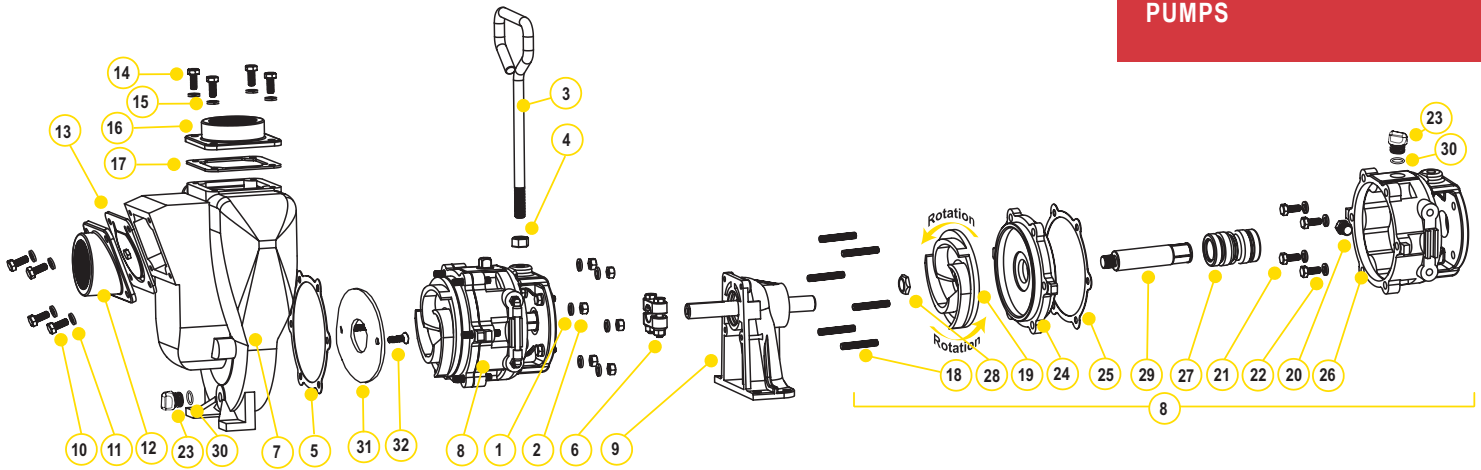

### REPLACEMENT PARTS 2" CAST IRON PUMPS

ITEM	PART NO	DESCRIPTION	QTY
1	V10118	5/16" LOCK WASHER	6
2	V10119	5/16" -18 HEX NUT	6
3	15022	HANDLE	1
4	17010	1/2" HEX NUT	1
5	17018	GASKET ADAPTER	1
6	17123	5/8" CLAMP, 3/4" SHAFT ASSEMBLY KEYED	1
7	17226	PUMP HOUSING	1
8	N/A	WET SEAL ASSEMBLY	1
9	12882A	BEARING PEDESTAL	1
10	17019	5/16"-18 X 3/4" HHCS	4
11	V10118	5/16" LOCK WASHER	4
12	17002	2" NPT INLET FLANGE	1
13	17016	EPDM CHECK VALVE GASKET ASSEMBLY	1
14	17019	5/16" -18 X 3/4" HHCS	4
15	V10118	5/16" LOCK WASHER	4
16	17000	2" NPT OUTLET FLANGE	1
17	17013	EPDM OUTLET GASKET	1
18	17242	HOUSING STUD	6
19	17208	IMPELLER	1
20	17032	PIPE PLUG	1
21	17019	5/16"-18 X 3/4" CAP SCREW	4
22	V10118	5/16" LOCK WASHER	4
23	12777	1/2" PLUG	2
24	17202	COVER PLATE	1
25	17018	GASKET ADAPTER	1
26	17201A	RESERVOIR	1
27	17235	FKM MECHANICAL SEAL ASSEMBLY	1
28	17009B	5/8" IMPELLER NUT	1
29	17206A	ADAPTER SHAFT	1
30	UV15163	O-RING	2
31	17011	Wear Plate	1
32	17130	5/16-18 X 1.00" FHSCS, 18-8 SS	1

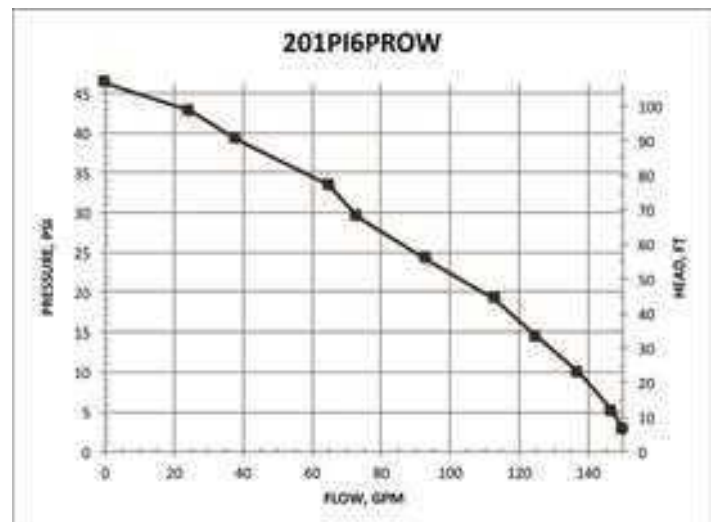

# CENTRIFUGAL PUMPS

## 2" CAST IRON PUMPS WITH ELECTRIC MOTORS

### FEATURES

- Cast iron construction for rugged dependable service
- Stainless steel shaft sleeve to protect engine shaft
- Carbon ceramic seal with stainless steel cup and spring with FKM rubber
- Replaceable inlet and outlet flanges
- Dynamically balanced impeller
- Pump only packs complete and ready for attachment to gasoline engine
- Due to weight and size of pumps, Banjo ships these by truck only.
- Motor warranty service available at authorized dealers
- Motor features include pressure cast aluminum end plates with ribbed design for rigidity, heavy gauge steel frame, 230 volt, with inverter spike resistance magnet wire



### 2" CAST IRON PUMPS W/ELECTRIC MOTORS

PART NO	DESCRIPTION	HP	QTY	SKID QTY
234PIE5	2" CAST IRON PUMP W/5 HP THREE PHASE ELECTRIC MOTOR	5	1	3
234PIE51	2" CAST IRON PUMP W/5 HP SINGLE PHASE ELECTRIC MOTOR	5	1	3

### 2" CAST IRON PUMP ONLY

PART NO	DESCRIPTION	HP	QTY	SKID QTY
234POI	2" CAST IRON PUMP ONLY W 184TC FRAME ADAPTER	N/A	1	18



WARNING! DO NOT RUN PUMP DRY, RESTRICT OR REDUCE PORT SIZES OR DEAD HEAD PUMP



WARNING! DO NOT USE WITH FLAMMABLE LIQUIDS

# CENTRIFUGAL PUMPS

2" CAST IRON PUMPS WITH ELECTRIC MOTORS

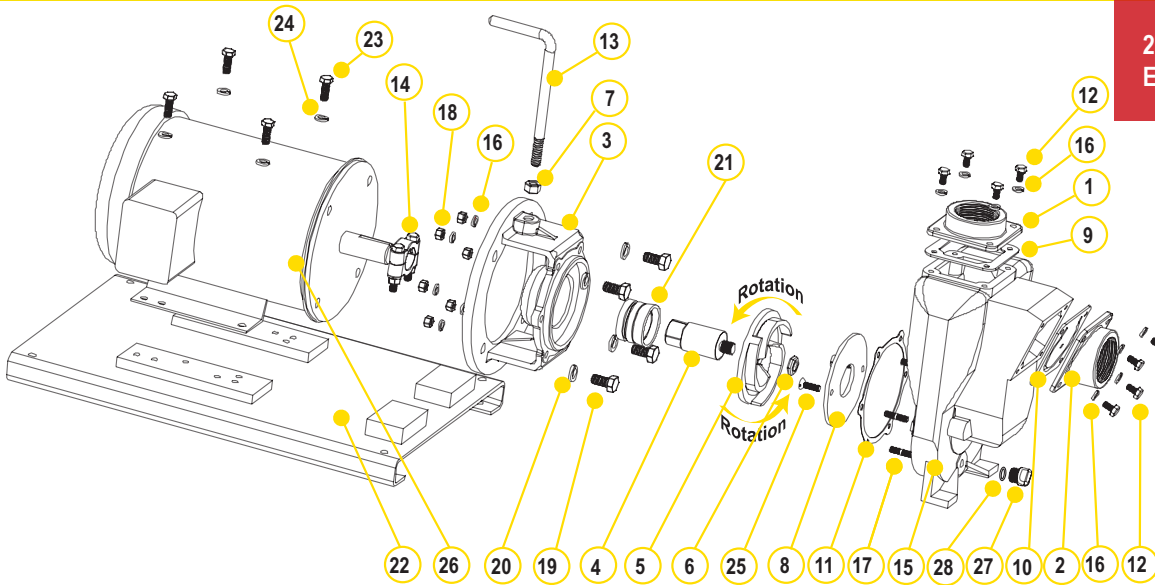

## REPLACEMENT PARTS 2" CAST IRON PUMPS

ITEM	PART NO	DESCRIPTION	QTY
1	17000	2" NPT OUTLET FLANGE	1
2	17002	2" NPT INLET FLANGE	1
3	17046	C-FACE ADAPTER (234PIE3)	1
3	17446	C-FACE ADAPTER	1
4	17007	IMPELLER SHAFT (234PIE3)	1
4	17406	IMPELLER SHAFT	1
5	17008	IMPELLER (234PIE3)	1
5	17408	IMPELLER	1
6	17009B	5/8" IMPELLER NUT	1
7	17010	1/2" HEX NUT	1
8	17011	WEAR PLATE	1
9	17013	OUTLET GASKET	1
10	17016	GASKET & CHECK VALVE	1
11	17018	GASKET ADAPTER	1
12	17019	BOLT	8
13	15022	HANDLE	1
14	17024	CLAMP ASSEMBLY W/KEY (234PIE3)	1
14	18129	CLAMP ASSEMBLY W/KEY	1
15	17026	PUMP HOUSING	1
16	V10118	5/16" LOCK WASHER	20
17	17042	HOUSING STUD	6
18	V10119	HEX NUT	8
19	N/A	BOLT	4
20	N/A	WASHER	4
21	17035	SEAL ASSEMBLY (234PIE3)	1
21	18025	SEAL ASSEMBLY	1
22	17701	BASE PLATE ASSEMBLY	1
23	17704	BOLT	4
24	V20018	3/8" LOCK WASHER	4
25	17130	5/16-18 X 1.00" FHSCS, 18-8 SS	2
26	N/A	ELECTRIC MOTOR	1
27	12777	1/2" PLUG	1
28	UV15163	O-RING FOR DRAIN PLUG	1

234 SERIES PUMP

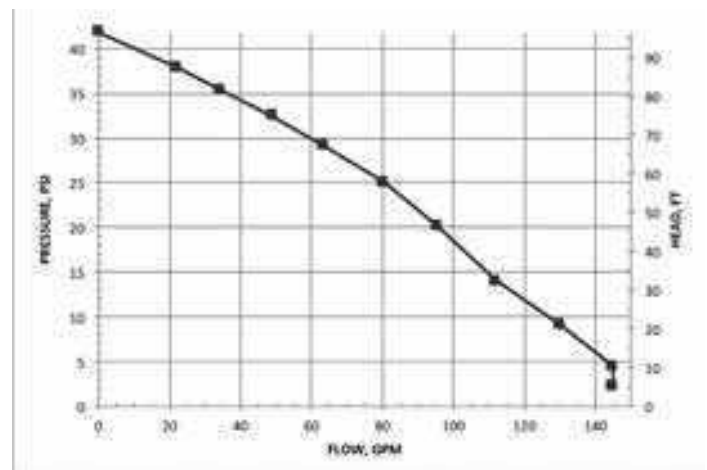

# CENTRIFUGAL PUMPS

## 2" CAST IRON PUMPS WITH HYDRAULIC MOTORS

### FEATURES

- Cast iron construction for rugged dependable service
- Stainless steel hardware
- Replaceable inlet and outlet flanges
- Dynamically balanced impeller
- Hydraulic fluid capacity is minimum 6 gallons and maximum 10 gallons
- Open or closed system
- 12 HP motor
- Recommendation to use the motor spool control valve or a suitable equivalent. The lack of such a valve in this circuit may cause failure to the hydraulic motor and will void warranty.



### 2" CAST IRON PUMPS WITH HYDRAULIC MOTOR

PART NO	DESCRIPTION	HP	QTY	SKID QTY
200PIHY	2" CAST IRON PUMP ONLY WITH HYDRAULIC MOTOR	12	1	18



**WARNING! DO NOT RUN PUMP DRY, RESTRICT OR REDUCE PORT SIZES OR DEAD HEAD PUMP**



**WARNING! DO NOT USE WITH FLAMMABLE LIQUIDS**

### SPOOL VALVE ASSEMBLY DIAGRAM

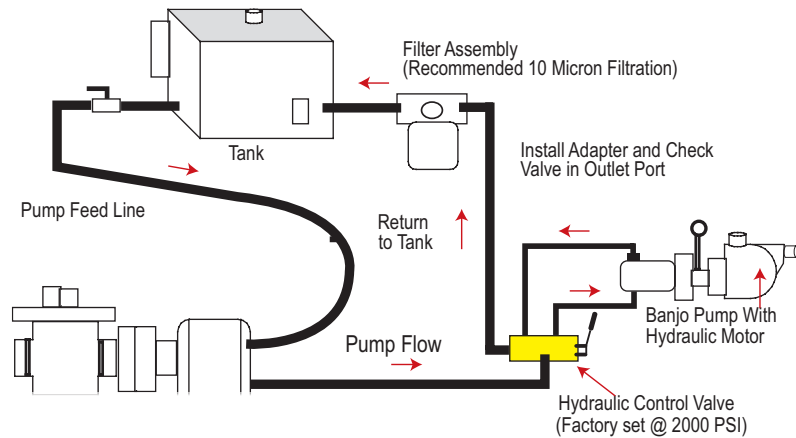

### HYDRAULIC MOTOR SPOOL VALVE

PART NO	DESCRIPTION	HP	QTY
HSV1000	HYDRAULIC MOTOR SPOOL VALVE	N/A	1

# CENTRIFUGAL PUMPS

2" CAST IRON PUMPS WITH HYDRAULIC MOTORS

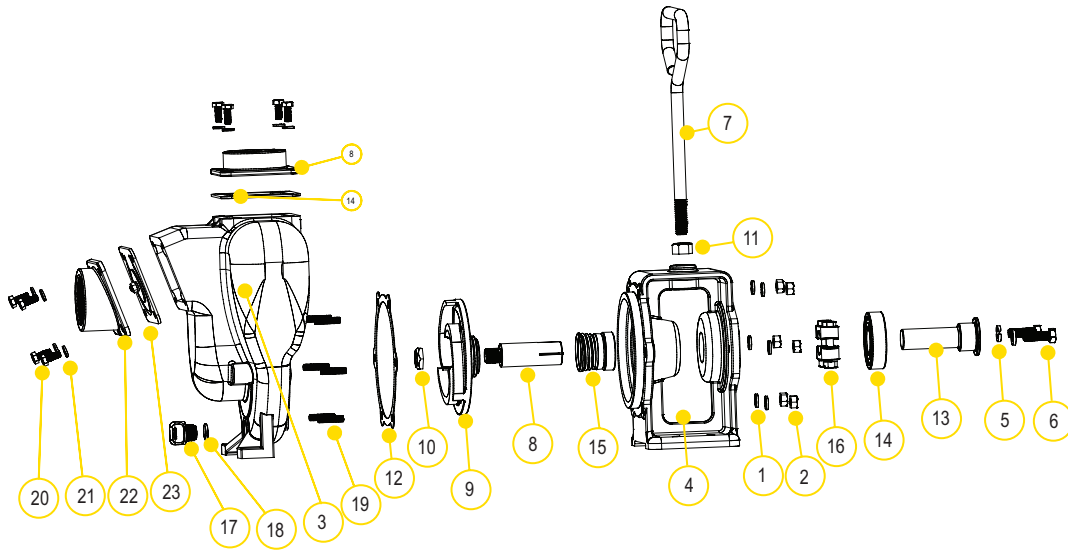

## REPLACEMENT PARTS 2" CAST IRON PUMPS

ITEM	PART NO	DESCRIPTION	QTY
1	V10118	5/16" SPLIT LOCK WASHER	6
2	V10119	5/16"-18 HEX NUT	6
3	17026	PUMP HOUSING	1
4	17049A	HYDRAULIC ADAPTER	1
5	V20018	3/8" LOCK WASHER	2
6	18010SS	3/8"-16 X 1.25" HHCS	2
7	15022	HANDLE	1
8	17007	7/8" SLEEVE DRIVE FOR HYDRAULIC MOTOR	1
9	17008	5" IMPELLER	1
10	17009B	5/8" IMPELLER NUT	1
11	17010	1/2" HEX NUT - 13UNF-RH	1
12	17018	GASKET ADAPTER	1
13	17055A	HYDRAULIC ADAPTER SHAFT	1
14	17056	SKF 6206-2RS1 BEARING	1
15	17035	FKM SEAL ASSEMBLY	1
16	17024	7/8" CLAMP, NO KEY	1
17	12777	1/2" PLUG	1
18	UV15163	O-RING	1

-HY1013 MOTOR ONLY

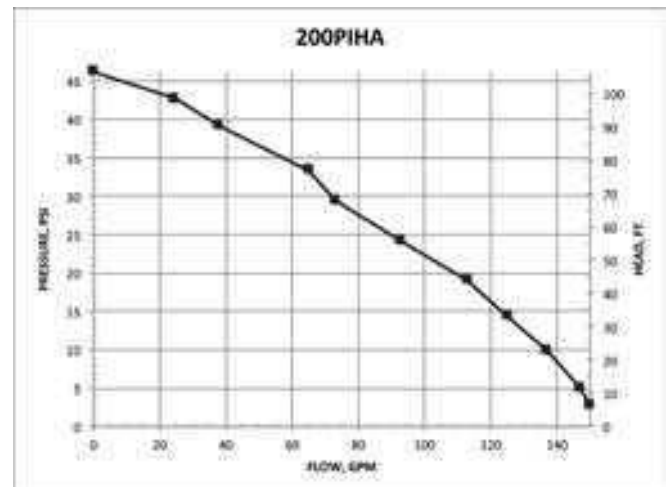

# CENTRIFUGAL PUMPS

## 2" 222 SERIES CAST IRON PUMPS

### FEATURES

- Cast iron construction for rugged dependable service
- Carbon ceramic seal with stainless steel cup and spring with FKM rubber
- Replaceable inlet and outlet flanges
- Dynamically balanced impeller
- Heavy duty slinger seal on motor shaft
- Large weep holes between pump end and engine
- Pump only packs complete and ready for attachment to gasoline engine
- Pedestal pump for long coupling to electric motor
- Recommendation for 3/4" shaft: 5 HP, 3600 RPM
- Due to weight and size of pumps, Banjo ships these by truck only.
- Engine warranty service available at authorized dealers



WARNING! DO NOT RUN PUMP DRY, RESTRICT OR REDUCE PORT SIZES OR DEAD HEAD PUMP



WARNING! DO NOT USE WITH FLAMMABLE LIQUIDS



POWERED by  
**HONDA**

### 222 SERIES CAST IRON PUMPS W/GAS ENGINES

PART NO	DESCRIPTION	HP	QTY	SKID QTY
222PIH6	2" CAST IRON PUMP W/6.5 HP HONDA® ENGINE	6.5	1	8
222PIH5E	2" CAST IRON PUMP W/5.5 HP HONDA® ENGINE W/ ELECTRIC START	5.5	1	8
222PI6PRO	2" CAST IRON PUMP W/6.5 HP BRIGGS & STRATTON® ENGINE PRO SERIES	6.5	1	8



### 222 SERIES CAST IRON PUMP ONLYS

PART NO	DESCRIPTION	HP	QTY	SKID QTY
222POI	2" CAST IRON PUMP ONLY W/ FULL IMPELLER	N/A	1	18



### 222 SERIES CAST IRON BEARING PEDESTAL

PART NO	DESCRIPTION	HP	QTY	SKID QTY
222PBI	2" CAST IRON BEARING PEDESTAL W/ 3/4" STRAIGHT KEYS SHAFT	N/A	1	18

# CENTRIFUGAL PUMPS

## 2" 222 SERIES CAST IRON PUMPS

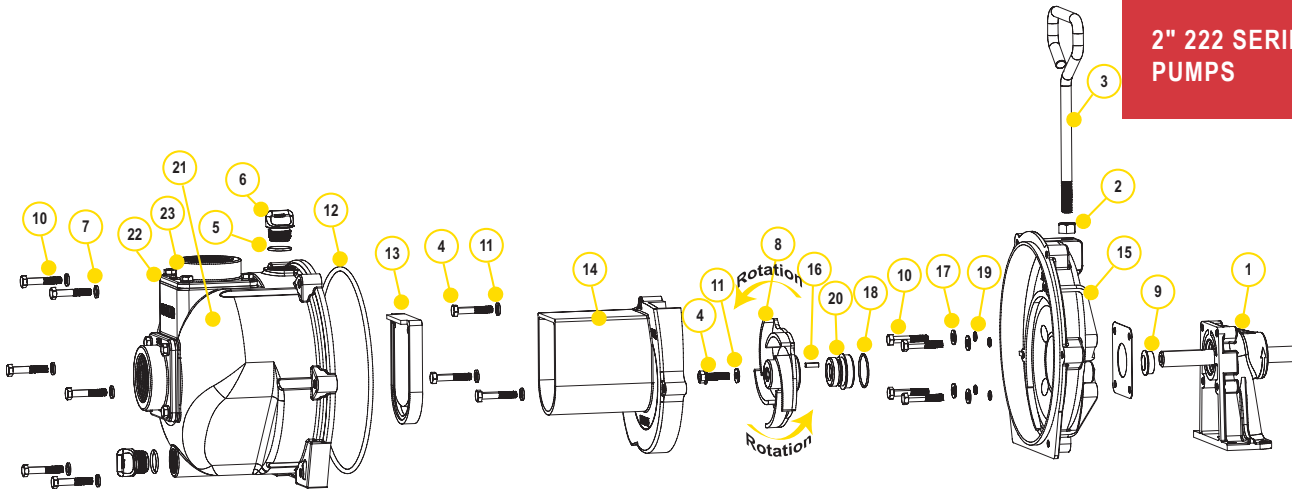

### REPLACEMENT PARTS 2" CAST IRON PUMPS

ITEM	PART NO	DESCRIPTION	QTY
1	12882A	BEARING PEDESTAL ASSEMBLY	1
1	12600B	HYDRAULIC PEDESTAL ASSEMBLY	1
2	17010	1/2" JAM NUT	1
3	15022	HANDLE	1
4	12765A	5/16" - 24 X 1.12 IMPELLER BOLT	1
5	13778	O-RING	2
6	13777	3/4" PLUG	2
7	V10118	5/16" LOCK WASHER	9
8	15772	5 VANE IMPELLER	1
9	12716	PUMP SLINGER	1
10	12715A	5/16" - 24 X 1.75 HHCS	13
11	A204	O-RING	1
12	12719A	BODY O-RING	1
13	12705	CHECK VALVE	1
14	15702	VOLUTE	1
15	15703	REAR BRACKET	1
16	12902A	3/16" SQ X 5/8" KEY	1
17	12901	5/16" FLAT WASHER	4
18	12710	O-RING	1
19	12717	O-RING	4
20	12713V	SEAL ASSEMBLY	1
20	N/A	SEVERE DUTY SEAL	1
21	15712	BODY	1
22	17013	FLANGE GASKET	2
23	17000	2" NPT THREADED FLANGE	2
24	17019	5/16" - 18 X 0.75 HHCS	8
25	V10118	5/16" LOCK WASHER	8
N/S	12099	7/16"-14 X 1.25" HHCS	1
N/S	15751	BRACKET SHIM	1
N/S	15752	IMPELLER SHIM	1
N/S	17033	Z-RAILS	1 PAIR
N/S	N/A	5/16" - 18 X 1 3/4" ZINC PLATED	4
N/S	V10119	5/16" -18 HEX NUT	4
N/S	V10118	5/16" LOCK WASHER	4
N/S	15000	REPAIR KIT (ITEMS 5, 8, 11-12, 18-20, 12099, 15751 & 15752)	1
N/S	15000V	FKM REPAIR KIT	1
N/S	15999	SEAL KIT (ITEMS 5, 11-12, 18-20, 12099, 15751 & 15752)	1
N/S	15999V	FKM SEAL KIT	1

### KITS 222 CAST IRON PUMPS

PART NO	EPDM REPAIR KIT NO	FKM REPAIR KIT NO	EPDM SEAL KIT NO	FKM SEAL KIT NO
222PIH6	15000	15000V	15999	15999V
222PIH5E	15000	15000V	15999	15999V
222PI6PRO	15000	15000V	15999	15999V
222POI	15000	15000V	15999	15999V
222PBI	15000	15000V	15999	15999V

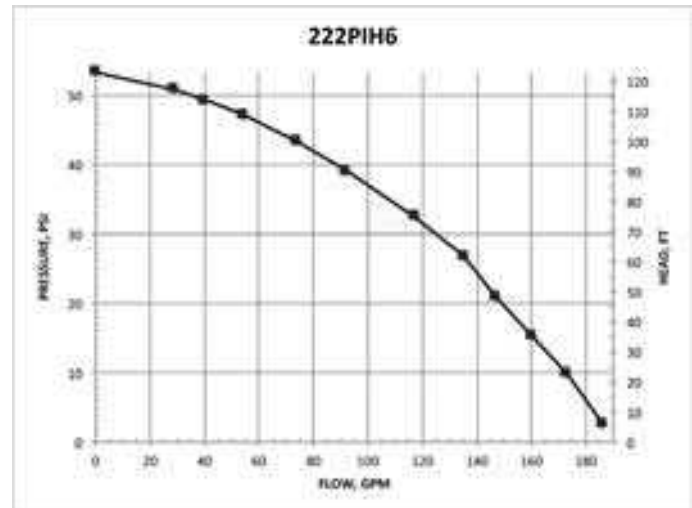

# CENTRIFUGAL PUMPS

## 2" 222 SERIES CAST IRON PUMPS WITH ELECTRIC MOTORS

### FEATURES

- Cast iron construction for rugged dependable service
- Carbon ceramic seal with stainless steel cup and spring with FKM rubber
- Replaceable inlet and outlet flanges
- Dynamically balanced impeller
- Heavy duty slinger seal on motor shaft
- Large weep holes between pump end and engine
- Motor features include pressure cast aluminum end plates with ribbed design for rigidity, heavy gauge steel frame, 230 volt, with inverter spike resistance magnet wire
- Due to weight and size of pumps, Banjo ships these by truck only.



### 222 SERIES CAST IRON PUMPS W/ELECTRIC MOTORS

PART NO	DESCRIPTION	HP	QTY	SKID QTY
222PIE5	2" CAST IRON PUMP W/5 HP THREE PHASE ELECTRIC MOTOR	5	1	3
222PIE51	2" CAST IRON PUMP W/5 HP SINGLE PHASE ELECTRIC MOTOR	5	1	3



WARNING! DO NOT RUN PUMP DRY, RESTRICT OR REDUCE PORT SIZES OR DEAD HEAD PUMP



WARNING! DO NOT USE WITH FLAMMABLE LIQUIDS

# CENTRIFUGAL PUMPS

**2" 222 SERIES CAST IRON PUMPS WITH ELECTRIC MOTORS**

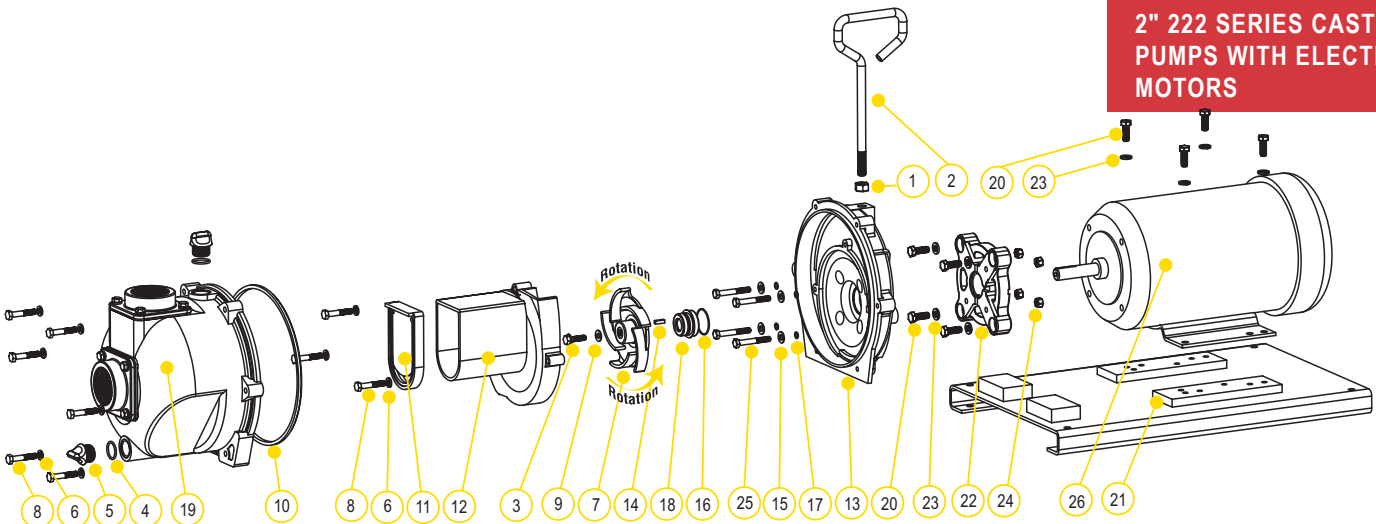

## REPLACEMENT PARTS 222 SERIES CAST IRON PUMPS

ITEM	PART NO	DESCRIPTION	QTY
1	17010	1/2" JAM NUT	1
2	15022	HANDLE	1
3	12765A	5/16" - 24 X 1.12 IMPELLER BOLT	1
4	13778	O-RING	2
5	13777	3/4" PLUG	2
6	V10118	5/16" LOCK WASHER	9
7	15772	5 VANE IMPELLER	1
8	12715A	5/16" - 24 X 1.75 HHCS	13
9	A204	O-RING	1
10	12719A	BODY O-RING	1
11	12705	CHECK VALVE	1
12	15702	VOLUTE	1
13	15703	REAR BRACKET	1
14	12902A	3/16" SQ. X 5/8" KEY	1
15	12901	5/16" FLAT WASHER	1
16	12710	O-RING	4
17	12717	O-RING	1
18	12713V	SEAL ASSEMBLY	4
18	N/A	SEVERE DUTY SEAL	1
19	15712	BODY	1
20	17704	3/16" - 16 X 1.25 HHCS BOLT	8
21	17701	C-FACED BASE PLATE	1
22	12046	56C ADAPTER	1
23	V20018	3/8" LOCK WASHER	8
24	V20019	3/8" 16 SS HEX NUT	4
25	N/A	5/16" - 18 X 2 1/4" HHCS BOLT	4
26	BEM5-182CZ	5 HP 3450 RPM THREE PHASE MOTOR	1
26	BEM51-182CZ	5 HP 3450 RPM SINGLE PHASE MOTOR	1
N/S	12099	7/16"-14 X 1.25" HHCS	1
N/S	15751	BRACKET SHIM	1
N/S	15752	IMPELLER SHIM	1
N/S	12756	ADAPTER KIT (ITEMS 14, 20, 22, 23, 12052, 12053, 15751, 15752, 17029)	1
N/S	15000	REPAIR KIT (ITEMS 4,7,9-11,14,16-18,12099,15751&15752)	1
N/S	15000V	FKM REPAIR KIT	1
N/S	15999	SEAL KIT (ITEMS 4, 9-11, 14,16-18,12099,15751&15752)	1
N/S	15999V	FKM SEAL KIT	1

## KITS 222 CAST IRON PUMPS

PART NO	EPDM REPAIR KIT NO	FKM REPAIR KIT NO	EPDM SEAL KIT NO	ADAPTER KIT NO
222PIE5	15000	15000V	15999	12756
222PIE51	15000	15000V	15999	12756



# CENTRIFUGAL PUMPS

## 3" CAST IRON PUMPS

### FEATURES

- Cast iron construction for rugged dependable service
- Stainless steel shaft sleeve to protect engine shaft
- Carbon ceramic seal with stainless steel cup and spring with FKM rubber
- Replaceable inlet and outlet flanges
- Dynamically balanced impeller
- Pump only packs complete and ready for attachment to gasoline engine
- Bearing pedestal pump for long coupling to electric motor
- Recommendation for 1" shaft: 184TC frame size, 7½ HP, 3450 RPM for close coupling to electric motors
- Engine warranty service available at authorized dealers
- Due to weight and size of pumps, Banjo ships these by truck only.



### 3" CAST IRON PUMP W/GAS ENGINES

PART NO	DESCRIPTION	HP	QTY	SKID QTY
300PIH13	3" CAST IRON PUMP W/13 HP HONDA® ENGINE W/ELECTRIC START & PULL ROPE	13	1	6



### 3" CAST IRON PUMP ONLY

PART NO	DESCRIPTION	HP	QTY	SKID QTY
300POI	3" CAST IRON PUMP ONLY W/ 1" SHAFT SLEEVE	N/A	1	8
300POICF	3" CAST IRON PUMP WITH C-FLANGE	N/A	1	8
300POICF55	3" CAST IRON PUMP WITH C-FACE W/5 ½" IMPELLER	N/A	1	8

CF PUMPS WILL FIT A 184TC FRAME SIZE



WARNING! DO NOT RUN PUMP DRY, RESTRICT OR REDUCE PORT SIZES OR DEAD HEAD PUMP



WARNING! DO NOT USE WITH FLAMMABLE LIQUIDS



### 3" CAST IRON BEARING PEDESTAL

PART NO	DESCRIPTION	HP	QTY	SKID QTY
300PBI	3" CAST IRON BEARING PEDESTAL W/ 1" STRAIGHT SHAFT	N/A	1	8

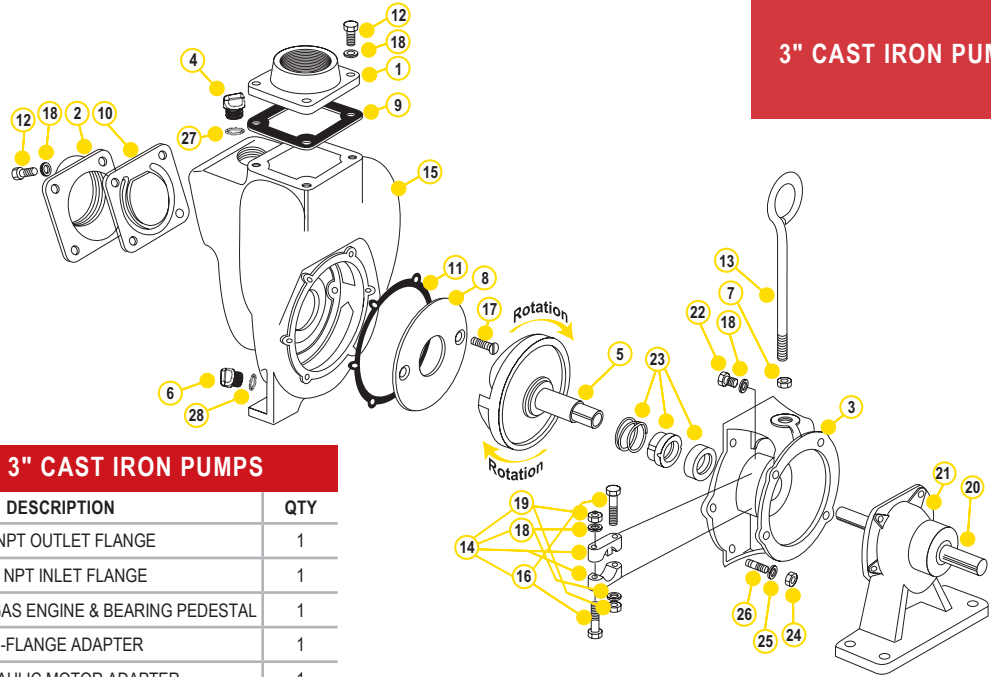

### REPLACEMENT PARTS 3" CAST IRON PUMPS

ITEM	PART NO	DESCRIPTION	QTY
1	18008	3" NPT OUTLET FLANGE	1
2	18012	3" NPT INLET FLANGE	1
3	18026	ADAPTER FOR GAS ENGINE & BEARING PEDESTAL	1
3	18048	C-FLANGE ADAPTER	1
3	18049	HYDRAULIC MOTOR ADAPTER	1
N/S	18055	HYDRAULIC ADAPTER SHAFT	1
4	13777	3/4" PLUG	1
5*	18023SS	1" IMPELLER & DRIVE SHAFT FOR GAS ENGINE	1
5	18023-1.125SS	1 1/2" IMPELLER & DRIVE SHAFT FOR ELECTRIC MOTOR	1
6	12777	1/2" PLUG	1
7	18034	5/8" SS JAM NUT	1
8	18004	WEAR PLATE	1
9	18009	EPDM OUTLET GASKET	1
10	18013	GASKET CHECK VALVE ASSEMBLY	1
11	18021	ADAPTER GASKET	1
12	18010SS	3/8" - 16 X 1 1/8" SS CAP SCREW HXHD	8
13	18033	HANDLE	1
14	18029	CLAMP ASSEMBLY (OLD STYLE)	1
14	18129	CLAMP ASSEMBLY (NEW STYLE)	1
15	18001	PUMP HOUSING	1
16	N/A	3/8" -24 X 2 1/4" BOLT	2
17	18106	WEAR PLATE FLAT HEAD SCREW	2
18	V20018	3/8" LOCK WASHER	8
19	N/A	3/8" X 24 SS HEX NUT	2
20	18504	1" SHAFT	1
21	18500	BEARING PEDESTAL	1
N/S	18502	BEARING SKF 66306-2RS1/C3	2
22	17704	BOLT	4
23*	18025	FKM SEAL ASSEMBLY	1
23	18025SD	SEVERE DUTY SEAL	1
24	V20019	3/8" 16 SS HEX NUT	6
25	V20018	3/8" SS LOCK WASHER	6
26	18218	3/8" -16 X 24 X 2 1/8" SS STUD	6
27	13778	O-RING	1
28	UV15163	O-RING	1
N/S	18035	Z-RAIL MOUNTING BRACKET (PAIR)	1
N/S	18100	REPAIR KIT (CONSIST OF ITEMS 5*, 8,11,17, 23*)	1

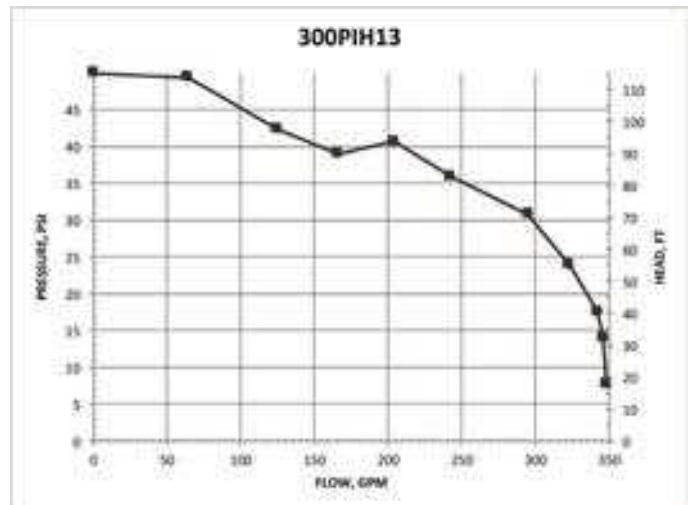

# CENTRIFUGAL PUMPS

## 3" CAST IRON WET SEAL PUMPS

### FEATURES

- Cast iron construction for rugged dependable service
- Run dry capability
- Stainless steel hardware
- Double seal contained in ethylene glycol reservoir
- Replaceable inlet and outlet flanges
- Dynamically balanced impeller
- Pump only packs complete and ready for attachment to gasoline engine
- Pedestal pump for long coupling to electric motor
- Due to weight and size of pumps, Banjo ships these by truck only.



### 3" CAST IRON WET SEAL PUMPS W/GAS ENGINES

PART NO	DESCRIPTION	HP	QTY	SKID QTY
301PIH13W	3" CAST IRON WET SEAL PUMP W/13 HP HONDA® ENGINE W/ ELECTRIC START & PULL ROPE	13	1	6



**WARNING! DO NOT USE WITH FLAMMABLE LIQUIDS**



### 3" CAST IRON WET SEAL PUMP ONLY

PART NO	DESCRIPTION	HP	QTY	SKID QTY
301POIW	3" CAST IRON WET SEAL PUMP ONLY	N/A	1	8



### 3" CAST IRON WET SEAL PUMP BEARING PEDESTAL

PART NO	DESCRIPTION	HP	QTY	SKID QTY
301PBIW	3" CAST IRON WET SEAL PUMP WITH BEARING PEDESTAL	N/A	1	8

# CENTRIFUGAL PUMPS

## 3" CAST IRON WET SEAL PUMPS

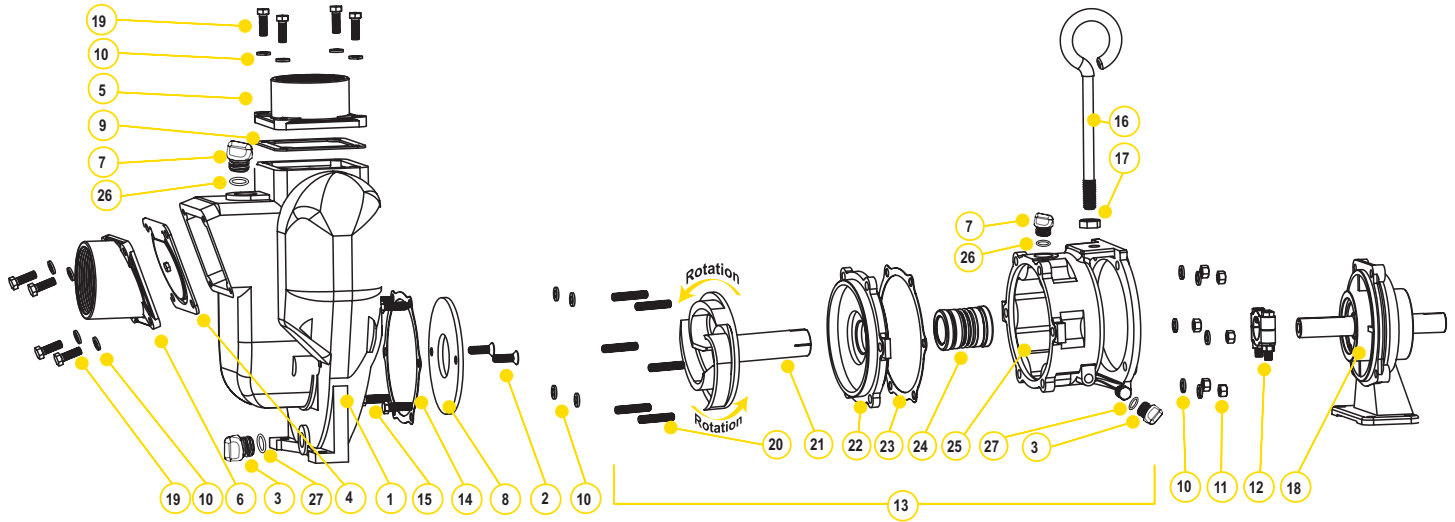

### REPLACEMENT PARTS 3" CAST IRON PUMPS

ITEM	PART NO	DESCRIPTION	QTY
1	18001	PUMP HOUSING	1
2	18106	FLAT HEAD SOCKET CAP SCREW	2
3	12777	1/2" PLUG	2
4	18013	INLET/CHECK EPDM GASKET	1
5	18008	3" NPT OUTLET FLANGE	1
6	18012	3" NPT INLET FLANGE	1
7	13777	3/4" PLUG	2
8	18004	WEAR PLATE	1
9	18009	EPDM OUTLET GASKET	1
10	V20018	3/8" LOCK WASHER	18
11	V20019	3/8" 16 SS HEX NUT	6
12	18129	CLAMP ASSEMBLY KEYED	1
13	18200A	WET SEAL ASSEMBLY	1
14	18021	ADAPTER GASKET	1
15	17704	3/8" -16 X 1 1/4" HHCS	4
16	18033	HANDLE	1
17	18034	5/8" -11 JAM NUT	1
18	18500	BEARING PEDESTAL	1
19	18010SS	3/8" - 16 X 1 1/8" HHCS	8
20	18218	3/8" -16 X 24 X 2 1/8" SS STUD	6
21	18206	IMPELLER	1
22	18202A	COVER PLATE	1
23	18021	ADAPTER GASKET	1
24	15035E	EPDM MECHANICAL SEAL ASSEMBLY	1
25	18203A	WET SEAL RESERVOIR	1
26	13778	O-RING	2
27	UV15163	O-RING	2

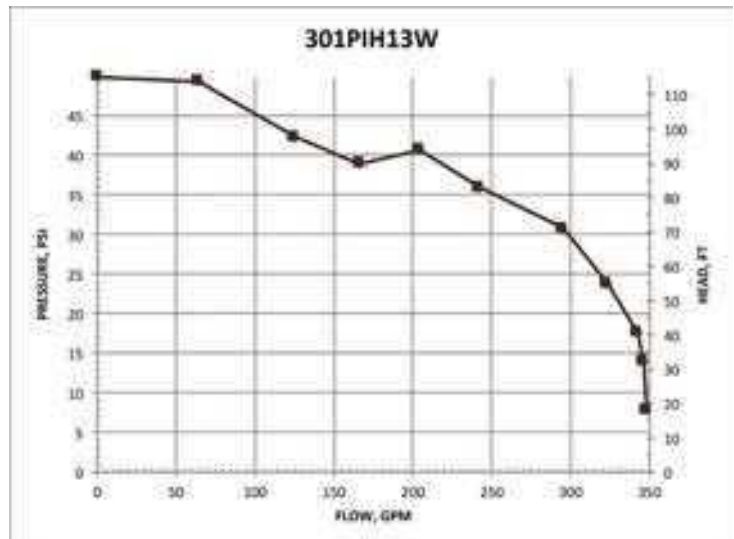

# CENTRIFUGAL PUMPS

## 3" CAST IRON PUMPS WITH HYDRAULIC MOTORS

### FEATURES

- Cast iron construction for rugged dependable service
- Stainless steel hardware
- Replaceable inlet and outlet flanges
- Dynamically balanced impeller
- Hydraulic fluid capacity is minimum 9 gallons and maximum 13 gallons
- Open or closed system
- 21 HP motor
- Recommendation to use the motor spool control valve or a suitable equivalent. The lack of such a valve in this circuit may cause failure to the hydraulic motor and will void warranty.



### 3" CAST IRON PUMPS W/ HYDRAULIC MOTORS

PART NO	DESCRIPTION	HP	QTY	SKID QTY
300PIHY	3" CAST IRON PUMP W/ 21 HP HYDRAULIC MOTOR	21	1	8



**WARNING! DO NOT RUN PUMP DRY, RESTRICT OR REDUCE PORT SIZES OR DEAD HEAD PUMP**



**WARNING! DO NOT USE WITH FLAMMABLE LIQUIDS**

### SPOOL VALVE ASSEMBLY DIAGRAM

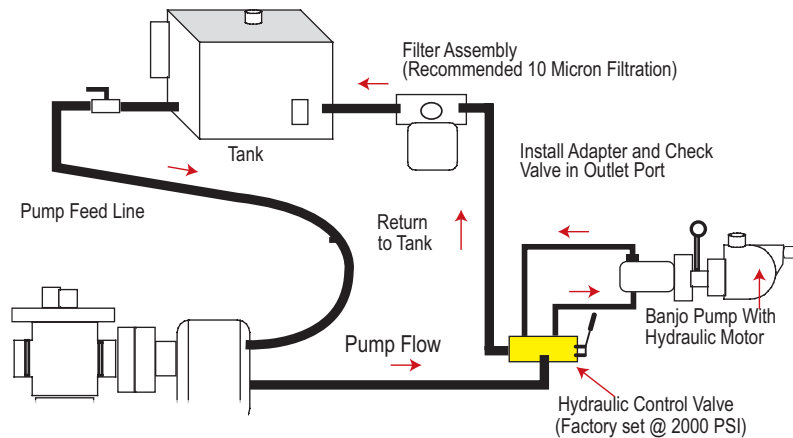

### HYDRAULIC MOTOR SPOOL VALVE

PART NO	DESCRIPTION	HP	QTY
HSV1000	HYDRAULIC MOTOR SPOOL VALVE	N/A	1

# CENTRIFUGAL PUMPS

## 3" CAST IRON PUMPS WITH HYDRAULIC MOTORS

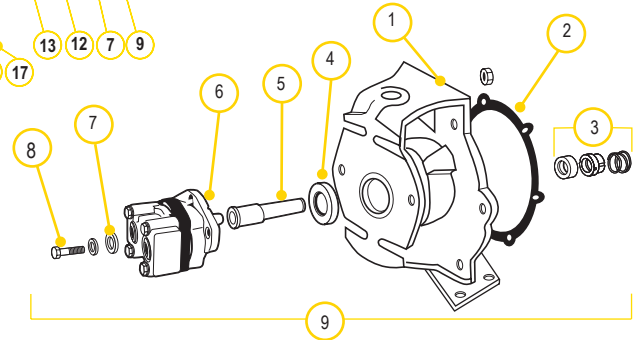
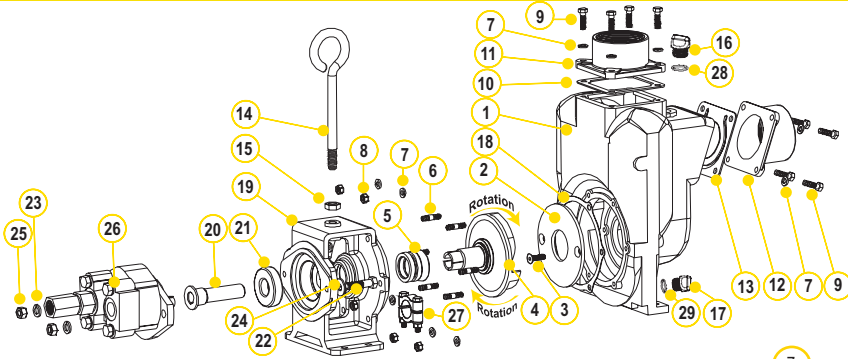

### REPLACEMENT PART 3" CAST IRON PUMPS

ITEM	PART NO	DESCRIPTION	QTY
1	18001	PUMP HOUSING	1
2	18004	WEAR PLATE	1
3	18106	3/8" - 16 X 1.25" HHCS	2
4	18023SS	1" IMPELLER & DRIVE SHAFT FOR GAS ENGINE	1
5	18025	FKM MECHANICAL SEAL	1
5	18025SD	SEVERE DUTY SEAL	1
6	18218	3/8" -16 X 24 X 2 1/8" SS STUD	6
7	V20018	3/8" LOCK WASHER	14
8	V20019	3/8" 16 SS HEX NUT	6
9	18010SS	3/8" - 16 X 1.25" HHCS	8
10	18009	EPDM OUTLET GASKET	1
11	18008	3" NPT OUTLET FLANGE	1
12	18012	3" NPT INLET FLANGE	1
13	18013	INLET/CHECK EPDM GASKET	1
14	18033	HANDLE	1
15	18034	5/8" -11 HEX NUT	1
16	13777	3/4" PLUG	1
17	12777	1/2" PLUG	1
18	18021	ADAPTER GASKET	1
19	18049	HYDRAULIC MOTOR ADAPTER	1
20	18055	HYDRAULIC ADAPTER SHAFT	1
21	18502	BEARING SKF 66306-2RS1/C3	1
22	18056	1/2" -13 X 2" HHCS	2
23	N/A	1/2" SPLIT WASHER	2
24	N/A	1/2" FLAT WASHER	2
25	17010	1/2" - 13 HEX NUT	2
26	HY1012	UM16-45A-HX HYDRAULIC MOTOR ASSEMBLY	1
27	18029	CLAMP ASSEMBLY UNKEYED	1
28	13778	O-RING	1
29	UV15163	O-RING	1
KIT	18100	REPAIR KIT (CONSIST OF 2, 3, 4, 5, 18)	1

### REPLACEMENT PARTS 3" HYDRAULIC ADAPTER

ITEM	PART NO	DESCRIPTION	QTY
1	18049	C-FACE HYDRAULIC MOTOR ADAPTER	1
2	18021	GASKET ADAPTER	1
3	18025	SEAL ASSEMBLY	1
4	18502	SKF 63306-2RS1/C3 BEARING	1
5	18055	HYDRAULIC ADAPTER SHAFT SLEEVE	1
6	HY1012	TYRONE® UM16 HYDRAULIC MOTOR	1
7	N/A	1/2" FLAT WASHER	2
8	N/A	1/2" SPLIT LOCK WASHER	2
9	18056	1/2" - 13" X 2" HHCS BOLT	2
10	17010	1/2" HEX NUT	2
11	18600	HYDRAULIC MOTOR ADAPTER ASSEMBLY	1
KIT	HY1001	REPAIR KIT	1

### HYDRAULIC MOTOR DATA

U.S. GALLONS/REV.	0.0038
CUBIC INCHES/REV.	0.878
LITERS/REV.	0.0144
MAX HYDRAULIC PRESSURE	3000 PSI
MIN HYDRAULIC PRESSURE	600 PSI
INLET PORT	1-1/16-12UN-2B
OUTLET PORT	1-5/16-12UN-2B
MINIMUM GPM REQUIRED	9 GPM 2370 RPM
MAXIMUM GPM REQUIRED	13 GPM 3450 RPM
IDEAL GPM REQUIRED	9 GPM 3600 RPM

### CONNECTION INFORMATION

INLET	"A" PORT
OUTLET	"B" PORT

SUPPLIED CHECK VALVE IS TO ENSURE PROPER ROTATION OF THE BANJO PUMP. PLACE CHECK VALVE IN OUTLET PORT (MARKED "B") FOR PROPER RIGHT HAND ROTATION. IT IS RECOMMENDED THAT A MINIMUM 3/4" INLET LINE & A MINIMUM 1" OUTLET LINE BE USED. THE OUTLET PORT MUST BE CONNECTED DIRECTLY BACK TO THE HYDRAULIC FLUID RESERVOIR & NOT TO ANY VALVING, REGULATORS OR FLOW DIVERTERS. THE OUTLET PORT/RETURN LINE BACK PRESSURE MUST NOT EXCEED 250 PSI.

### SPOOL VALVE INFORMATION

REQUIRED OUTLET FLOW	MIN 9 GPM / MAX 13 GPM
REQUIRED SYSTEM PRESSURE	MIN 600 PSI / MAX 3000 PSI

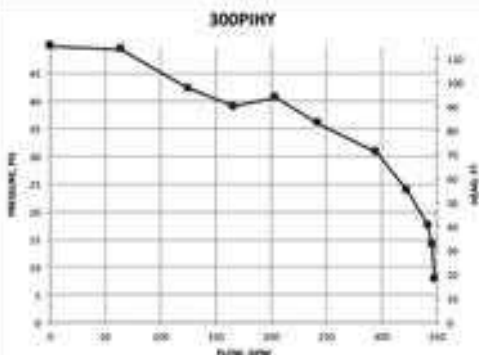

# CENTRIFUGAL PUMPS

## 3" 333 SERIES CAST IRON PUMPS

POWERED by  
**HONDA**

### FEATURES

- Cast iron construction for rugged dependable service
- Carbon ceramic seal with stainless steel cup and spring with FKM rubber
- Replaceable inlet and outlet flanges
- Dynamically balanced impeller
- Heavy duty slinger seal on motor shaft
- Large weep holes between pump end and engine
- Pedestal pump for long coupling to electric motor
- Due to weight and size of pumps, Banjo ships these by truck only.
- Engine warranty service available at authorized dealers



### 333 SERIES CAST IRON PUMPS W/GAS ENGINES

PART NO	DESCRIPTION	HP	QTY	SKID QTY
333PIH13	3" CAST IRON PUMP W/13 HP HONDA® ENGINE W/ ELECTRIC START & PULL ROPE	13	1	1



### 333 SERIES CAST IRON PUMP ONLYS

PART NO	DESCRIPTION	HP	QTY	SKID QTY
333POI	3" CAST IRON PUMP ONLY W/1" SHAFT & 5 VANE IMPELLER UNASSEMBLED	N/A	1	6
333POICF	3" CAST IRON PUMP ONLY W/ ELECTRIC MOTOR ADAPTER	N/A	1	6



### 333 SERIES CAST IRON BEARING PEDESTAL

PART NO	DESCRIPTION	HP	QTY	SKID QTY
333PBI	3" CAST IRON BEARING PEDESTAL W/ 1" SHAFT	N/A	1	6



### 333 SERIES CAST IRON HYDRAULIC PUMPS

PART NO	DESCRIPTION	HP	QTY	SKID QTY
333PIE15	3" CAST IRON PUMP W/15 HP THREE PHASE ELECTRIC MOTOR	15	1	1



**WARNING! DO NOT RUN PUMP DRY, RESTRICT OR REDUCE PORT SIZES OR DEAD HEAD PUMP**



**WARNING! DO NOT USE WITH FLAMMABLE LIQUIDS**

# CENTRIFUGAL PUMPS

## 3" 333 SERIES CAST IRON PUMPS

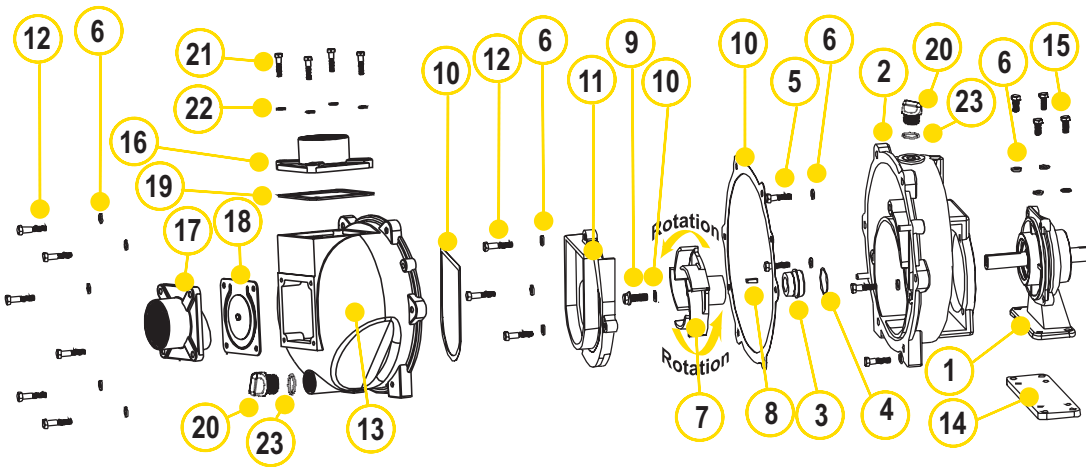

### REPLACEMENT PARTS 3" CAST IRON PUMPS

ITEM	PART NO	DESCRIPTION	QTY
N/S	16099	IMPELLER REMOVAL BOLT	1
1	18500	BEARING PEDESTAL (333PBI)	1
2	16704	REAR BRACKET	1
3	16713	MECHANICAL SEAL	1
4	16710	O-RING	1
5	17704	3/8" - 16 X 1.25" SS CAP SCREW (333PBI)	4
6	V20018	3/8" SS LOCK WASHER	17
7	16773	3" IMPELLER (333PBI)	1
7	16774	3" IMPELLER (333PIH13 & 333POI)	1
7	16774A	3" IMPELLER (333PIE15)	1
8	16901	1/4" SQ. 3/4" KEY STOCK	1
9	16765	IMPELLER BOLT (333PBI)	1
9	13765	IMPELLER BOLT (333PIH13)	1
10	16019	GASKET SET	1
11	16702	VOLUTE	1
12	N/A	3/8" - 16 X 1.75" SS BOLT	9
13	16733	BODY	1
14	18511	ADAPTER PLATE (333PBI)	1
15	18512	3/8" - 16 X 0.875" SS HHCS (333PBI)	4
N/S	16751	BRACKET SHIM SET	1
N/S	16752	IMPELLER SHIM	1
N/S	18033	HANDLE	1
N/S	18034	5/8" SS JAM NUT	1
16	16001	3" NPT OUTLET FLANGE	1
17	16003	3" NPT INLET FLANGE	1
18	16706	FKM INLET GASKET W/ CHECK	1
19	16011	FKM OUTLET GASKET	1
20	13777	3/4" PLUG	2
21	18027	3/8" - 16 X 1.50" HHCS (333PIH13)	8
22	V20018	3/8" SS LOCK WASHER	8
23	13778	O-RING	2
NS	16100	REPAIR KIT (CONSIST OF ITEMS 3, 4, 8, 10, 16751, 16752, 16099, 23)	1

### REPLACEMENT PARTS 333PIE15

ITEM	PART NO	DESCRIPTION	QTY
N/S	16099	IMPELLER REMOVAL BOLT	1
2	16704A	REAR BRACKET W/C-FACE ADAPTER	1
3	15025	MECHANICAL SEAL	1
6	V20018	3/8" SS LOCK WASHER	8
7	N/A	3" IMPELLER - 5 VANE	1
8	N/A	1/4" SQ. 3/4" KEY STOCK	1
9	16765	7/16-20 1 1/4" HFS	1
10	16019	GASKET SET	1
11	16702	VOLUTE	1
12	N/A	3/8" - 16 X 1.75" SS BOLT	9
13	16733	BODY	1
N/S	16751	BRACKET SHIM SET	1
N/S	16752	IMPELLER SHIM	1
N/S	18033	HANDLE	1
N/S	18034	5/8" SS JAM NUT	1
16	16001	OUTLET FLANGE	1
17	16003	INLET FLANGE	1
18	16706	FKM INLET GASKET W/ CHECK	1
19	16011	FKM OUTLET GASKET	1
20	13777	3/4" PLUG	2
21	18027	3/8" - 16 X 1.50" HHCS	8
22	V20018	3/8" SS LOCK WASHER	4
23	13778	O-RING	2

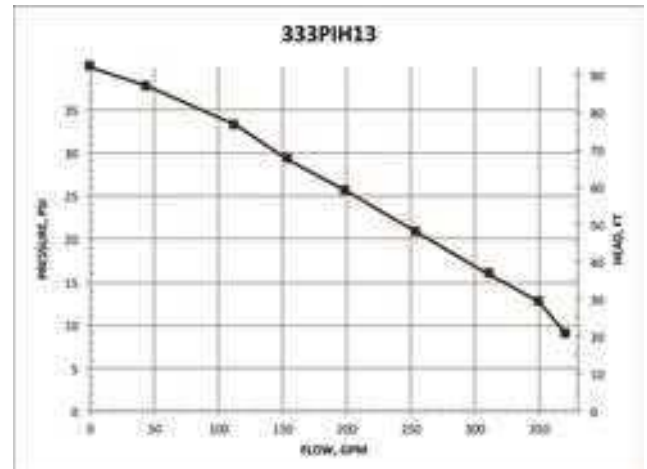

# CENTRIFUGAL PUMPS

## 3" M332 SERIES CAST IRON MANIFOLD WET SEAL PUMPS

### FEATURES

- Run dry capability
- Cast iron construction for rugged dependable service
- Carbon ceramic seal with stainless steel cup and spring with EPDM rubber
- Replaceable inlet and outlet flanges
- Dynamically balanced impeller
- Heavy duty slinger seal on motor shaft
- Due to weight and size of pumps, Banjo ships these by truck only.
- Engine warranty service available at authorized dealers
- See pages 43-49 on manifold fittings for easy plumbing.



WARNING! DO NOT USE WITH FLAMMABLE LIQUIDS



### M332 SERIES CAST IRON WET SEAL PUMPS W/GAS ENGINES

PART NO	DESCRIPTION	HP	QTY	SKID QTY
M332PIH13W	3" MANIFOLD CAST IRON WET SEAL PUMP W/13 HP HONDA® ENGINE W/ELECTRIC START & PULL ROPE	13	1	6



### M332 SERIES CAST IRON WET SEAL PUMPS W/ELECTRIC MOTORS

PART NO	DESCRIPTION	HP	QTY	SKID QTY
M332PIE10W	3" MANIFOLD CAST IRON WET SEAL PUMP W/10HP THREE PHASE ELECTRIC MOTOR	10	1	3
M332PIE101W	3" MANIFOLD CAST IRON WET SEAL PUMP W/10HP SINGLE PHASE ELECTRIC MOTOR	10	1	1

### M332 SERIES CAST IRON WET SEAL PUMP ONLY

PART NO	DESCRIPTION	HP	QTY	SKID QTY
M332POIW	3" MANIFOLD CAST IRON WET SEAL PUMP ONLY	N/A	1	6

# CENTRIFUGAL PUMPS

## 3" M332 SERIES CAST IRON MANIFOLD WET SEAL PUMPS

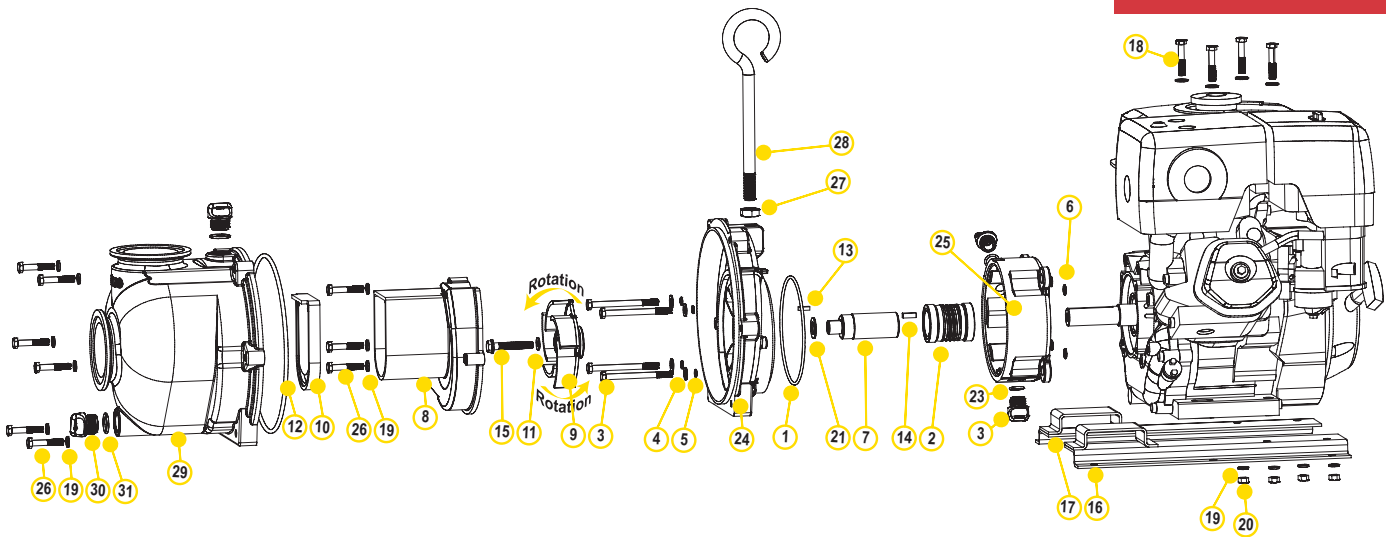

### REPLACEMENT PARTS M332 SERIES CAST IRON PUMPS

ITEM	PART NO	DESCRIPTION	QTY
1	13719	O-RING	1
2	15035E	EPDM MECHANICAL SEAL ASSEMBLY	1
3	13034	5/16" - 24 X 3/4" HHCS	1
4	12901	5/16" FLAT WASHER	4
5	12717	O-RING FOR BRACKET SCREW	8
6	12709	O-RING	4
7	13055	ADAPTER SHAFT	4
8	19702	VOLUTE	1
9	19772SS	5 VANE IMPELLER	1
9	15772	IMPELLER (M332PBIW)	1
10	12705	CHECK VALVE	1
11	A204	O-RING	1
12	12719A	BODY O-RING	1
13	12902A	IMPELLER KEY	1
14	16901	1/4" SQ X 3/4" KEY STOCK	1
15	13766	3/8" - 24 X 2 1/4" HFS	1
16	N/A	Z-RAIL	1
17	N/A	Z-RAIL	1
18	N/A	5/16" - 18 X 1 1/4" HHCS	4
19	V10118	5/16" LOCK WASHER	13
20	V10119	5/16" HEX NUT	4
21	CV10175	GASKET	2
22	12777	1/2" PLUG	2
23	UV15163	O-RING	2
24	19703W	REAR BRACKET	1
25	19201W	WET SEAL RESERVOIR	1
26	12715A	5/16" - 24 X 1 3/4" HHCS	9
27	18034	5/8"-11 JAM NUT	1
28	18033	PUMP HANDLE	1
29	M19712X	PUMP BODY	1
30	13777	3/4" PLUG	2
31	13778	O-RING	2

### REPLACEMENT PARTS M332 SERIES CAST IRON PUMPS

ITEM	PART NO	DESCRIPTION	QTY
N/S	18135A	Z-RAIL (HALF OF PAIR) USED ON 13 HP MODELS	1
N/S	18135B	Z-RAIL (HALF OF PAIR) USED ON 13 HP MODELS	1
KIT	M33200	CONTAINS #1, 2, 5, 6, 10, 11, 12, 21, 23, 31	1
NS	BEM10-100	10 HP, 215TC, 3 PH, 1" SHAFT	1
NS	BEM101-100	10HP, 215TC, 1 PH, 1" SHAFT	1

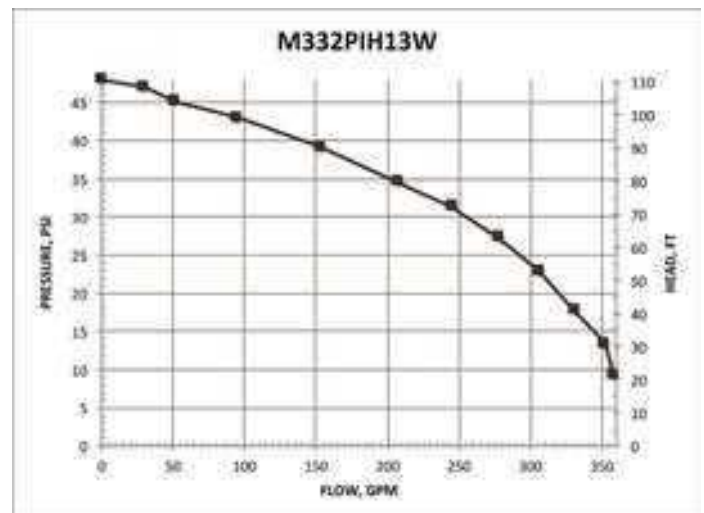

# CENTRIFUGAL PUMPS

## 3" M332 SERIES CAST IRON MANIFOLD WET SEAL PUMPS WITH HYDRAULIC MOTORS

### FEATURES

- Run dry capability
- Cast iron construction for rugged dependable service
- Carbon ceramic seal with stainless steel cup and spring with EPDM rubber
- Replaceable inlet and outlet flanges
- Dynamically balanced impeller
- Heavy duty slinger seal on motor shaft
- Hydraulic fluid capacity is minimum 9 gallons and maximum 13 gallons
- Open or closed system
- 3600 R.P.M.
- Recommendation to use the motor spool control valve or a suitable equivalent. The lack of such a valve in this circuit may cause failure to the hydraulic motor and will void warranty.
- See pages 43-49 on manifold fittings for easy plumbing.



M332 SERIES CAST IRON MANIFOLD WET SEAL PUMPS W/O HYDRAULIC MOTOR					
PART NO	DESCRIPTION	HP	QTY	SKID QTY	
M332PIHYW	3" MANIFOLD CAST IRON WET SEAL PUMP W/ HYDRAULIC MOTOR	21	1	8	
M332PIHAW	3" MANIFOLD CI WET SEAL PUMP WITHOUT HYDRAULIC MOTOR	N/A	1	1	

### SPOOL VALVE ASSEMBLY DIAGRAM

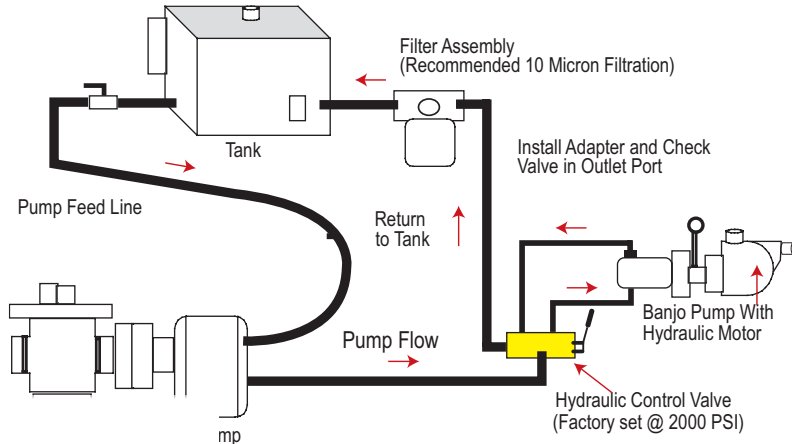

**WARNING! DO NOT USE WITH FLAMMABLE LIQUIDS**



### HYDRAULIC MOTOR SPOOL VALVE

PART NO	DESCRIPTION	HP	QTY
HSV1000	HYDRAULIC MOTOR SPOOL VALVE	N/A	1

# CENTRIFUGAL PUMPS

**3" M332 SERIES CAST IRON MANIFOLD WET SEAL PUMPS WITH HYDRAULIC MOTORS**

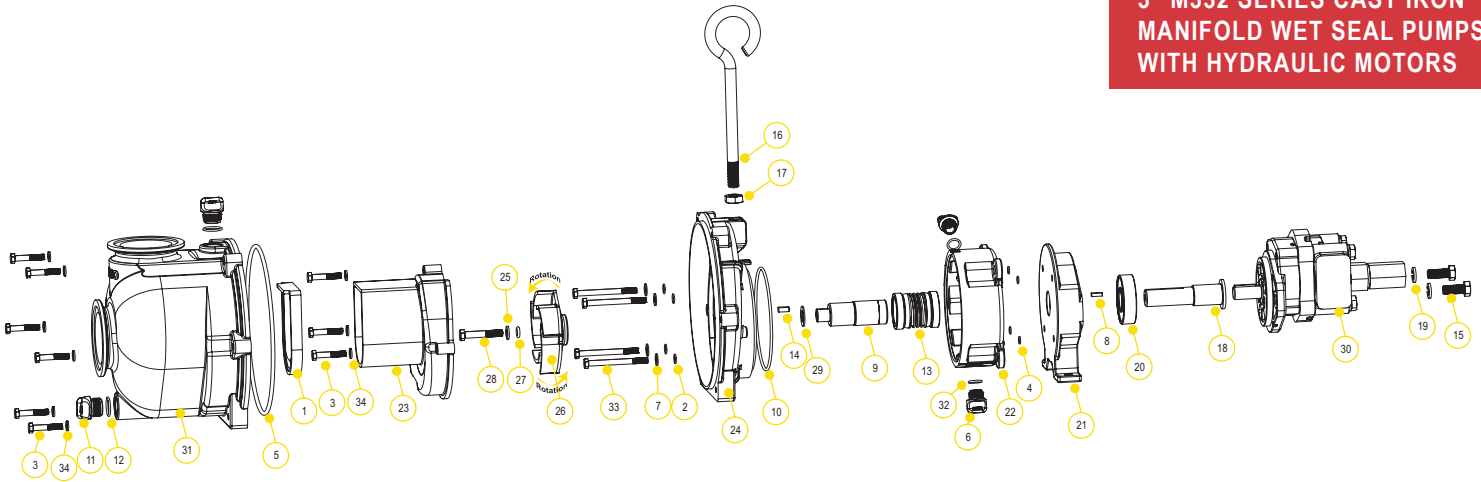

## REPLACEMENT PARTS M332 SERIES CAST IRON PUMPS

ITEM	PART NO	DESCRIPTION	QTY
1	12705	CHECK VALVE	1
2	12709	O-RING	4
3	12715A	SS BRACKET SCREWS-	9
4	12717	O-RING FOR SCREW HEAD	4
5	12719A	BODY O-RING	1
6	12777	1/2" PLUG	2
7	12901	SS REAR BRACKET WASHER	4
8	12902A	IMPELLER KEY	1
9	13055	ADAPTER SHAFT	1
10	13719	O-RING	1
11	13777	3/4" PLUG	2
12	13778	O-RING	2
13	15035E	EPDM MECHANICAL SEAL ASSEMBLY	1
14	16901	1/4" SQ. 3/8" KEY STOCK	1
15	N/A	BOLT	2
16	18033	HANDLE	1
17	18034	5/8" SS JAM NUT	1
18	18055H	HYDRAULIC MOTOR ADAPTER SHAFT	1
19	N/A	1/2" SPLIT LOCK WASHER	2
20	18502	SKF 63306-2RS1/C3 BEARING	1
21	19001H	RESERVOIR BACKING PLATE	1
22	19201W	WET SEAL RESERVOIR	1
23	19702	VOLUTE	1
24	19703W	REAR BRACKET	1
25	N/A	3/8" FLAT WASHER	1
26	19772SS	5 VANE IMPELLER	1
27	A204	O-RING	1
28	BF311	3/8" - 16 X 3" HHCS	1
29	CV10175	GASKET	1
30	HY1012	TYRONE® UM16 HYDRAULIC MOTOR	1
31	M19712X	PUMP BODY	1
32	UV15163	PRIME/DRAIN PLUG O-RING	2
33	V10118	5/16" SS LOCK WASHER	4
34	V10117	5/16" X 3 1/2" SS BODY BOLT	9

## HYDRAULIC MOTOR DATA

U.S. GALLONS/REV.	0.0038
CUBIC INCHES/REV.	0.878
LITERS/REV.	0.0144
MAX HYDRAULIC PRESSURE	3000 PSI
MIN HYDRAULIC PRESSURE	600 PSI
INLET PORT	1-1/16-12UN-2B
OUTLET PORT	1-5/16-12UN-2B
MINIMUM GPM REQUIRED	9 GPM 2370 RPM
MAXIMUM GPM REQUIRED	13 GPM 3450 RPM
IDEAL GPM REQUIRED	9 GPM 3600 RPM

## CONNECTION INFORMATION

INLET	"A" PORT
OUTLET	"B" PORT

SUPPLIED CHECK VALVE IS TO ENSURE PROPER ROTATION OF THE BANJO PUMP. PLACE CHECK VALVE IN OUTLET PORT (MARKED "B") FOR PROPER RIGHT HAND ROTATION. IT IS RECOMMENDED THAT A MINIMUM 3/4" INLET LINE & A MINIMUM 1" OUTLET LINE BE USED. THE OUTLET PORT MUST BE CONNECTED DIRECTLY BACK TO THE HYDRAULIC FLUID RESERVOIR & NOT TO ANY VALVING, REGULATORS OR FLOW DIVERTERS. THE OUTLET PORT/RETURN LINE BACK PRESSURE MUST NOT EXCEED 250 PSI.

## SPOOL VALVE INFORMATION

REQUIRED OUTLET FLOW	MIN 9 GPM / MAX 13 GPM
REQUIRED SYSTEM PRESSURE	MIN 600 PSI / MAX 3000 PSI

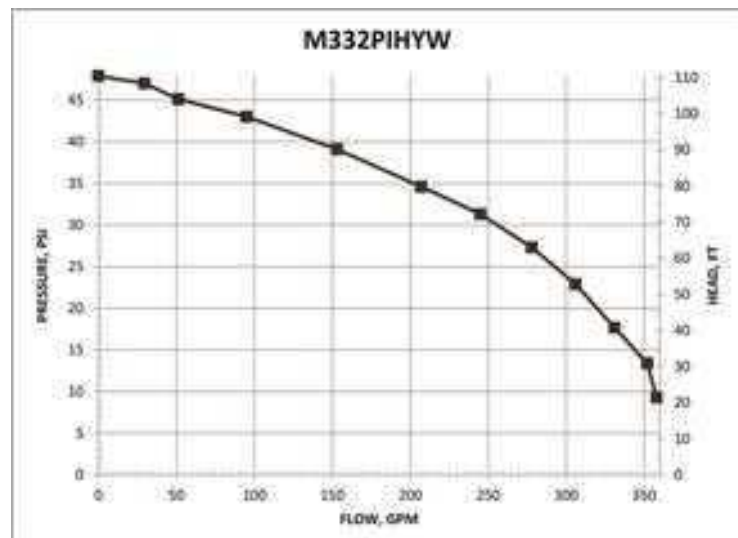

# CENTRIFUGAL PUMPS

## 4" 444 SERIES CAST IRON PUMPS

### FEATURES

- Cast iron construction for rugged dependable service
- Carbon ceramic seal with stainless steel cup and spring with FKM rubber
- Replaceable inlet and outlet flanges
- Dynamically balanced impeller
- Heavy duty slinger seal on motor shaft
- Large weep holes between pump end and engine
- Recommendation for 444POI: use with 10 pound per gallon material or more
- Due to weight and size of pumps, Banjo ships these by truck only.
- Engine warranty service available at authorized dealers



### 444 SERIES CAST IRON PUMPS W/GAS ENGINES

PART NO	DESCRIPTION	HP	QTY	SKID QTY
444PIH24	4" CAST IRON PUMP W/24 HP HONDA® ENGINE	24	1	1



### 444 SERIES CAST IRON PUMP BEARING PEDESTAL

PART NO	DESCRIPTION	HP	QTY	SKID QTY
444PBI	4" CAST IRON PUMP W/BEARING PEDESTAL W/ 1" SHAFT & 5 VANE IMPELLER	N/A	1	6



### 444 SERIES CAST IRON PUMP ONLYS

PART NO	DESCRIPTION	HP	QTY	SKID QTY
444POI	4" CAST IRON PUMP ONLY W/ 1 1/4" X 3 1/2" SHAFT & 6 VANE IMPELLER UNASSEMBLED	N/A	1	6



WARNING! DO NOT RUN PUMP DRY, RESTRICT OR REDUCE PORT SIZES OR DEAD HEAD PUMP



WARNING! DO NOT USE WITH FLAMMABLE LIQUIDS

# CENTRIFUGAL PUMPS

## 4" 444 SERIES CAST IRON PUMPS

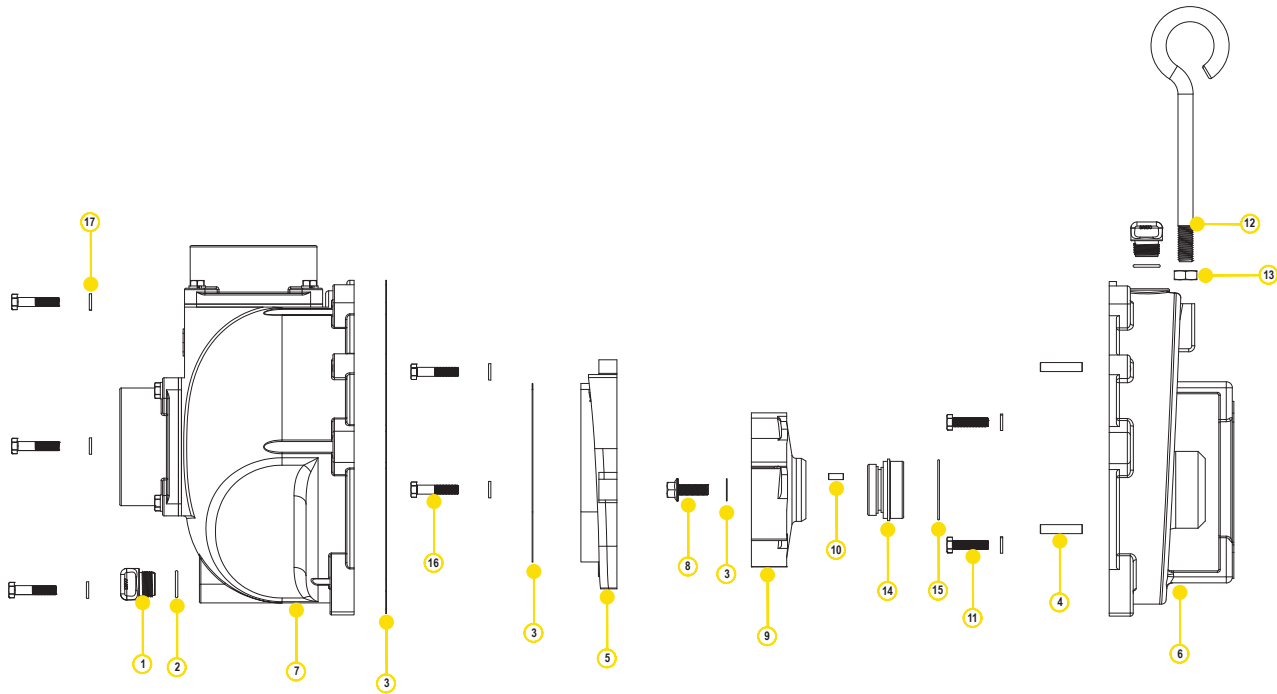

### REPLACEMENT PARTS 4" CAST IRON PUMPS

ITEM	PART NO	DESCRIPTION	QTY
1	13777	3/4" PLUG	2
2	13778	O-RING	2
3	16019	GASKET	1
4	N/A	3/8" X 1 1/4" DOWELL PIN	2
5	16702	VOLUTE	1
6	16707	REAR BRACKET	1
7	16712	BODY	1
8	16765	IMPELLER BOLT	1
9	16775	4" IMPELLER	1
10	16901	1/4" SQ. 3/4" KEY STOCK	1
11	18027	3/8" - 16 X 1.50" HHCS	4
12	18033	HANDLE	1
13	18034	5/8" SS JAM NUT	1
14	18435	MECHANICAL SEAL	1
15	V10264	O-RING	1
16	N/A	3/8"-16 X 1 1/4" HHCS	9
17	V20018	3/8" SS LOCK WASHER	13

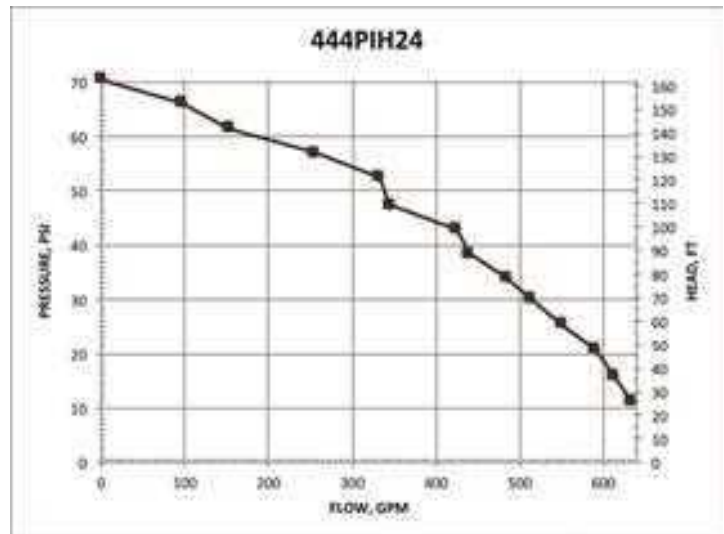

**Note:** Please see repair parts list for 444PBI on our website.

# CENTRIFUGAL PUMPS

## 2" STAINLESS STEEL PUMPS

### FEATURES

- ALL FKM SEALS
- 316 stainless steel housing and wettable internal components including impeller, sleeve, wear plate and fasteners
- Carbon ceramic seal with 316 stainless steel cup and spring with FKM elastomer
- Replaceable inlet and outlet flanges
- Dynamically balanced impeller
- Pump only packs complete and ready for attachment to gasoline engine
- Pedestal pump for long coupling to electric motor
- Recommendation for  $\frac{5}{8}$ " shaft: 56C frame size, 3 HP, 3450 RPM & 5" max impeller for close coupling to electric motors
- Recommendation for  $\frac{7}{8}$ " shaft: 145TC frame size, 3 HP, 3450 RPM & 5" max impeller for close coupling to electric motors
- Engine warranty service available at authorized dealers
- Due to weight and size of pumps, Banjo ships these by truck only.



WARNING! DO NOT RUN PUMP DRY, RESTRICT OR REDUCE PORT SIZES OR DEAD HEAD PUMP



WARNING! DO NOT USE WITH FLAMMABLE LIQUIDS



### 2" STAINLESS STEEL PUMPS W/GAS ENGINES

PART NO	DESCRIPTION	HP	QTY	SKID QTY
200PH6SS	2" SS PUMP W/6.5 HP HONDA® ENGINE W/ PULL ROPE ONLY	5.5	1	8



### 2" STAINLESS STEEL PUMP ONLY

PART NO	DESCRIPTION	HP	QTY	SKID QTY
200PO-SS	2" SS PUMP ONLY W/ $\frac{3}{4}$ " SHAFT SLEEVE	N/A	1	27



### 2" STAINLESS STEEL C-FACE PUMPS

PART NO	DESCRIPTION	HP	QTY	SKID QTY
200POSSCF5/8	2" SS C-FACE PUMP W/ $\frac{5}{8}$ " SHAFT SLEEVE	N/A	1	18



### 2" STAINLESS STEEL BEARING PEDESTAL

PART NO	DESCRIPTION	HP	QTY	SKID QTY
200PB-SS	2" SS BEARING PEDESTAL W/ $\frac{3}{4}$ " STRAIGHT SHAFT*	N/A	1	18

# CENTRIFUGAL PUMPS

## 2" STAINLESS STEEL PUMPS

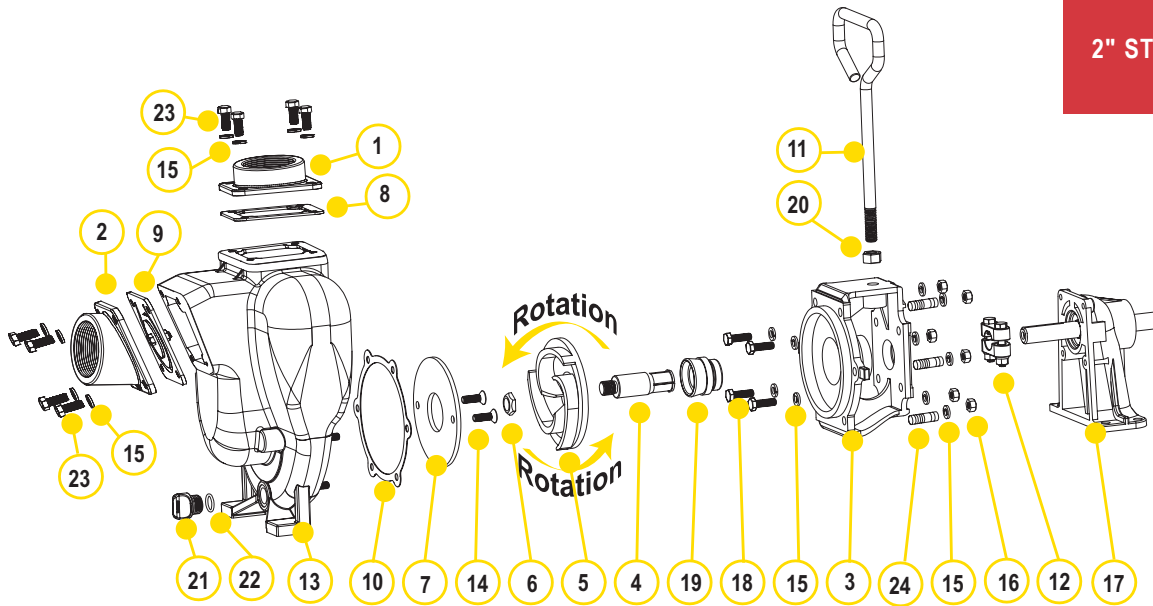

### REPLACEMENT PARTS 2" STAINLESS STEEL PUMPS

ITEM	PART NO	DESCRIPTION	QTY
1	17000SS	2" NPT SS OUTLET FLANGE	1
2	17002SS	2" NPT SS INLET FLANGE	1
3	17004SS	SS ADAPTER FOR GAS ENGINE	1
3	17046SS	CF ADAPTER FOR ELECTRIC MOTOR	1
4	17005	5/8" SS SLEEVE DRIVE	1
4	17006	3/4" SS SLEEVE DRIVE	1
4	17007	7/8" SS SLEEVE DRIVE	1
5	17008SS	SS IMPELLER	1
5	N/A	4.1" SS IMPELLER	1
5	N/A	4.6" SS IMPELLER	1
6	17009B	5/8" IMPELLER NUT	1
7	17011SS	SS WEAR PLATE	1
8	17014	FKM OUTLET GASKET	1
9	17017	FKM CHECK VALVE ASSEMBLY GASKET	1
10	17018	ADAPTER GASKET	1
11	15022	HANDLE	1
12	17023	5/8" CLAMP, 3/4" SS SHAFT (OLD STYLE)	1
12	17123	5/8" CLAMP, 3/4" SS SHAFT (KEYED CLAMP)	1
12	17024	7/8" CLAMP, 3/4" SS SHAFT	1
13	17026SS	SS PUMP HOUSING	1
14	17130SS	5/16-18 X 1.00" FHSCS, 316 SS	2
15	V10118	5/16" LOCK WASHER	18
16	V10119	5/16" -18 SS HEX NUT	6
17	12882A	BEARING PEDESTAL ASSEMBLY W/ 3/4" SHAFT	1
18	17040	BOLT	4
19	17035SS	FKM SS SEAL ASSEMBLY	1
20	17010	1/2" - 24 X 1" HHCS	1
21	12777SS	1/2" STAINLESS STEEL PLUG	1
22	UV15163V	O-RING FKM	1
23	17019	5/16" - 18 X 3/4" CAP SCREW	8
24	17042	STUD	6
KIT	17100SS	PUMP REPAIR KIT(CONSISTS OF 4,5,7,10,14,19)	1

### KITS 2" SS PUMPS

PART NO	FKM REPAIR KIT NO
200PH6SS	17100SS
200PB-SS	17100SS
200PO-SS	17100SS

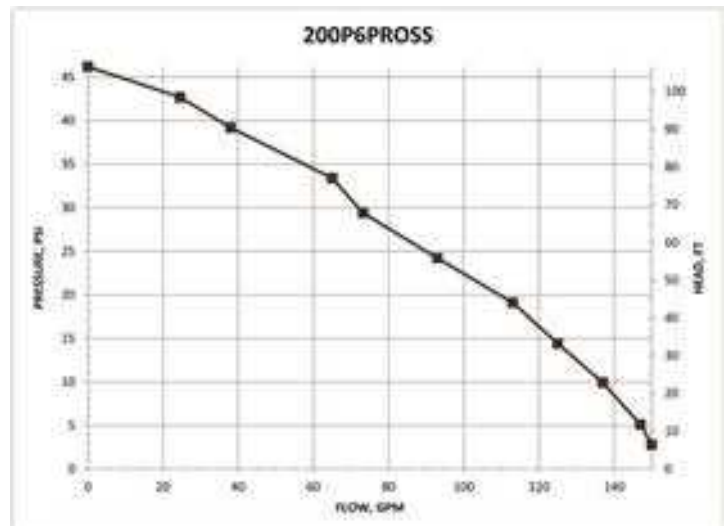

# CENTRIFUGAL PUMPS

## 2" STAINLESS STEEL PUMPS WITH ELECTRIC MOTORS

### FEATURES

- Stainless steel construction for rugged dependable service
- Stainless steel shaft sleeve to protect engine shaft
- Replaceable inlet and outlet flanges
- Dynamically balanced impeller
- Due to weight and size of pumps, Banjo ships these by truck only.
- Motor warranty service available at authorized dealers
- Motor features include pressure cast aluminum end plates with ribbed design for rigidity, heavy gauge steel frame, 230 volt, with inverter spike resistance magnet wire



### 2" STAINLESS STEEL PUMPS W/ELECTRIC MOTORS

PART NO	DESCRIPTION	HP	QTY	SKID QTY
234PE5SS	2" STAINLESS STEEL PUMP W/5 HP THREE PHASE ELECTRIC MOTOR	5	1	3



WARNING! DO NOT RUN PUMP DRY, RESTRICT OR REDUCE PORT SIZES OR DEAD HEAD PUMP



WARNING! DO NOT USE WITH FLAMMABLE LIQUIDS

# CENTRIFUGAL PUMPS

2" STAINLESS STEEL PUMPS WITH ELECTRIC MOTORS

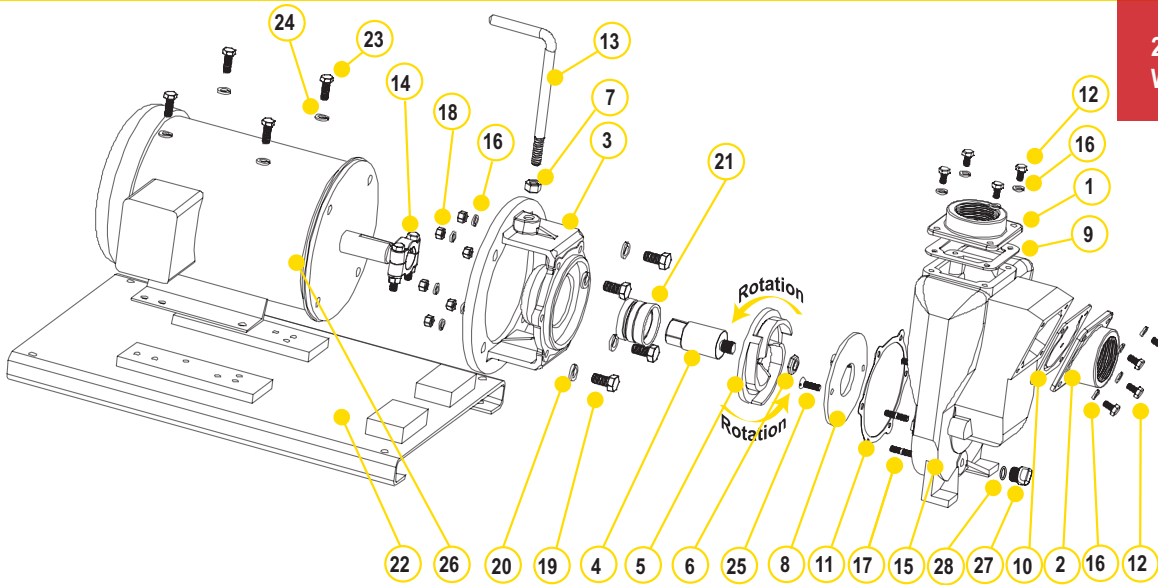

## REPLACEMENT PARTS 2" STAINLESS STEEL PUMPS

ITEM	PART NO	DESCRIPTION	QTY
1	17000SS	2" NPT OUTLET FLANGE	1
2	17002SS	2" NPT INLET FLANGE	1
3	17446SS	C-FACE ADAPTER	1
4	17406	IMPELLER SHAFT	1
5	17408SS	IMPELLER	1
6	17009B	5/8" IMPELLER NUT	1
7	17010	1/2" HEX NUT	1
8	17011SS	WEAR PLATE	1
9	17014	FKM OUTLET GASKET	1
10	17017	FKM GASKET & CHECK VALVE	1
11	17018	ADAPTER GASKET	1
12	17019	BOLT	8
13	15022	HANDLE	1
14	18129	CLAMP ASSEMBLY	1
15	17026SS	PUMP HOUSING	1
16	V10118	5/16" LOCK WASHER	20
17	17042	HOUSING STUD	6
18	V10119	HEX NUT	8
19	N/A	BOLT	4
20	N/A	WASHER	4
21	18025SS	SEAL ASSEMBLY	1
22	17701	BASE PLATE ASSEMBLY	1
23	17704	BOLT	4
24	V20018	3/8" LOCK WASHER	4
25	17130SS	5/16-18 X 1.00" FHSCS, 316 SS	2
26	N/A	ELECTRIC MOTOR	1
27	12777SS	1/2" STAINLESS STEEL PLUG	1
28	UV15163V	FKM O-RING	1

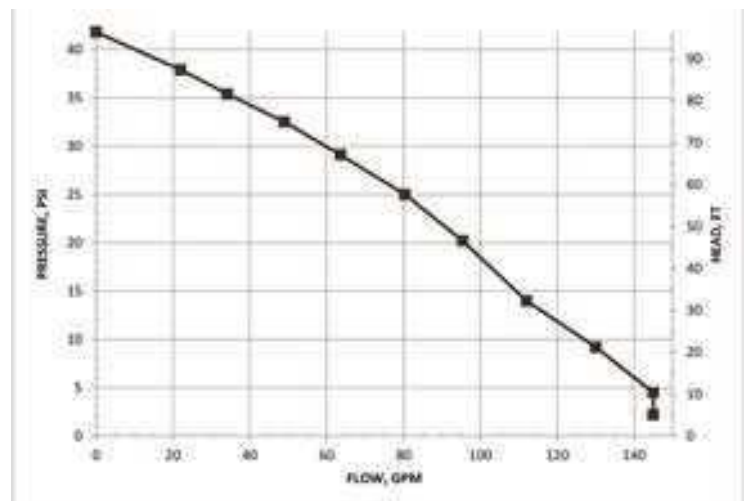

# CENTRIFUGAL PUMPS

## 2" STAINLESS STEEL PUMPS WITH HYDRAULIC MOTORS

### FEATURES

- Cast iron construction for rugged dependable service
- Stainless steel hardware
- Replaceable inlet and outlet flanges
- Dynamically balanced impeller
- Hydraulic fluid capacity is minimum 6 gallons and maximum 10 gallons
- Open or closed system
- 12 HP motor
- Recommendation to use the motor spool control valve or a suitable equivalent. The lack of such a valve in this circuit may cause failure to the hydraulic motor and will void warranty.



### 2" STAINLESS STEEL PUMPS W/ HYDRAULIC MOTORS

PART NO	DESCRIPTION	HP	QTY	SKID QTY
200PHYSS	2" STAINLESS STEEL PUMP W/ 12 HP HYDRAULIC MOTOR	12	1	18



**WARNING! DO NOT RUN PUMP DRY, RESTRICT OR REDUCE PORT SIZES OR DEAD HEAD PUMP**



**WARNING! DO NOT USE WITH FLAMMABLE LIQUIDS**

### SPOOL VALVE ASSEMBLY DIAGRAM

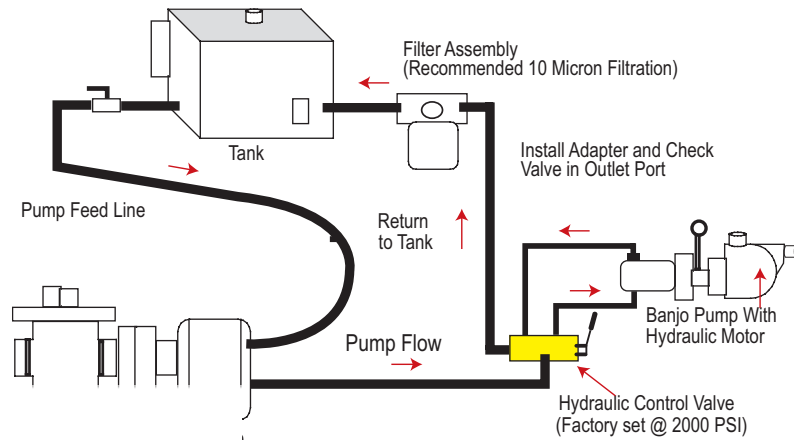

### HYDRAULIC MOTOR SPOOL VALVE

PART NO	DESCRIPTION	HP	QTY
HSV1000	HYDRAULIC MOTOR SPOOL VALVE	N/A	1

# CENTRIFUGAL PUMPS

2" STAINLESS STEEL PUMPS WITH HYDRAULIC MOTORS

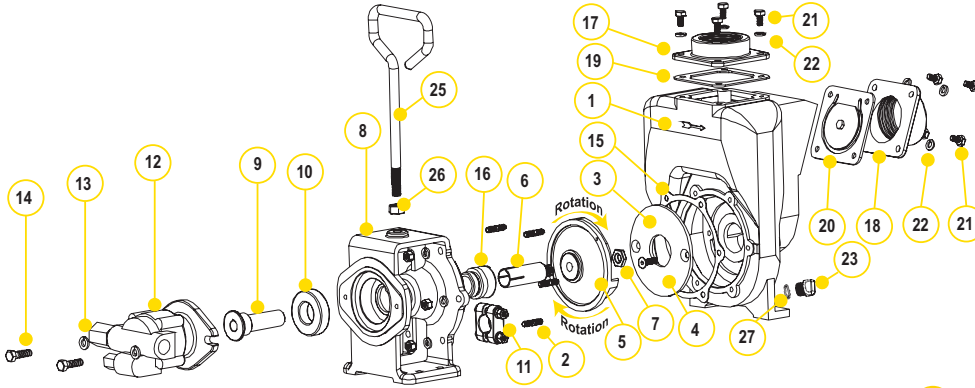

## REPLACEMENT PARTS 2" STAINLESS STEEL PUMPS

ITEM	PART NO	DESCRIPTION	QTY
1	17026SS	PUMP HOUSING	1
2	17042	PUMP HOUSING STUD	6
3	17011SS	WEAR PLATE	1
4	17130SS	5/16-18 X 1.00" FHSCS, 316 SS	2
5	17008SS	5" IMPELLER	1
6	17007	7/8" SLEEVE DRIVE FOR ELECTRIC MOTOR	1
7	17009B	5/8" IMPELLER NUT	1
8	17049ASS	HYDRAULIC ADAPTER	1
9	17055A	HYDRAULIC ADAPTER SHAFT	1
10	17056	SKF 6206-2RS1 BEARING	1
11	17024	7/8" CLAMP, NO KEY	1
12	HY1013	MGG20025BC1D3 HYDRAULIC MOTOR ASSEMBLY	1
13	V20018	3/8" LOCK WASHER	2
14	18010SS	3/8" - 16 X 1.25" HHCSS	2
15	17018	GASKET ADAPTER	1
16	17035SS	FKM SEAL ASSEMBLY	1
17	17000SS	2" NPT OUTLET FLANGE	1
18	17002SS	2" NPT INLET FLANGE	1
19	17014	FKM GASKET	1
20	17017	GASKET CHECK VALVE ASSEMBLY	1
21	17019	5/16" - 18 X 0.75" CAP SCREW	8
22	V10118	5/16" SPLIT LOCK WASHER	14
23	12777SS	1/2" STAINLESS STEEL PLUG	1
24	V10119	5/16"-18 HEX NUT	6
25	15022	HANDLE	1
26	17010	1/2" HEX NUT -13UNF-RH	1
27	UV15163V	O-RING FKM	1

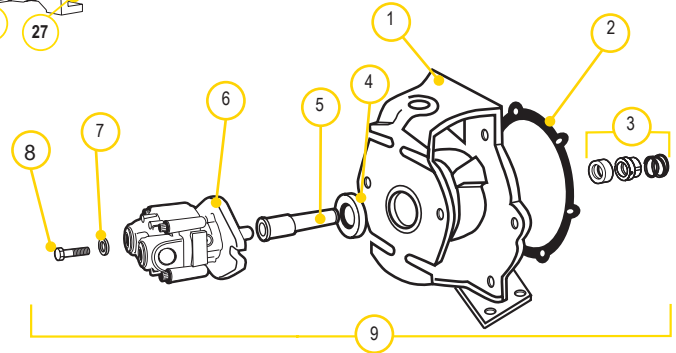

## HYDRAULIC MOTOR DATA

U.S. GALLONS/REV.	0.0025
CUBIC INCHES/REV.	0.580
LITERS/REV.	0.0097
MAX HYDRAULIC PRESSURE	2000 PSI
MIN HYDRAULIC PRESSURE	200 PSI
INLET PORT	SAE 10 (7/8-14 UNF-2B)
OUTLET PORT	SAE 10 (7/8-14 UNF-2B)
MINIMUM GPM REQUIRED	6 GPM 2400 RPM
MAXIMUM GPM REQUIRED	10 GPM 4000 RPM
IDEAL GPM REQUIRED	9 GPM 3600 RPM

## CONNECTION INFORMATION

INLET	"A" PORT
OUTLET	"B" PORT

SUPPLIED CHECK VALVE IS TO ENSURE PROPER ROTATION OF THE BANJO PUMP. PLACE CHECK VALVE IN OUTLET PORT (MARKED "B") FOR PROPER RIGHT HAND ROTATION.

## SPOOL VALVE INFORMATION

REQUIRED OUTLET FLOW	MIN 6 GPM / MAX 10 GPM
REQUIRED SYSTEM PRESSURE	MIN 500 PSI / MAX 2000 PSI

## REPLACEMENT PARTS 2" HYDRAULIC ADAPTER

ITEM	PART NO	DESCRIPTION	QTY
1	17049ASS	SS HYDRAULIC MOTOR ADAPTER	1
2	17018	GASKET ADAPTER	1
3	17035SS	SEAL ASSEMBLY	1
N/S	17007	7/8" SS SHAFT SLEEVE	1
4	17056	SKF 6206-2RS1 BEARING	1
5	17055A	HYDRAULIC ADAPTER SHAFT	1
6	HY1013	GRESER® HYDRAULIC MOTOR	1
7	V20018	LOCK WASHER	2
8	18010SS	BOLT	2

## 200PHYSS

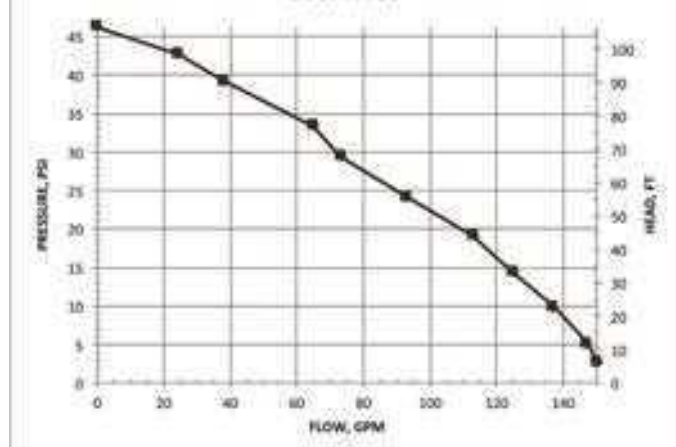

# CENTRIFUGAL PUMPS

## 3" STAINLESS STEEL PUMPS

### FEATURES

- 316 stainless steel housing and wettable internal components including impeller, sleeve, wear plate and fasteners
- Carbon ceramic seal with 316 stainless steel cup and spring with FKM elastomer
- Replaceable inlet and outlet flanges
- Dynamically balanced impeller
- Pump only packs complete and ready for attachment to gasoline engine
- Pedestal pump for long coupling to electric motor
- Recommendation for 5/8" shaft: 56C frame size, 3 HP, 3450 RPM & 5" max impeller for close coupling to electric motors
- Recommendation for 7/8" shaft: 145TC frame size, 3 HP, 3450 RPM & 5" max impeller for close coupling to electric motors
- Engine warranty service available at authorized dealers
- Due to weight and size of pumps, Banjo ships these by truck only.



WARNING! DO NOT RUN PUMP DRY, RESTRICT OR REDUCE PORT SIZES OR DEAD HEAD PUMP



WARNING! DO NOT USE WITH FLAMMABLE LIQUIDS



### 3" STAINLESS STEEL PUMPS W/GAS ENGINES

PART NO	DESCRIPTION	HP	QTY	SKID QTY
300PH13SS	3" SS PUMP W/13 HP HONDA® ENGINE W/ELECTRIC START & PULL ROPE	13	1	6



### 3" STAINLESS STEEL PUMP ONLY

PART NO	DESCRIPTION	HP	QTY	SKID QTY
300PO-SS	3" SS PUMP ONLY W/ 1" SHAFT SLEEVE	N/A	1	8



### 3" STAINLESS STEEL BEARING PEDESTAL

PART NO	DESCRIPTION	HP	QTY	SKID QTY
300PB-SS	3" SS BEARING PEDESTAL W/ 1" STRAIGHT SHAFT	N/A	1	8



### 3" STAINLESS STEEL PUMPS W/ HYDRAULIC MOTOR

PART NO	DESCRIPTION	HP	QTY	SKID QTY
300PHYSS	3" STAINLESS STEEL PUMP W/ 21 HP HYDRAULIC MOTOR	12	1	8

# CENTRIFUGAL PUMPS

## 3" STAINLESS STEEL PUMPS

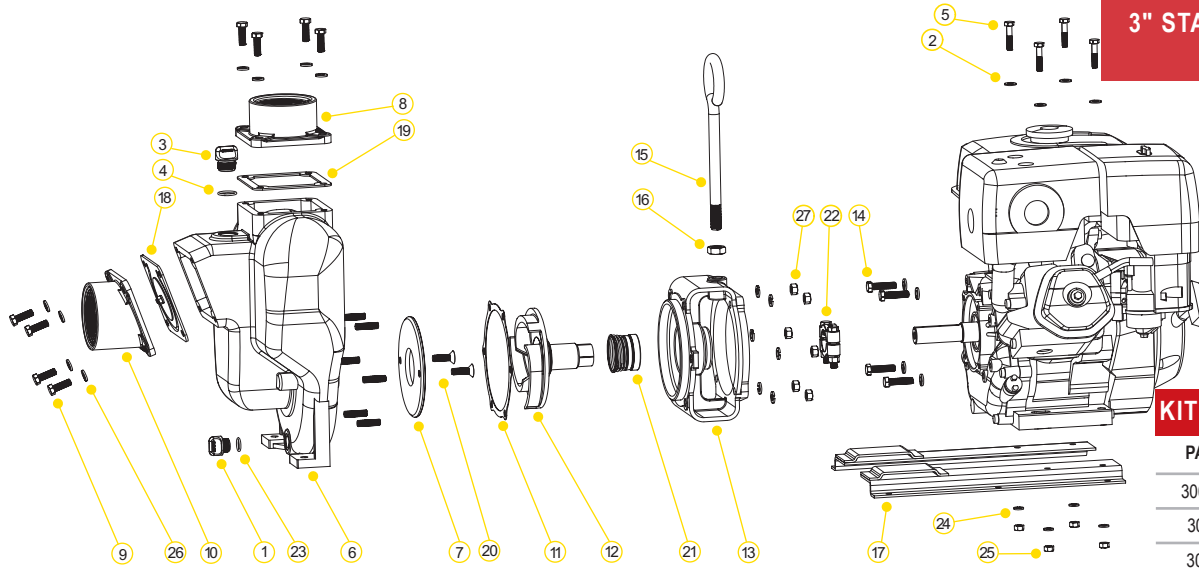

### KITS 3" SS STEEL PUMPS

PART NO	FKM REPAIR KIT NO
300PH13SS	18100SS
300PB-SS	18100SS
300PO-SS	18100SS

### REPLACEMENT PARTS 3" STAINLESS STEEL PUMPS

ITEM	PART NO	DESCRIPTION	QTY
1	12777SS	½" STAINLESS STEEL PLUG	1
2	12901	SS REAR BRACKET WASHER	4
3	13777SS	¾" STAINLESS STEEL PLUG	1
4	13778V	O-RING FKM	1
5	N/A	⅝" - 18 X 1¾" ZINC PLATED	4
6	18001SS	SS PUMP HOUSING	1
7	18004SS	SS WEAR PLATE	1
8	N/A	3" NPT OUTLET FLANGE	1
9	18010SS	⅜" - 16 X 1½" SS CAP SCREW HXHD	8
10	N/A	3" NPT INLET FLANGE	1
11	18021	ADAPTER GASKET	1
12	18023SS	1" SS IMPELLER & DRIVE SHAFT FOR GAS ENGINE	1
12	18023-1.125SS	1½" SS IMPELLER & DRIVE SHAFT FOR ELECTRIC MOTOR (300PO-SSCF)	1
13	18026SS	ADAPTER FOR GAS ENGINE	1
13	18049SS	ADAPTER FOR HYDRAULIC MOTOR (300PHYSS)	1
14	18027	⅜" - 16 X 1½" HHCS	4
15	18033	HANDLE	1
16	18034	⅝" SS JAM NUT	1
17	18035	Z RAILS	1
18	18042	FKM GASKET CHECKVALVE ASSEMBLY	1
19	18044	FKM OUTLET GASKET	1
20	18106SS	WEAR PLATE FLAT HEAD SCREW	2
21	18025SS	FKM SEAL ASSEMBLY	1
22	18129	CLAMP ASSEMBLY	1
23	UV15163V	O-RING FKM	1
24	V10118	⅝" LOCK WASHER	4
25	V10119	⅝" - 18 SS HEX NUT	4
26	V20018	⅜" SS LOCK WASHER	18
27	V20019	⅜" 16 SS HEX NUT	6
KIT	18100SS	REPAIR KIT(CONSIST OF ITEMS 7,11,12, 20 & 21)	1

### HYDRAULIC MOTOR DATA

U.S. GALLONS/REV.	0.0038
CUBIC INCHES/REV.	0.878
LITERS/REV.	0.0144
MAX HYDRAULIC PRESSURE	3000 PSI
MIN HYDRAULIC PRESSURE	600 PSI
INLET PORT	1-1/16-12UN-2B
OUTLET PORT	1-5/16-12UN-2B
MINIMUM GPM REQUIRED	9 GPM 2370 RPM
MAXIMUM GPM REQUIRED	13 GPM 3450 RPM
IDEAL GPM REQUIRED	9 GPM 3600 RPM

### CONNECTION INFORMATION

INLET	"A" PORT
OUTLET	"B" PORT

SUPPLIED CHECK VALVE IS TO ENSURE PROPER ROTATION OF THE BANJO PUMP. PLACE CHECK VALVE IN OUTLET PORT (MARKED "B") FOR PROPER RIGHT HAND ROTATION. IT IS RECOMMENDED THAT A MINIMUM ¾" INLET LINE & A MINIMUM 1" OUTLET LINE BE USED. THE OUTLET PORT MUST BE CONNECTED DIRECTLY BACK TO THE HYDRAULIC FLUID RESERVOIR & NOT TO ANY VALVING, REGULATORS OR FLOW DIVERTERS. THE OUTLET PORT/RETURN LINE BACK PRESSURE MUST NOT EXCEED 250 PSI.

### SPOOL VALVE INFORMATION

REQUIRED OUTLET FLOW	MIN 9 GPM / MAX 13 GPM
REQUIRED SYSTEM PRESSURE	MIN 600 PSI / MAX 3000 PSI

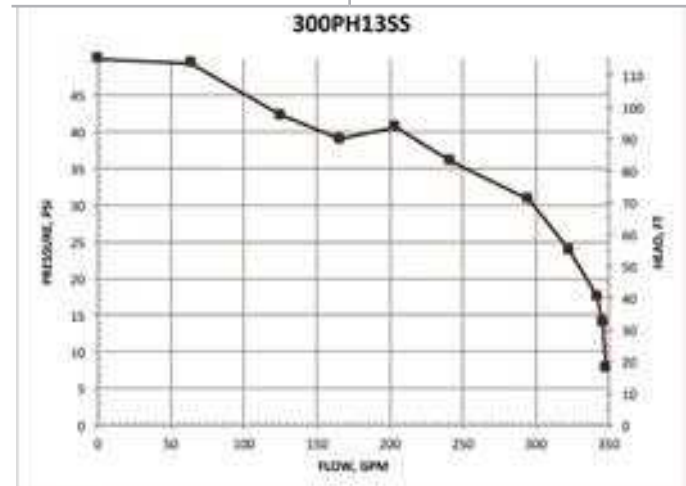

Note: Please see repair parts list for 300PHYSS on our website.

TANK WALL GUIDE FOR BANJO TANK FITTINGS		
PART NO	DESCRIPTION	MAX TANK WALL THICKNESS
BF075	¾" BLIND HOLE TANK FLANGE	.250
BF075D	¾" X 1" BOTTOM DRAIN FLANGE EPDM THREAD	.250
BF100	1" BLIND HOLE BOLTED TANK FLANGE	.250
BF100BD	1" X 1" BOTTOM DRAIN FLANGE EPDM THREAD	.250
BF150	1½" BOLTED TANK FLANGE	.280
BF150BD	1½" X 2" BOTTOM DRAIN FLANGE EPDM THREAD	.220
BF200	2" BLIND HOLE BOLTED TANK FLANGE	.280
BF200BD	2" X 2" BOTTOM DRAIN FLANGE EPDM THREAD	.220
BF200V	2" X 2" THREADED FLANGE W/FKM GASKET	.280
BF220	2" FULL PORT BOLTED TANK FLANGE	.250
BF220BD	2" X 2" FULL PORT BOTTOM DRAIN FLANGE EPDM THREAD	.250
BF300	3" X 3" BOLTED TANK FLANGE	.500
BF300BD	3" X 3" BOTTOM DRAIN FLANGE EPDM THREAD	.500
MBF100	1" BOLTED MANIFOLD TANK FLANGE WITH 2¼" BOLTS	.280
MBF100BD	1" BOTTOM DRAIN MANIFOLD BOLTED TANK FLANGE EPDM THREAD	.280
MBF200	2" BOLTED MANIFOLD TANK FLANGE WITH 2½" BOLTS	.210
MBF200BD	2" BOTTOM DRAIN MANIFOLD TANK FLANGE	.500
MBF220	2" FULL PORT MANIFOLD FLANGE WITH 2½" BOLTS	.320
MBF220BD	2" FULL PORT MANIFOLD BOTTOM DRAIN FLANGE EPDM THREAD	.550
MBF300	3" BOLTED MANIFOLD TANK FLANGE EPDM THREAD	.500
MBF300BD	3" BOTTOM DRAIN MANIFOLD TANK FLANGE EPDM THREAD	.500

BRIGGS & STRATTON ENGINES						
BANJO PART NUMBER	E3	E6.5PRO	E6.5PROE	E11PROE	E11PRO100E	E14VAN
MANUFACTURER	Briggs & Stratton	Briggs & Stratton	Briggs & Stratton	Briggs & Stratton	Briggs & Stratton	Vanguard
MODEL NUMBER	083132-1110-F1	130G32-0122-F1	130G37-0183-F1	19N137-0076-F1	2123320140B1G1016	25V337-0012-F1
RATED HP @ 3600 RPM	3.5	6.5	6.5	11	11	14
RATED TORQUE @ 2800 RPM	4.9 ft lbs	9 ft lbs	9 ft lbs	15.5 ft lbs	15.5 ft lbs	20.8 ft lbs
SHAFT SIZE	3/4"	3/4"	3/4"	3/4"	1"	1"
KEYWAY SIZE	3/16"	3/16"	3/16"	3/16"	1/4"	1/4"
SHAFT ID THREAD	5/16"-24 UNF 2B	5/16"-24 UNF 2B	5/16"-24 UNF 2B	5/16"-24 UNF 2B	3/8"-24 UNF 2B	3/8"-24 UNF 2B
ENGINE OIL REQUIRED	Synthetic 5W30	40F+:-30W, 30F:-5W30	40F+:-30W,30F:-5W30	Synthetic 10W30	Synthetic 10W30	Synthetic 5W30 suggested; see manual
ENGINE OIL CAPACITY	21 oz	20 oz	20 oz	28 oz	28 oz	32 oz
FUEL REQUIRED	87 (10% ethanol max)	87 (10% ethanol max)	87 (10% ethanol max)	87 (10% ethanol max)	87 (10% ethanol max)	87 (10% ethanol max)
FUEL TANK CAPACITY	1/2 gallon	1 gallon	.825 gallon	1 gallon	1 gallon	1 1/2 gallon
OIL ALERT	N	Y	Y	Y	Y	Y
ELECTRIC START	N	N	Y	Y	Y	Y
OVER HEAD VALVE	Y	Y	Y	Y	Y	Y

HONDA ENGINES						
BANJO PART NUMBER	E5H	E5HE	E6H	E8H	E11H	E13H
MANUFACTURER	HONDA	HONDA	HONDA	HONDA	HONDA	HONDA
MODEL NUMBER	GX160	GX160	GX200	GX240	GX340	GX390
RATED HP @ 3600 RPM	5.4 HP	5.4 HP	6.4 HP	8 HP	11 HP	13 HP
RATED TORQUE @ 2500 RPM	8 ft lbs	8 ft lbs	7.76 ft lbs	12.3 ft lbs	17.4 ft lbs	19.5 ft lbs
SHAFT SIZE	3/4"	3/4"	3/4"	1"	1"	1"
KEYWAY SIZE	3/16"	3/16"	3/16"	1/4"	1/4"	1/4"
SHAFT ID THREAD	5/16"-24 UNF 2B	5/16"-24 UNF 2B	5/16"-24 UNF 2B	3/8"-24 UNF 2B	3/8"-24 UNF 2B	3/8"-24 UNF 2B
ENGINE OIL REQUIRED	10W30	10W30	10W30	10W30	10W30	10W30
ENGINE OIL CAPACITY	.63 QT	.63 QT	.63 QT	1.16 QT	1.16 QT	1.16 QT
FUEL REQUIRED	86 (10% ETHANOL MAX)	86 (10% ETHANOL MAX)	86 (10% ETHANOL MAX)	86 (10% ETHANOL MAX)	86 (10% ETHANOL MAX)	86 (10% ETHANOL MAX)
FUEL TANK CAPACITY	.95 GALLON	.95 GALLON	.95 GALLON	1.59 GALLON	1.72 GALLON	1.72 GALLON
OIL ALERT	Y	Y	Y	Y	Y	Y
ELECTRIC START	N	Y	N	Y	Y	Y
OVER HEAD VALVE	Y	Y	Y	Y	Y	Y

HYDRAULIC MOTORS				
BANJO PART NUMBER	HY1012	HY1013	HY11131	HY11141B
US GALLONS / REVOLUTION	0.0038	0.0025	0.0030	0.0029
CUBIC INCHES / REVOLUTION	0.878	0.58	0.7	0.671
LITERS / REVOLUTION	0.0144	0.0097	0.0115	0.0110
MAX HYDRAULIC PRESSURE	3000 PSI	2000 PSI	1500 PSI	3045 PSI
MIN HYDRAULIC PRESSURE	600 PSI	200 PSI		10 PSIA
INLET PORT	SAE 12 (1 1/16-12 UN)	SAE 10 (7/8-14 UNF)	SAE 10 (7/8-14 UNF)	SAE 10 (7/8-14 UNF)
OUTLET PORT	SAE 16 (1 5/16-12 UN)	SAE 10 (7/8-14 UNF)	SAE 10 (7/8-14 UNF)	SAE 12 (1 1/16-12 UN)
MINIMUM GPM REQUIRED	9.1 GPM / 2400 RPM	6 GPM / 2400 RPM	7.3 GPM / 2400 RPM	7 GPM / 2400 RPM
MAXIMUM GPM REQUIRED	15.2 GPM / 4000 RPM	10 GPM / 4000 RPM	12.1 GPM / 4000 RPM	11.6 GPM / 4000 RPM
IDEAL GPM REQUIRED	13.7 GPM / 3600 RPM	9 GPM / 3600 RPM	10.9 GPM / 3600 RPM	10.5 GPM / 3600 RPM
INLET PORT	"A" PORT	"A" PORT	"A" PORT	PORTS NOT LABELED
OUTLET PORT	"B" PORT	"B" PORT	"B" PORT	PORTS NOT LABELED
DRAIN PORT	N/A	N/A	N/A	SAE 6 (9/16-18 UNF)
SHAFT SIZE	3/4"	9/16"	9/16"	5/8"

SPOOL VALVE INFO		
REQUIRED OUTLET FLOW	MIN 9 GPM / MAX 13 GPM	MIN 6 GPM / MAX 10 GPM
REQUIRED SYSTEM PRESSURE	MIN 600 PSI / MAX 3000 PSI	MIN 600 PSI / MAX 3000 PSI

# REFERENCE

PART NO	PAGE NO(S)	
12046	111, 143	0.5
12049	5, 107, 117	1.1
12052	111, 143	N/A
12099	107, 111, 113, 115, 119, 121, 123, 141, 143	0.07
12155	109, 117, 125, 127	1.19
12705	107, 109, 111, 113, 115, 117, 119, 121, 123, 125, 127, 141, 143, 153, 155	0.26
12709	109, 117, 125, 127, 153, 155	0.001
12710	107, 111, 113, 115, 119, 121, 123, 141, 143	0.01
12713	107, 111, 113, 115, 119, 121, 123	0.11
12716	107, 111, 115, 119, 121, 141	0.02
12717	107, 109, 111, 113, 115, 117, 119, 121, 123, 125, 127, 141, 143, 153, 155	0.001
12720	107, 109, 111, 113, 115, 117, 119, 121, 123, 125, 127, 131	0.03
12723	99	0.01
12724	99	0.001
12725	107, 109, 111, 113, 115, 117, 119, 121, 123, 125, 127, 131	0.002
12754	107, 109, 111, 113, 115, 117, 119, 121, 123, 125, 127	0.002
12756	111, 143	1.44
12766	109, 117, 127	0.08
12772	107, 109, 222, 113, 115, 117	0.21
12777	57, 95, 99, 107, 109, 111, 113, 117, 125, 127, 131, 133, 135, 137, 139, 145, 147, 149, 153, 155	0.018
12900	107, 109, 111, 113, 115, 117, 119, 121, 123, 125, 127	0.008
12901	107, 111, 113, 115, 119, 121, 123, 131, 141, 143, 153, 155, 165	0.004
13034	109, 117, 125, 127, 153	N/A
13055	125, 153, 155	0.674
13702	119, 121, 123, 125, 127	1.479
13712	119, 123, 125	4.018
13719	109, 117, 125, 127, 131, 153, 155	0.012
13765	119, 121, 151	0.05
13766	125, 153	0.084
13771	119, 121, 125, 127	0.204
13772	119, 121, 123, 125, 127	0.223
13777	59, 103, 119, 121, 123, 121, 141, 143, 145, 147, 149, 151, 153, 155, 157	0.025
13778	59, 103, 119, 121, 123, 131, 141, 143, 145, 147, 149, 151, 153, 155, 157	0.002
13999	119, 121, 123	0.266
15000	141, 143	2.244
15022	133, 135, 137, 139, 141, 143, 159, 161, 163	1.124
15025	151	N/A
15035	125	0.35
15702	141, 143	9.086
15703	141, 143	14.978
15712	141, 143	26.082
15751	111, 119, 121, 141, 143	0.014

PART NO	PAGE NO(S)	
15752	111, 141, 143	0.002
15772	141, 143, 153	1.75
15999	141, 143	0.282
16001	151	4.808
16003	151	5.688
16011	151	0.098
16019	151, 157	0.068
16099	151	0.25
16702	151, 157	11
16704	151	41.5
16706	151	0.888
16707	157	4
16710	151	0.002
16712	157	58
16713	151	0.2
16733	151	55
16751	151	0.024
16752	151	0.004
16765	151, 157	0.098
16773	151	3.452
16774	151	2.75
16775	157	4.242
16901	125, 127, 151, 153, 155, 157	0.01
16901SS	131	7.48
17000	133, 135, 137, 141	1.528
17001	133	1.472
17002	133, 135, 137	1.888
17003	133	1.926
17004	133	6.19
17005	133, 159	0.376
17006	133, 159	0.25
17007	133, 137, 139, 159, 163	0.216
17008	133, 137, 139	2
17010	133, 135, 137, 139, 141, 143, 149, 159, 161, 163	0.036
17011	133, 135, 137	0.866
17013	133, 135, 137, 141	0.034
17014	159, 161, 163	0.042
17016	133, 135, 137	0.214
17017	133, 135, 137	0.262
17018	133, 135, 137, 139, 159, 161, 163	0.01
17019	133, 135, 137, 139, 159, 161, 163	0.024
17023	133, 159	0.386

PART NO	PAGE NO(S)	
17024	133, 137, 139, 159, 163	0.128
17026	133, 137, 139	21.23
17028	133	0.16
17032	135	0.036
17033	133, 141	3.018
17035	133, 137, 139	0.18
17040	133, 159	0.028
17042	133, 137, 159, 161, 163	0.02
17046	133, 139	7.572
17049A	139	10.738
17049ASS	163	10.46
17056	139, 163	0.462
17100	133	4
17123	133, 135, 159	0.384
17130	133, 135, 137	0.022
17202	135	3.738
17208	135	1.802
17226	135	25.21
17235	135	0.35
17242	135	0.032
17406	137, 161	0.638
17408	137	2
17446	137	18
17701	111, 137, 143, 161	29.5
17704	111, 137, 143, 145, 147, 151, 161	0.046
18001	145, 147, 149	65.65
18004	145, 147, 149	1.628
18008	145, 147, 149	3.802
18009	145, 147, 149	0.036
18012	145, 147, 149	3.906
18013	145, 147, 149	0.53
18021	145, 147, 149, 165	0.012
18025	145, 147, 149	0.39
18026	145	9.91
18027	151, 157, 165	0.056
18029	131, 145, 149	0.63
18033	145, 147, 149, 151, 153, 155, 157, 165	1.236
18034	145, 147, 149, 151, 153, 155, 157, 165	0.048
18035	145, 165	2.73
18042	165	0.584
18044	165	0.056
18048	145	12.788

PART NO			PAGE NO(S)			PART NO			PAGE NO(S)			PART NO			PAGE NO(S)		
18049	145, 149	20.516	125A	81, 82	0.1	150A	81, 82	0.18									
18055	145, 149	0.834	125B	81, 82	0.3	150A90	85	0.307									
18056	149	0.1	125C	81, 82	0.29	150B	81, 82	0.57									
18100	145, 149	7.2	125D	81, 82	0.31	150C	81, 82	0.57									
18106	145, 147, 149	0.04	125E	81, 82	0.11	150C90	85	0.62									
18129	137, 145, 147, 161, 165	0.64	125F	81, 82	0.98	150CAP	81, 82	0.54									
18206	147	4.8	12600B	113, 123, 141	14	150D	81, 82	0.59									
18218	145, 147, 149	1.436	12702A	107, 109, 111, 113, 115, 117	1.21	150D90	85	0.65									
18435	157	1	12703A	107, 111, 113, 115, 119, 121, 123	2.37	150E	81, 82	0.21									
18500	145, 147, 149	13	12703AW	125	2.79	150F	81, 82	0.21									
18502	145, 147, 149, 153	0.802	12705V	107, 111, 125	0.24	150F90	85	0.267									
18504	145	1.928	12707W	109, 117, 127	2.79	150G	55, 78, 84	0.015									
18511	151	3.404	12709V	125	0.001	150GV	55, 78, 84	0.3									
18512	151	0.036	12710V	107, 111	0.01	150PL	81, 82	0.16									
18600	149	35.02	12712A	107, 109, 111, 113	3.25	150POICF5/8-4.1	132	47									
18700	105	1.728	12713V	107, 111, 141, 143	0.12	150RING	84	0.026									
18702	145, 147	1.794	12715A	107, 113, 115, 119, 121, 123, 141, 143, 153, 155	0.05	15999V	141, 143	0.288									
050C	81	0.14	12717V	107, 111, 125	0.01	16704A	151	41.5									
050D	81	0.16	12719A	107, 109, 111, 113, 115, 117, 119, 121, 123, 127, 141, 143, 153, 155	0.05	16774A	151	2.931									
050E	81	0.05	12719AV	107, 111	0.05	17000SS	159, 161, 163	1.58									
050F	81	0.06	12754V	107, 111, 125	0.01	17002SS	159, 161, 163	2.038									
075C	81, 82	0.15	12765A	107, 111, 113, 115, 119, 121, 123, 141, 143	0.05	17008-4.1	133	1.534									
075CAP	81, 82	0.13	12771A	107, 115	0.22	17008SS	159, 163	2									
075D	81, 82	0.15	12775A	107, 109, 111, 113, 115, 117, 119, 121, 123, 125, 131	0.01	17009B	133, 135, 137, 139, 159, 161, 163	0.022									
075E	81, 82	0.06	12777SS	159, 161, 163, 165	0.14	17011SS	159, 161, 163	0.888									
075F	81, 82	0.06	12882A	107, 119, 121, 133, 135, 141, 159	7.6	17026SS	159, 161, 163	32									
100125CAP	81, 82	0.27	12883B	133	0.146	17035SD	133	0.13									
100125PL	81, 82	0.06	12902A	107, 109, 111, 113, 115, 117, 119, 121, 123, 125, 127, 141, 143, 153, 155	0.006	17035SS	159, 163	0.18									
100A	81, 82	0.09	12999A	107, 111, 113, 115	0.25	17046SS	159	8.804									
100B	81, 82	0.29	12999AV	107, 111, 115	0.32	17055A	139, 163	1.75									
100C	81, 82	0.27	13719V	125	0.019	17056E	113, 123	2									
100D	81, 82	0.31	13777SS	165	0.205	17100SS	159	3.384									
100E	81, 82	0.1	13778V	165	0.002	17130SS	159, 161, 163	0.02									
100F	81, 82	0.11	150(200)K	84	0.134	17201A	135	8.736									
100G	81, 82	0.2	15000V	141, 143	2.364	17206A	135	0.628									
100GV	81, 82	0.02	150125A	81, 82	0.197	17408SS	161	2.106									
100RING	84	0.01	150125B	81, 82	0.26	17446SS	161	10.818									
12000A	107, 111, 113, 115, 119, 121, 123	0.75	150125C	81, 82	0.568	18001SS	165	57.5									
12000AV	107, 111, 115	0.9	150125D	81, 82	0.31	18004SS	165	1.616									
12055E	113, 123	0.57	150125E	81, 82	0.16	18010SS	113, 123, 139, 145, 147, 149, 163, 165	0.044									
12201W	125	1.46	150125F	81, 82	0.18	18023-1.125SS	145, 168	4.322									
12202W	109, 117, 125, 127	1.46	15035E	109, 117, 125, 127, 147, 153, 155	0.386	18023SS	145, 149, 165	4.32									

# REFERENCE

PART NO	PAGE NO(S)		PART NO	PAGE NO(S)		PART NO	PAGE NO(S)	
18025SD	145, 149	0.32	200P6PROE	106, 107	56.33	222PBI	140, 141	70
18025SS	161, 165	0.25	200P6PROV	106, 107	51	222PI6PRO	140, 141	100
18026SS	165	10.11	200PB	106, 107	15.786	222PIE5	140, 141	180
18055H	155	0.75	200PBI	132	48	222PIE51	140, 141	190
18100SS	165	7.5	200PB-SS	158, 159	52	222PIH5	140, 141	82
18106SS	165	0.04	200PH-5	106, 107	51	222PIH5E	140, 141	110
18200A	147	31.6	200PH-5E	106, 107	56.33	222PIH6	140, 141	110
18202A	147	4.918	200PH5-SS	158, 159	105	222POI	140, 141	60
18203A	147	4.92	200PH-5V	106, 107	48	231MPT	75	0.074
19001H	155	10.7	200PH5W	108	53	234PE5SS	160	168
19201W	153, 155	10	200PH6	106, 107	50.33	234PIE5	136, 137	160
19703W	153, 155	17.006	200PHA	112, 113	25	234PIE51	136	200
19772SS	153, 155	1.81	200PHY	112, 113	21.308	234POI	136	40.51
200150C	83	0.66	200PHYSS	162	52	234PPE5	110, 111	135
200A	83	0.3	200PHYW	112	28	234PPE51	110, 111	145.5
200A90	85	0.461	200PI-3	132	81	234PPE51V	110, 111	145
200B	83	0.64	200PI6PRO	132	81.5	234PPE5V	110, 111	123
200B90	85	0.948	200PIH-5	132	81.5	250CAP	81, 83	0.68
200C	83	0.69	200PIH5E	132	76.07	300A	81, 83	0.48
200C90	85	0.78	200PIHA	5	40.76	300B	81, 83	1.17
200CAP	75, 83	0.6	200PIHY	138	48	300C	81, 83	1.4
200CAPSH	75, 83	0.52	200PKL	84	0.02	300CAP	81, 83	1.07
200D	83	0.66	200PL	81, 83	0.21	300D	81, 83	1.19
200D90	85	0.88	200PO	106, 107	7.286	300E	81, 83	0.78
200E	83	0.32	200POI	132	52.5	300F	81, 83	0.57
200F	83	0.31	200POICF5/8	132	47	300F200F	84	0.609
200F45	85	0.346	200POICF7/8	132	47	300FF	84	0.644
200F90	85	0.434	200PO-SS	158, 159	47	300G	55, 78, 84	0.04
200FF	84	0.331	200POSSCF5/8	158	47	300GV	55, 78, 84	0.06
200G	55, 78, 84	0.02	200PO-V	106, 107	10	300K	84	0.23
200GV	55, 78, 84	0.03	200SBS	105	0.25	300P	84	0.036
200KL	84	0.18	201B	83	0.71	300P11PRO	118, 119	81
200P	84	0.17	201CAPSH	75	0.566	300P11PROW	124, 125	67
200P6PRO	106, 107	50	201FPT	75	0.04	300PB	118, 119	20
			201PBIW	134	58	300PBI	144	125
			201PIH5W	134	94	300PB-SS	164, 165	99
			201POIW	134	59	300PBW	124	26
			202CAP	75	0.34	300PH13SS	164, 165	150
			205PB	106, 107	16	300PH13W	124, 125	103
			205PB-V	106, 107	16	300PH-6	118, 119	50
			205POW	108	8.5	300PH6W	124, 125	56
			211FPT	75	0.03	300PHY	122, 123	26

PART NO			PAGE NO(S)			PART NO			PAGE NO(S)			PART NO			PAGE NO(S)																																																																																																																																																																																																																																																																																																																																																																										
300PHYSS	164, 165	140	75GV	55, 84	0.13	BF220BD	77, 166	1.5	300PHYW	122	N/A	75PL	81, 82	0.05	BF220GE	76, 77	0.154	300PIH13	144	176	A204	107, 109, 111, 113, 115, 117, 119, 121, 123, 125, 127, 141, 143, 153, 155	0.001	BF220GV	76, 77	0.08	300PIHY	148	140	A204V	107, 111, 125	0.002	BF300	76, 166	2.264	300PL	81, 83	0.43	AF100	80	0.304	BF300BD	77, 166	2.42	300PO	118, 119	12.005	AF100G	80	0.06	BF300GE	76, 77	0.2	300POI	144	106	AF100GV	80	0.06	BF300GFE	77	0.02	300POICF	144	N/A	AF150	80	0.43	BF300GFV	77	0.02	300POICF55	144	N/A	AF150G	80	0.08	BF300GV	76, 77	0.1	300PO-SS	164, 165	115	AF200	80	0.657	CAP038	88	0.03	300POW	124	15.3	AF200G	80	0.17	CAP050	88	0.06	300POW6	125, 125	N/A	AF200GV	80	0.17	CAP075	88	0.052	300SBS	105	0.25	AF300	80	1.175	CAP100	88	0.09	301PBIW	146	135	AF300G	80	0.17	CAP125	88	0.13	301PIH13W	146	181.37	AF300GV	80	0.17	CAP150	88	0.12	301POIW	146	130	AF400	80	1.587	CAP200	88	0.25	303B	81, 83	1.634	AF400G	80	0.45	CAP300	88	0.59	303B200A	83	1.554	AF400GV	80	0.45	CPLG025	87	0.03	303C	81, 83	1.74	AFB200	80	0.698	CPLG038	87	0.026	305PHAW	120	27.07	AFB300	80	1.42	CPLG050	87	0.09	333PBI	150, 151	185	BEM10-100	153	N/A	CPLG075	87	0.11	333PIE15	150, 151	242	BEM101-100	153	145	CPLG100	87	0.13	333PIH13	150, 151	285	BEM15	5	169	CPLG125	87	0.19	333POI	150, 151	90	BEM15-100	131	169	CPLG150	87	0.3	333POICF	150	190	BEM5	5	140	CPLG200	87	0.34	400A	81, 83	1.27	BEM5-182CZ	111, 143	95	CPLG300	87	0.836	400B	81, 83	2.03	BF075	76, 166	0.82	CR025	88	0.04	400C	81, 83	2.39	BF075BD	77	0.88	CR038	88	0.05	400CAP	81, 83	1.44	BF100	76, 166	0.82	CR050	88	0.13	400D	81, 83	2.07	BF100BD	77, 166	0.9	CR075	88	0.35	400E	81, 83	1.786	BF100GE	75, 77	0.07	CR100	88	0.27	400F	81, 83	1.42	BF100GRE	77	0.01	CR125	88	0.726	400G	84	0.06	BF100GRV	77	0.01	CR150	88	0.571	400PL	81, 83	1.11	BF150	76, 166	1.26	CR200	88	0.744	444PIH24	156	345	BF150BD	77, 166	1.32	CV050	19	0.27	444POI	156	120	BF200	76, 166	1.07	CV100	19	0.222	75A1/2	81	0.07	BF200BD	77, 166	1.2	CV100MT	19	0.17	75A1/4	81	0.08	BF200GE	76, 77	0.05	CV100V	19	0.217	75A3/4	81, 82	0.05	BF200GFV	75	0.05	CV10175	109, 117, 125, 127, 153, 155	0.2	75B1/2	81	0.14	BF200GV	76, 77	0.05	CV10175V	125	0.003	75B3/4	81, 82	0.14	BF200V	76, 166	1.07	CV221	19	1	75G	81	0.1	BF220	76, 166	1.45	CV300	19	1.45

# REFERENCE

PART NO			PAGE NO(S)			PART NO			PAGE NO(S)			PART NO			PAGE NO(S)																																																																																																																																																																																																																																																																																																																																																																										
CV301	19	1.518	DM200DCF	45	2.75	EL025-90	89	0.016	DF100A	70	0.183	DM200DE	63	3	EL038-90	89	0.04	DF100D	70	N/A	DM200DSS	68	6.9	EL050-90	89	0.07	DB20153M	62, 63	0.158	DM200DSST	68	6.9	EL075-90	89	0.1	DB20290	62, 63	0.004	DM200DT	636	2.75	EL100-45	89	0.14	DB20295	62, 63	0.002	DM200PL	62, 63	0.49	EL100-90	89	0.15	DM100ABSS	66	3.5	DM20153F	62, 63	0.251	EL125-90	89	0.22	DM100ASS	66	3.5	DM20153M	62, 63	0.417	EL150-90	89	0.33	DM100CAP	66	0.19	DM201SS	67, 68	1.158	EL200-90	89	0.434	DM100DBSS	66	3.75	DM20200A	62, 63	0.242	EL300-90	89	1.195	DM100DSS	66	3.75	DM20200D	62, 63	0.254	EVX071	21	3.82	DM100DSSE	66	3.75	DM20294A	62, 63, 67, 68	0.016	EVX100BL	24	4.313	DM100PL	66	0.234	DM20295A	63, 67, 68	0.01	EVX100SL	24	4.313	DM101SS	66	0.346	DM20296	62, 63, 67, 68	0.125	EVX101	21	3.892	DM10294A	66	0.01	DM202SSV	67, 68	1.32	EVX121	21	3.832	DM10295A	66	0.006	DM220A	64	4.3	EVX151	21	5.103	DM10296	66	0.1	DM220ABSS	69	0.43	EVX200BL	24	4.876	DM102SSV	66	0.386	DM220ASS	69	7.8	EVX200SL	24	4.876	DM150A	62	2.64	DM220CAP	64, 69	1	EVX201	22	4.312	DM150AB	62	2.2	DM220D	64	5.482	EVX220BL	24	6.253	DM150ABSS	67	6.3	DM220DBSS	69	7	EVX220SL	24	6.253	DM150AE	62	2.75	DM220DSS	69	9.8	EVX221	22	5.052	DM150ASS	67	6.35	DM221PL	58	0.3079	EVX300	23	9.24	DM150D	62	2.64	DM221SS	69	0.206	EVXR071	21	4.411	DM150DB	62	2.2	DM222SS	69	0.216	EVXR101	21	3.96	DM150DBSS	67	6.9	DM25153M	64	0.457	EVXR151	21	4.45	DM150DE	62	2.82	DM25200	64	0.106	EVXR201	22	5.33	DM150DSS	67	6.9	DM25294	69	0.0416	EVXR221	22	5.92	DM150DSSE	67	6.9	DM25294T	69	0.048	EVXR300	23	9.24	DM200A	63	3.007	DM300ACF	45	7.72	FC100	55	0.25	DM200AB	63	2.2	DM300AFP	65	4.8	FC200	55	0.23	DM200ABSS	68	5.768	DM300CAP	65	2.82	FC220	47, 55	0.25	DM200ACAP	67, 68	1	DM300DCF	45	8.4	FC220B	55	1.364	DM200ACF	45	3.15	DM300DFP	65	8.4	FC220TB	55	0.43	DM200AE	63	2.75	DM300PL	65	0.509	FC300	47, 55	0.34	DM200APL	67, 68	0.49	DM35153F	65	0.463	FC300B	55	1.76	DM200ASS	68	6.2	DM35153M	65	0.659	FC300TB	55	0.52	DM200AT	63	2.2	DM35200	65	1.23	GHFT075A	85	0.06	DM200CAP	62, 63	0.38	DMMT201A	63	2.5	GHFT075D	85	0.17	DM200D	63	2.75	DPCF100	71	0.5	GHFT075G	85	0.025	DM200DB	63	2.2	DPCM100	71	0.25	GHFT075MPT	85	0.04	DM200DBSS	68	6.9	DPCMT100	71	0.27	GHMT075B	85	0.14

PART NO			PAGE NO(S)			PART NO			PAGE NO(S)			PART NO			PAGE NO(S)																																																																																																																																																																																																																																																																																																																																																																										
GHMT075F	85	0.05	HB100/075-90	90	0.06	HBT050	91	0.03	GHMT075FPT	85	0.04	HB100/125-90	90	0.1	HBT050-038	91	0.02	GHMT075MPT	85	0.04	HB100-075	90	0.06	HBT050-075	91	0.03	GHN075	85	0.6	HB100-075SS	90	0.3	HBT075	91	0.05	H25053	8	0.265	HB100-125	90	0.08	HBT075-050	91	0.04	HB025	90	0.01	HB100-90	90	0.07	HBT075-050SS	91	0.246	HB025/038-90	90	0.01	HB100SS	90	0.3	HBT075-100	91	0.06	HB025/050-90	90	0.022	HB125	90	0.1	HBT100	91	0.08	HB025-038	90	0.012	HB125/100-90	90	0.09	HBT100-075	91	0.06	HB025-038SS	90	0.07	HB125/150-90	90	0.09	HBT100-100	91	0.08	HB025-050	90	0.015	HB125-075	90	0.08	HBT150-100	91	0.218	HB025-050SS	90	0.07	HB125-100	90	0.09	HBT150-150	91	0.235	HB025-90	90	0.01	HB125-150	90	0.1	HBT200	91	0.388	HB025SS	90	0.04	HB125-90	90	0.11	HBT300	91	1.161	HB038	90	0.01	HB125SS	90	0.5	HM038	91	0.03	HB038-025	90	0.02	HB150	90	0.13	HM050	91	0.01	HB038-050	90	0.02	HB150/125-90	90	0.16	HM075	91	0.026	HB038-050SS	90	0.1	HB150-100	90	0.09	HM100	91	0.04	HB038-90	90	0.02	HB150-125	90	0.1	HM125	91	0.07	HB038SS	90	0.09	HB150-200	90	0.19	HM150	91	0.08	HB050	90	0.03	HB150-90	90	0.23	HM200	91	0.22	HB050/038-90	90	0.024	HB150SS	90	0.68	HM300	91	0.763	HB050/075-90	90	0.04	HB200	90	0.2	HSV1000	112, 122, 138, 148, 154, 162	11	HB050-025	90	0.03	HB200/150-90	90	0.22	HV200	46	0.58	HB050-038	90	0.02	HB200-150	90	0.18	HY1001	149	1.5	HB050-058SS	90	0.128	HB200-90	90	0.33	HY1003	113, 123	1.5	HB050-075	90	0.03	HB200SS	90	1.13	HY1012	149, 155, 167	13.2	HB050-075SS	90	0.2	HB300	90	0.703	HY1013	113, 123, 163, 167	4.5	HB050-90	90	0.03	HB300-90	90	1.078	KZ-106-0031	30	N/A	HB050SS	90	0.13	HB300SS	90	3.55	KZ-10DY0-CF1	26	3.4862	HB075	90	0.04	HB400	90	1.64	KZ-11AA2-1CEBS-D01	30	N/A	HB075/050-90	90	0.04	HBB20012590	89	0.25	KZ-13AA2-1CEBS-D01	30	N/A	HB075/100-90	90	0.05	HBC050075	88	0.028	KZ-14AA2-1CEBS-D01	30	N/A	HB075-038	90	0.03	HBEL100-90	89	0.06	KZ-1AE9S-C01	26	2.2198	HB075-050	90	0.03	HBEL150/100-90	89	0.197	KZ-1CE7S-D0P	27	N/A	HB075-050SS	90	0.2	HBF075	90	0.06	KZ-1CE8S-D0P	27	N/A	HB075-058	90	0.038	HBF075-100	90	0.08	KZ-1CE9S-D01	26	N/A	HB075-100	90	0.05	HBF075-90	90	0.06	KZ-1CE9S-D0P	27	N/A	HB075-100SS	90	0.25	HBF100	90	0.09	KZ-203-0064	30	N/A	HB075-90	90	0.05	HB100-90	90	0.07	KZ-205-0161	30	N/A	HB075SS	90	0.2	HBT025	91	0.039	KZ-205-0181	30	N/A	HB100	90	0.06	HBT038	91	0.03	KZ-20DY0-CF1	26	3.522

# REFERENCE

PART NO	PAGE NO(S)		PART NO	PAGE NO(S)		PART NO	PAGE NO(S)	
KZ-20E7S-D01	26	N/A	KZ-89H22-10EYS-PF1	33	N/A	KZ-T2H22-10EYS-PF1	33	N/A
KZ-20E7S-D0P	27	N/A	KZ-95D33	27	N/A	L200B	84	0.64
KZ-20E8S-C01	26	2.2974	KZ-95D33-1CE9S-D0P	27	3.207	L200C	84	0.7
KZ-20E8S-D01	26	N/A	KZ-95E33	27	N/A	L200CAP	84	0.62
KZ-20E8S-D0P	27	N/A	KZ-95F33	27	N/A	L200D	84	0.736
KZ-20E9S-D0P	27	N/A	KZ-95F33-1CE9S-D0P	27	N/A	LEV038	29	0.55
KZ-211-0369	30	N/A	KZ-95H39	27	N/A	LEV038PL	29	0.08
KZ-211-0372	30	N/A	KZ-95I39	27	N/A	LEV050	29	0.6
KZ-21CA9-1CEFS-D01	31, 32	N/A	KZ-C2D37-ICEFS-D01	32	N/A	LS050-20	98	0.35
KZ-21CAA-20DJ0-POL	31	N/A	KZ-F2E33-1CE9S-D01	32	N/A	LS050-40	98	0.35
KZ-22CA9-1CEFS-D01	31	N/A	KZ-F2F33-1CE9S-D01	32	N/A	LS050-80	98	0.37
KZ-23CA9-1CEFS-D01	31	N/A	KZ-F2H22-10EYS-PF1	32	N/A	LS050B/C1	99	0.298
KZ-25CA9-1CEFS-D01	31	N/A	KZ-F4F33-1CE9S-D0V	32	N/A	LS075-20	98	0.3
KZ-398-0276	28, 29	0.0762	KZ-G2D37-ICEFS-D01	32	N/A	LS075-40	98	0.33
KZ-398-0758	28	N/A	KZ-H2D37-ICEFS-D01	32	N/A	LS075-80	98	0.35
KZ-511-0012	29, 30, 31	0.049	KZ-H7D37-ICEFS-D01	32	N/A	LS075B/C1	99	0.28
KZ-511-0013	29, 30, 31	0.052	KZ-K0HU0-CF1	26	3.6378	LS075-G	99	0.004
KZ-511-0014	29, 30, 31	0.0596	KZ-KR15KIT	26	0.06076	LS100-20	98	0.91
KZ-511-0015	29, 30, 31	0.0644	KZ-KRKIT	26	0.8398	LS100-40	98	0.9
KZ-511-0019	29, 30, 31	0.07	KZ-KZ1733-1CEBS-D01	32	N/A	LS100-80	98	0.96
KZ-511-0026	29, 30, 31	0.051	KZ-KZ1754-1CEBS-D01	32	N/A	LS100B/C1	99	0.872
KZ-511-0027	29, 30, 31	0.053	KZ-LOE7S-D0P	27	N/A	LS100-C1	99	0.232
KZ-511-0028	29, 30, 31	0.0642	KZ-M4K22-10DW0-PFV	33	N/A	LS100-G	99	0.02
KZ-511-0154	28	0.069	KZ-NA4C28-1CEBS-D0V	28	N/A	LS100-GV	99	0.02
KZ-511-0156	28	0.0528	KZ-NAZC28-1CEBS-D01	28, 29	0.337	LS120	57, 99	0.07
KZ-511-0167	30	N/A	KZ-NAZC28-1CEBS-R01	28	N/A	LS125-20	98	0.86
KZ-511-0168	30	N/A	KZ-NMZB28-1CEBS-D01	28	N/A	LS125-40	98	0.84
KZ-511-0170	30	N/A	KZ-NMZB28-1CEBS-R01	28	N/A	LS125-80	98	0.9
KZ-511-0171	30	N/A	KZ-NPZC28-1CEBS-D01	28, 29	0.3416	LS125B/C1	99	0.826
KZ-67D33-1AE9S-C01	26	N/A	KZ-NPZC28-1CEBS-R01	28	N/A	LS140	57, 99	0.07
KZ-67D33-1CE9S-D01	26	N/A	KZ-NQZC28-1CEBS-D01	28	0.3338	LS150-06	100	2.42
KZ-67G22-10DY0-CF1	26	6.696	KZ-NQZC28-1CEBS-R01	28	N/A	LS150-12	100	2.42
KZ-67G22-20DY0-CF1	26	6.9635	KZ-S2B28-1CEBS-D01	26, 32	N/A	LS150-120	100	2.5
KZ-67G22-K0HU0-CF1	26	7.1	KZ-S2C28-1CEBS-D01	32	N/A	LS150-20	100	2.42
KZ-67H22-10DY0-CF1	26	7.9435	KZ-S2F33-1CE9S-D01	32	N/A	LS150-30	100	2.5
KZ-67H22-20DY0-CF1	26	7.9975	KZ-S4F22-90EYS-DFV	32	N/A	LS150-50	100	2.5
KZ-67H22-K0HU0-CF1	26	8.18	KZ-S4H22-90EYS-DFV	32	N/A	LS150-80	100	2.5
KZ-84B23-1CE9S-D01	33	N/A	KZ-S8C28-1CEBS-D01	26	N/A	LS150B/C	101	1.91
KZ-84D23-1CE9S-D01	33	N/A	KZ-S8F22-K0HU0-CF1	26	6.631	LS150-C	57, 101	0.576
KZ-88D33-1CE9S-D01	33	N/A	KZ-S8F33-1AE9S-C01	26	4.5905	LS150-G	57, 101	0.03
KZ-88H22-10EYS-PF1	33	N/A	KZ-S8F33-1CE9S-D01	26	4.453	LS150-GV	57, 101	0.03
KZ-89D33-1CE9S-D01	33	N/A	KZ-S8F33-20E8S-C01	26	4.587	LS180	57, 99	2.12

PART NO			PAGE NO(S)			PART NO			PAGE NO(S)			PART NO			PAGE NO(S)																																																																																																																																																																																																																																																																																																																																																																										
LS200-06	100	2.5	LSQ200-PL	56, 57, 59, 95, 97, 101	0.042	LST150	57, 95	0.07	LS200-100	100	2	LSQ200-R	56, 57, 59, 95	0.002	LST150-100	94	1.9	LS200-12	100	2.33	LSQ200R1	97	0.002	LST150-30	94	2.12	LS200-120	100	2	LSQ200-RV	97, 101	0.004	LST150-50	94	2.15	LS200-20	100	2.33	LSS300-BC	102, 103	23.88	LST150-80	94	2.13	LS200-30	100	2.42	LSS300-C	102, 103	2.91	LST150-B	57, 95	0.22	LS200-50	100	2.42	LSS300-G	102, 103	0.1	LST150-G	57, 95	0.014	LS200-80	100	2.42	LSS300-GV	102, 103	0.044	LST150-GV	57, 95	0.024	LS200B/C	101	2	LSS300-H	103	1.724	LST150-HB	95	1.794	LS206	57, 97, 101	0.3	LSS300-S	102, 103	0.032	LST15100	57, 95	0.27	LS2100	101	0.09	LSS300-SV	102, 103	0.05	LST1516	57, 95	0.196	LS212	57, 97, 101	0.29	LSS306	103	0.198	LST1530	57, 95	0.17	LS2120	57, 97, 101	0.08	LSS308	103	0.256	LST1550	57, 95	0.15	LS220	57, 97, 101	0.2	LSS312	103	0.37	LST1580	57, 95	0.1	LS230	57, 97, 101	0.188	LSS320	103	0.4	LST180	57, 95	0.07	LS250	57, 97, 101	0.13	LSS330	103	0.368	LST200-10SS	96	16	LS250P	101	0.116	LSS350	103	0.366	LST200-50SS	96	16	LS280	57, 97, 101	0.1	LST075-100	94	0.83	LST200-B	97	1.946	LS300EC	59, 103	0.626	LST075-16	94	0.824	LST200-GV	97	0.04	LS304	59, 103	0.598	LST075-30	94	0.84	LST200-HSS	97	1.614	LS308	59, 103	1.106	LST075-50	94	0.84	LST204SS	59, 97	0.416	LS312	59, 103	4.31	LST075-80	94	0.83	LST206SS	59, 97	0.382	LS320	59, 103	1.03	LST075-H	95	0.516	LST208SS	59, 97	0.326	LS350	59, 103	0.92	LST075-HB	95	0.738	LST2100SS	59	0.45	LS720	99	0.04	LST100-100	94	0.76	LST210SS	59, 97	0.48	LS740	99	0.04	LST100-16	94	0.78	LST216SS	59, 97	0.27	LS780	99	0.04	LST100-30	94	0.79	LST220SS	97	N/A	LSM300-04	102	8	LST100-50	94	0.81	LST230SS	59, 97	0.49	LSM300-08	1021	8	LST100-80	94	0.78	LST250SS	59, 97	0.49	LSM300-12	102	8	LST100-B	57, 95	2.17	LST280SS	59, 97	0.48	LSM300-20	102	8	LST100-G	57, 95	0.02	LST5100	93	0.016	LSM300-50	102	8	LST100-GV	57, 95	0.02	LST530	93	0.05	LSQ150-B/C	96, 97	3.8	LST100-H	95	0.472	LST550	93	0.024	LSQ200-06	96	4.17	LST100-HB	95	2.25	LST580	93	0.02	LSQ200-20	96	4.17	LST1100	57, 95	0.07	LSTM050-30	92	0.76	LSQ200-30	96	4.17	LST116	57, 95	0.084	LSTM050-30C	92	0.324	LSQ200-50	96	4.17	LST125-16	94	2.032	LSTM050-50	92	0.3	LSQ200-80	96	4.17	LST125-30	94	2.22	LSTM050-50C	92	0.76	LSQ200-B/C	97	3.63	LST125-50	94	2.24	LSTM050-80	92	0.76	LSQ200-C	97	1.74	LST125-80	94	2.18	LSTM050-80C	92	0.316	LSQ200-G	97	0.05	LST125-HB	95	1.846	LSTM050B	93	0.103	LSQ200-GV	97	0.162	LST130	57, 95	0.07	LSTM050BC	93	0.12



PART NO			PAGE NO(S)			PART NO			PAGE NO(S)			PART NO			PAGE NO(S)		
M220125BRB	54	0.16	M220SWPG90	49	N/A	M300P11PRO	120, 121	61.988									
M220150BRB	54	0.16	M220TEE	51	0.522	M300PB	120, 121	21.35									
M220150BRB90	54	0.211	M220Y45	47, 51	1.316	M300PH6	120, 121	45.4									
M220150HBT	54	0.275	M220YG45	6, 47, 51	1.34	M300PH6W	126	49									
M220150MPTSS	52	0.65	M221CPG	6, 50	N/A	M300PLG	53	0.25									
M220200CPG	51	0.2	M221CPG6	6, 50	N/A	M300PLG075	6, 53	0.23									
M220200HBT	54	0.39	M221G	47, 55	0.03	M300PLG100	6, 53	0.248									
M220200SWP90	49	0.356	M221GSA	50	0.258	M300PO	120, 121	9.792									
M220200TEE	51	0.567	M221SWP90	6, 43	N/A	M300POW6	126	16.24									
M220375SWFSS	50	1.35	M222G	55	0.03	M300SWFSS	50	1.46									
M220A	53, 83	0.2	M300200CPG	51	0.267	M300SWP050G90	6	0.699									
M220ASWP90	49	0.399	M300220BRB	54	0.284	M300SWP90	49	0.675									
M220BRB	54	0.19	M300220BRB90	54	0.406	M300SWPG90	6, 49	0.75									
M220BRB45	54	0.225	M300220CPG	47, 51	0.245	M300TEE	51	1.111									
M220BRB90	54	0.309	M300220MPTSS	52	1.332	M300Y45	47, 51	3.32									
M220BRBSWP90	49	0.399	M300220SWP90	49	0.571	M300YG45	6, 47, 51	3.258									
M220BWASS	52	0.5	M300220WYCG	51	1.050	M301CPG7	6, 50	N/A									
M220CPG	50	0.21	M300300HBT	54	1.034	M301G	47, 55	0.03									
M220CPG2GISO	6, 50	0.15	M300375SWFSS	50	3.2	M301GSA	50	0.55									
M220CPG3G	6, 50	N/A	M300400A	53, 130	0.712	M302G	55	0.05									
M220CPG45	47, 50	0.24	M300400BRB	54, 130	0.728	M303D	53	1.5									
M220CPG6	47, 50	0.375	M300A	53	0.35	M305PHYW	126	26.4									
M220CPG6025G	6, 50	N/A	M300ASWP90	49	0.897	M332PIE101W	152	270									
M220CPG90	61	0.341	M300BRB	54	0.478	M332PIE10W	152	N/A									
M220CR	53	0.578	M300BRB45	54	0.518	M332PIH13W	152	155									
M220D	53, 83	0.73	M300BRB90	54	0.798	M332PIHAW	154	68.592									
M220FPT	52	0.26	M300BRBSWP90	49	1.184	M332PIHYW	154	190									
M220MPT	52	0.21	M300BRBSWP90	6, 49	1.24	M332POIW	152	70.532									
M220MPTSS	52	0.62	M300CPG	50	0.417	M350PBW	130	34.1									
M220MPTSWP90	49	0.331	M300CPG12	6, 48	1.01	M350PE15W	129	131.3									
M220P6PRO	114, 115	N/A	M300CPG12G	6, 50	N/A	M350PEOW	129	17.1									
M220PH5	114, 115	55	M300CPG2GISO	6, 50	0.279	M350PH13W	129	88.2									
M220PH5W	116	55	M300CPG45	47, 50	0.518	M350PHAW	130	33.5									
M220PH6	114, 115	55	M300CPG55G	6, 50	0.538	M350PHYW	129	40.9									
M220PLG	53	0.12	M300CPG7	47, 50	0.632	M350POW	129	17.1									
M220PLG038	6, 53	0.1	M300CPG7025G	6, 50	N/A	M350PVAN14W	129	102									
M220PLG075	6, 53	0.11	M300CPG90	51	0.745	MBF100	60, 166	0.9									
M220PO	112, 113	8.372	M300CR	53	1.215	MBF100BD	60, 166	0.948									
M220SWFSS	50	0.58	M300FPT	52	0.514	MBF200	60, 166	1.37									
M220SWP038G90	6	N/A	M300MPT	52	0.437	MBF200BD	60, 166	1.44									
M220SWP050G90	6	0.292	M300MPTSS	52	1.85	MBF220	60, 166	1.62									
M220SWP90	49	0.286	M300MPTSWP90	49	0.833	MBF220BD	60, 166	1.62									

# REFERENCE

PART NO			PAGE NO(S)			PART NO			PAGE NO(S)			PART NO			PAGE NO(S)																																																																																																																																																																																																																																																																																																																																																																										
MBF300	60, 166	2.34	MLEV100	29, 39	0.65	MLST100-H	57	0.467	MBF300BD	60, 166	2.5	MLS100-80	56	0.88	MLST100-HB	57	0.63	MBP200	73	0.26	MLS100B	57	0.646	MLST150-100	56	2	MCV100	50	0.154	MLS100BC	57	0.896	MLST150-30	56	2	MCV100V	50	0.153	MLS200-06	52	2.25	MLST150-50	56	2	MCV200	50	0.45	MLS200-12	56	2.5	MLST150-80	56	2	MCV221	50	0.5	MLS200-20	56	2.15	MLST150-80V	56	2.125	MCV300	50	1.224	MLS200-30	52	2.15	MLST150-H	57	1.292	MCV301	50	1.26	MLS200-50	56	3.9	MLST150-HB	57	1.75	MEVX100	35	3.82	MLS200-80	56	2.15	MLSTM100-80	55	0.34	MEVX100BL	38	4.7	MLS200B	57	1.526	MLSTM100HB	55	0.34	MEVX100SL	38	4.7	MLS200BC	57	2.07	MLSTM100HBC	55	0.34	MEVX101	35	4.24	MLS200BCM	56	2.315	MPRV100-050	45	1.506	MEVX1012	39	9.6	MLS2100SS	59	0.54	MPRV100-075	45	1.45	MEVX1013	39	14.548	MLS220C1	59	0.82	MPRV100-100	45	1.5	MEVX1014	39	19.485	MLS220G1	59	0.008	MPRV100-125	45	1.54	MEVX102	39	9.073	MLS220R1	59	0.417	MSUV100FP	18	0.46	MEVX103	39	14.47	MLS222-04	58	3.82	MSW220	50	0.4	MEVX200	36	4.22	MLS222-10	58	3.5	MTF100BD	60	0.42	MEVX200BL	38	5.751	MLS222-16	58	3.7	MTF220BD	60	0.75	MEVX200SL	38	7.018	MLS222-30	58	3.75	MTF300BD	60	2.092	MEVX201	36	4.775	MLS222-50	58	3.75	MV100BL	12, 44	1.2	MEVX220BL	38	6.98	MLS222-80	58	3.7	MV100CF	12, 40	0.75	MEVX220SL	38	N/A	MLS222B	59	2.2	MV100SL	44	1.13	MEVX221	36	4.775	MLS222BC	59	3.25	MV200BL	12,44	2	MEVX300	37	8.98	MLS250SS	59	0.6	MV200CF	40	2.024	MEVX300BL	38	18.28	MLS280SS	59	0.57	MV200SL	44	2	MEVXR100	35	2.491	MLS300-12	58	8	MV220BL	12, 44	4.63	MEVXR100SL	38	4.7	MLS300-20	58	8	MV220CF	40	2.798	MEVXR101	35	3.82	MLS300-20V	58	N/A	MV220SL	44	2.75	MEVXR200	36	2.882	MLS300-50	58	8.44	MV225CF	40	7.3	MEVXR200SL	38	3.979	MLS300B	59	5.01	MV300	40	3.9	MEVXR220	36	3.405	MLS300B1	103	5.357	MV300BL	44	6.68	MEVXR220SL	38	6.627	MLS300BC	59	7.48	MV300CF	40	5.866	MEVXR300	37	8.98	MLS300CAP	59, 103	1.36	MV301CF	47	6	MFM100	48	2.75	MLS300ECG	59, 103	0.024	MVS220CF	41, 47	1.744	MFM220	48	2.75	MLS300ECGV	59, 103	0.04	MVS220FP	41	1.804	MFM300	47	5.4	MLS300G	59, 103	0.03	MVS300CF	42	3.046	MHV200	46	0.57	MLST100-100	56	0.75	MVS300CFFP	42	3.75	MHV220A	46, 47	0.8	MLST100-30	56	0.75	MVS300HSFP	43	6.32	MIS220	47	10.175	MLST100-50	56	0.75	MVSF220FP	41	1.78	MIS300	47	23.06	MLST100-80	56	0.75	MVSF300	42	3.29

PART NO			PAGE NO(S)			PART NO			PAGE NO(S)			PART NO			PAGE NO(S)		
MVSF300FP	42	4	PV100-075V	19	0.35	RN150-125	87	0.14									
MVSMT220FP	41	1.75	PV10265	19	0.07	RN200-125	87	0.16									
MVSMT300	42	3.192	PV10265V	19	0.2	RN200-150	87	0.17									
MVSMT300HSFP	43	6.44	RB038-025	87	0.01	RN300-200	87	0.365									
NIP025-SH	87	0.01	RB050-018	87	0.02	RS21	91	0.756									
NIP038-SH	87	0.02	RB050-025	87	0.02	RSTB	91	0.704									
NIP050-3	87	0.04	RB050-038	87	0.01	SL025-90	89	0.02									
NIP050-SH	87	0.02	RB075-025	87	0.04	SL038-90	89	0.03									
NIP075-4	87	0.074	RB075-038	87	0.03	SL050-90	89	0.06									
NIP075-6	87	0.12	RB075-050	87	0.03	SL075-45	89	0.07									
NIP075-SH	87	0.03	RB100-018	87	0.60	SL075-90	89	0.08									
NIP100-4	87	0.09	RB100-025	87	0.07	SL100-45	89	0.1									
NIP100-6	87	0.14	RB100-050	87	0.05	SL100-90	89	0.13									
NIP100-SH	87	0.038	RB100-075	87	0.04	SL125-45	89	0.14									
NIP125-4	87	0.136	RB125-038	87	0.1	SL125-90	89	0.14									
NIP125-6	87	0.22	RB125-075	87	0.09	SL150-45	89	0.22									
NIP125-SH	87	0.06	RB125-100	87	0.06	SL150-90	89	0.25									
NIP150-3	87	0.14	RB150-075	87	0.12	SL200-45	89	0.34									
NIP150-4	87	0.22	RB150-100	87	0.1	SL200-90	89	0.41									
NIP150-5	87	0.26	RB150-125	87	0.1	SL300-45	89	0.833									
NIP150-6	87	0.34	RB200-075	87	0.18	SL300-90	89	1.054									
NIP150-SH	87	0.12	RB200-100	85	0.17	ST200	74	0.809									
NIP200-4	87	0.25	RB200-125	87	0.14	ST300	74	1.332									
NIP200-6	87	0.38	RB200-150	87	0.12	SUV050FP	18	0.25									
NIP200-SH	87	0.14	RB300-150	87	0.415	SUV075FP	18	0.4									
NIP2101	73	0.3	RB300-200	87	0.359	SUV100FP	18	0.4									
NIP300-4	87	0.434	RB400-300	87	1.032	SUV125FP	18	0.88									
NIP300-6	87	0.696	RC100-075	87	0.15	SUV150FP	18	0.88									
NIP300-SH	87	0.307	RC150-100	87	0.2	SUV200FP	18	1.45									
NIP400-SH	87	1.558	RC150-125	87	0.206	SW100	91	0.16									
PLUG025	88	0.03	RC200-050	87	0.28	SW150	91	0.36									
PLUG038	88	0.02	RC200-100	87	0.26	SW220	91	0.52									
PLUG050	88	0.02	RC200-125	87	0.26	TA283	75	0.2									
PLUG075	47, 88	0.04	RC200-150	87	0.26	TA283QD	75	0.3									
PLUG100	88	0.06	RC300-200	87	0.624	TC120	86	0.1									
PLUG125	88	0.09	RN050-038	87	0.018	TC130	86	0.1									
PLUG150	88	0.1	RN075-050	87	0.03	TC150	86	0.11									
PLUG200	88	0.152	RN100-050	87	0.06	TC162	86	0.12									
PLUG300	88	0.445	RN100-075	87	0.06	TC181	86	0.14									
PV075	19	0.53	RN125-075	87	0.086	TC193	86	0.12									
PV100	19	0.52	RN125-100	87	0.08	TC206	86	0.14									
PV100-075	19	0.64	RN150-100	87	0.122	TC218	86	0.13									

# REFERENCE

PART NO	PAGE NO(S)		PART NO	PAGE NO(S)	WEIGHT
TC224	86	0.14	VSF200	13	1.25
TC231	86	0.15	VSF200CF	35	1.49
TC250	86	0.16	VSF200FPAF	11	3.05
TC287	86	0.17	VSF204FP	14	1.82
TC312	86	0.16	VSF300	15	3.424
TC331	86	0.17	VSFHB200	13	1.52
TC343	86	0.17	VSFMT200	13	1.562
TC425	86	0.18	VSFMT204FP	14	1.862
TC438	86	0.36	VSFMT204HSFP	14	2.95
TC456	86	0.38	VSFMT300	15	3.374
TEE025	88	0.02	VSFMT300FP	15	4.29
TEE038	88	0.05	VSFMT300HSFP	15	6.63
TEE050	88	0.1	VSMT200	13	1.35
TEE075	88	0.14	VSMT200CF	35	1.432
TEE100	88	0.21	VSMT204FP	14	1.874
TEE125	88	0.32	VSMT300	15	3.27
TEE150	89	0.445	VSS025	19	0.634
TEE200	89	0.584	VSS038	19	0.59
TEE300	89	1.594	VSS050	19	0.7
TEG075	88	0.14	VSS075	19	1.298
TEG100	88	0.22	VSS100	19	2.094
TF038SS	78	0.25	VSS150	19	3.996
TF050	78	0.25	VSS200	19	6.808
TF050SS	78	0.8	VSS300	19	18.43
TF075	78	0.2	W230237	72	1.07
TF075SS	78	1.15	W230238	72	1.17
TF075V	78	0.22	W230239	72	1.07
TF100	78	0.35	W230240	72	1.1
TF100AV	79	0.44	WSF210FSA	72	1.2
TF100G	78	0.02	WSF210FSAV	72	1
TF100GV	78	0.035	WSMT210FSA	72	1.07
TF100SS	78	2.85	WSMT210FSAV	72	1
TF125	78	0.35			
TF125AV	79	0.386			
TF125SS	78	1.92			
TF138GV	78	0.1			
TF150	78	0.63			
TF150AV	79	0.68			
TF150SS	78	4.88			
TF200	78	0.55			
TF200AV	79	0.596			
TF200SS	78	3.6			
TF200V	78	0.56			

